



UNIVERSITY OF THESSALY
DEPARTMENT OF LIFE SCIENCES
FACULTY FOR BIOCHEMISTRY AND
BIOTECHNOLOGY

**«Construction of targeting vectors for Cre/lox
assisted genome modifications»**

DIPLOMA PROJECT
OF
UNDERGRADUATE STUDENT

Vachaviolos Ioannis-Angelos

Supervisors: Feil Robert
Mathiopoulos Konstantinos
Sarafidou Theologia

Tübingen, 2010

ABSTRACT

The extensive research interest in signaling through cGMP reveals an increasing number of cellular functions that are modulated by this molecule. cGMP signaling is involved in diverse processes such as vascular smooth muscle relaxation, prevention of platelet aggregation, angiogenesis, atherosclerosis learning and memory and perhaps many other (patho-) physiological functions that we do not know yet. Many commonly used medications are designed to target cGMP. For example, NO derived from the sublingual nitroglycerin pills increases the concentration of intracellular cGMP by activating the NO-GC (guanylyl cyclase activated by NO). The increase in cGMP causes dilation of blood vessels of the heart, facilitating cardiac oxygenation of people with coronary heart disease (angina pectoris). Transgenic mouse models have greatly contributed to dissect the in vivo functions of cGMP as well as other physiological processes and complex diseases. The present work describes the construction of a targeting vector to modify the murine Rosa26 locus by homologous recombination in embryonic stem cells. The construct was based on a published targeting vector that allows Cre/lox-induced switching between the expression of a membrane-targeted red fluorescent protein (mT) and a membrane-targeted green fluorescent protein (mG) from the Rosa26 locus (pR26mT/mG “A *global double-fluorescent Cre reporter mouse*”, Muzumdar *et al.*, 2007). The aim was to replace the mG fragment in pR26mT/mG by a multiple cloning site (MCS), where we could subsequently sub-clone any gene/sequence of interest. The expression cassette is driven by the strong CAG promoter. It encodes a membrane-targeted red fluorescent protein variant (tandem dimer Tomato, tdTomato or mT) surrounded by loxP sites, followed by the MCS for unique enzymes. In the MCS we inserted a fluorescence resonance energy transfer (FRET)-based cGMP indicator, cGi500 in order to monitor in real time the cGMP levels in live cells/tissues (pR26mT/cGi500). Alternatively an improved version of the herpes simplex virus thymidine kinase (sr39tk) was inserted into the MCS. This reporter enzyme can be used for non-invasive cell tracking in mice. Finally to show that the constructs were functional, we transfected mouse embryonic fibroblasts with the above constructs (pR26mT/cGi500, pR26mT/mG) in the presence and absence of Cre recombinase. Indeed the experiment showed proper Cre-activatable expression of the constructs. The newly generated targeting vectors will now be used to produce gene-targeted mice for visualization of cGMP (cGi500 cGMP sensor) as well as for cell tracking (sr39tk reporter).

Key words: cGMP, cGi-500, Cre/lox, targeting vector, sr39tk, transgenic mouse models, mT/mG, Cre-mediated recombination

INDEX

Abstract.....	1
Index.....	2
A. Introduction	
A.1 cGMP Signaling.....	4
A.2 Site Specific Recombination.....	11
A.3 The cGi-500 sensor.....	16
A.4 The Rosa26mT/mG plasmid.....	19
A.5 Aim of this work and Strategy.....	21
B. Materials and Methods	
B.1 Materials.....	22
B.2 Molecular Biology Methods... ..	27
B.3 Cell Culture Methods.....	35
B.4 Microscopy.....	37
C. Results	
Overall view of the project strategy.....	38
C.1 Initial Materials.....	40
C.2 Construction of the pmT/mG plasmid	40
C.3 Construction of the pUC-loxP-EGFP-pA plasmid.....	43
C.4 Construction of the pUC-loxP-MCS-pA plasmid.....	46
C.5 Construction of the pLinker5 plasmid.....	49
C.6 Subcloning of CMV-cGi500 into pLinker5 (pL5-cGi500).....	51
C.7 Subcloning of CMV-sr39tk into pLinker5 (pL5-sr39tk).....	54
C.8 Construction of pmT/MCS plasmid	57
C.9 Subcloning of pL5-cGi500 into pmT/MCS (pmT/cGi500).....	60
C.10 Subcloning of pL5-sr39tk into pmT/MCS (pmT/sr39tk).....	63
C.11 Construction of pR26mT/MCS (targeting vector).....	66
C.12 Construction of pR26mT/cGi500 (targeting vector).....	69
C.13 Cell Culture Results.....	71
D. Discussion.....	
D. Discussion.....	80
E. Appendix	

I. Project Strategy.....	82
II. Plasmid Cards.....	83
III. Cell Culture Plan.....	95
IV. Abbreviations.....	96
REFERENCES.....	97

A. Introduction

A.1 cGMP Signaling

The cGMP (cyclic guanosine monophosphate) is a molecule that signals the start of many cellular functions that are involved in disease and health conditions. Many ligands (hormones, neurotransmitters, toxins) cause cell response through cGMP. The biochemical mechanisms that are involved in this response include the composition, function and finally the degradation of cGMP.

A.1.1 Composition of cGMP- Guanylyl Cyclases

Guanylyl cyclases (GC) is a family of enzymes that are expressed in almost all cells and catalyze the conversion of GTP → cGMP. They are divided into two categories: those that are bound to the membrane (particulate GC, pGC) and the soluble ones (soluble GC, sGC).

A.1.1.1 GCs located on the membrane (particulate GCs)

Seven isomers of the mammalian pGCs have been identified so far (GC-A,-B,-C,-D,-E,-F,-G).The pGCs based on their receptor specificity have been categorized into three groups: natriuretic peptide receptors, intestinal peptide receptors and orphan receptors. The GC-A,-B are activated by natriuretic peptides (ANP: atrial natriuretic peptide, BNP: brain natriuretic peptide, CNP: C-type natriuretic peptide. The GC-C was originally identified as the receptor of enterotoxins, but it can be also activated by endogenous mammalian peptides, such as guanylin, uroguanylin and lempoguanilin. The GC-D is expressed in the olfactory epithelium and it appears to be involved in the recognition of pheromones. It is believed to act as an olfactory receptor. The GC-E,-F are expressed in the retina. Their ligands are yet unknown. The GC-G is expressed in the lungs and skeletal muscles, its ligands are unknown today [2].

A.1.1.1.1 GC- receptors of natriuretic peptides

The ANP (atrial natriuretic peptide) induces natriuresis, diuresis and hypotension and inhibits secretion of rennin and aldosterone. It also seems to be involved in electrolyte/ liquids balance. The BNP is a peptide isolated from the brain and it is also found in the heart and blood. The CNP also affects natriuresis and diuresis and the relaxation of smooth muscles of blood vessels but it is less active than ANP and BNP. The mechanism by which natriuretic peptides affect physiological functions includes the activation of GC-coupled receptors and the accumulation of cGMP in the cytoplasm [2].

A.1.1.1.2 GC- intestinal peptide receptors

The GC-C is mainly expressed in intestinal cells, but also in kidneys, testis, placenta and liver. It functions as a receptor for peptide hormones of guanylin family. The first

ligand that was identified was the enterotoxin somatostatin (STa) produced by *E.coli* bacteria, which activates the GC and increases cGMP in intestinal cells. The activation of GC-C by STa results in severe diarrhea in humans [2].

A.1.1.1.3 GC-orphan receptors

The pGCs for which no ligands have been identified yet are classified as orphan receptors. Experiments have shown that ligands that activate other GCs do not activate GC-D,-E,-F,-G [2].

A.1.1.1.4 Structure of pGCs

The pGCs consist of the following regions:

- Extracellular ligand binding domain to the NH₂ terminus
- Transmembrane domain
- Cytoplasmic region near the membrane
- Kinase homology domain
- Hinge region
- A carboxyl-terminal, catalytic domain
- A carboxyl-terminal tail expressed in cells of intestine mucosa and in sensory organs (GC-C, GC-D,-E,-F) [2].

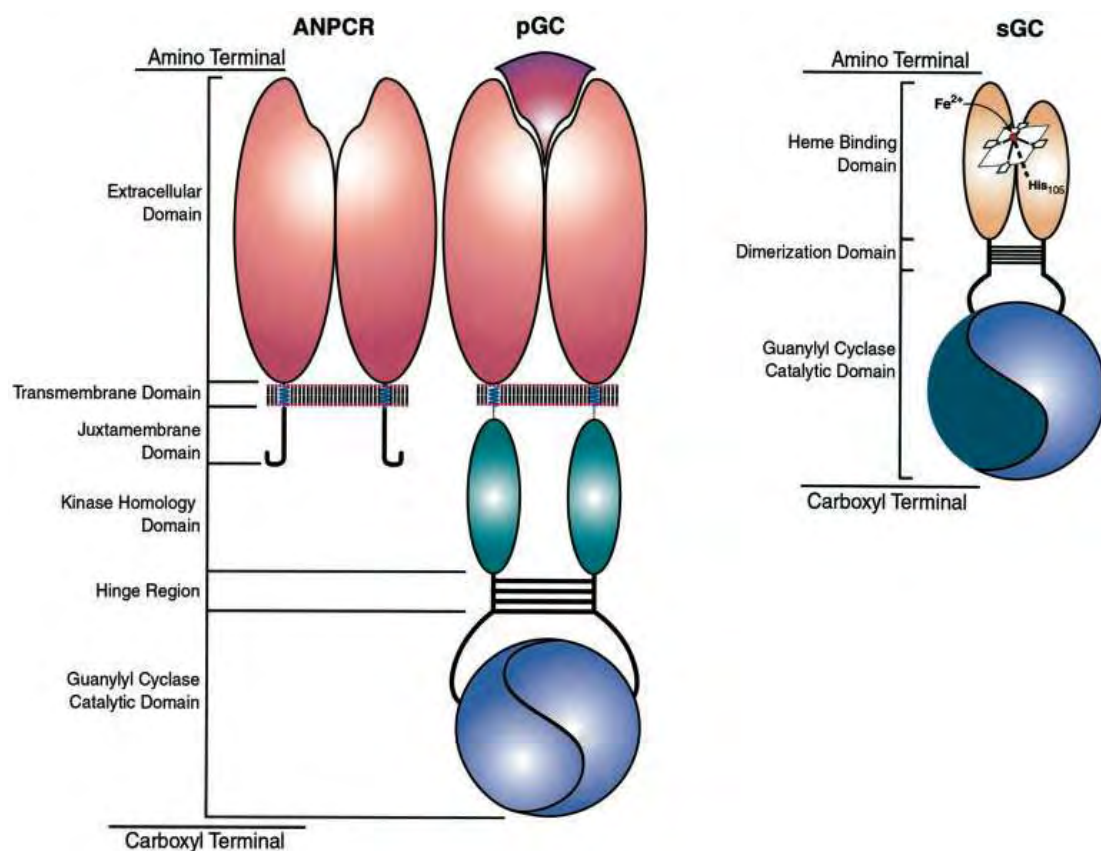

Picture 1

Domain structure of guanylyl cyclases. The cognate domains of ANPCRs, pGCs, and sGCs are compared. ANPCRs are homodimeric truncated guanylyl cyclases that possess extracellular ligand binding, transmembrane, and juxtamembrane domains but lack kinase homology, hinge, and catalytic domains. The pGC illustrated is a homodimer modeled after GC-A and -B and possesses a single ligand-binding site formed by two extracellular amino terminal domains. In addition to the domains present in ANPCRs, pGCs also possess kinase homology domains, hinge regions, and catalytic domains that form two functional catalytic sites. GC-C, -D, -E, and -F possess a carboxyl terminal tail that is not depicted here. sGCs are heterodimers possessing amino terminal regulatory domains containing a heme prosthetic group with a ferrous (Fe²⁺) core that forms an imidazole axial bond with His105 of the b-subunit. In addition, sGCs possess dimerization domains and carboxyl terminal catalytic domains that form one active and one inactive (flat blue) catalytic site. Colors identify domains with significant homology (Lucas et al., 2000, Guanylyl Cyclases and Signaling by Cyclic GMP. *Pharmacol. Rev.*52:375–413).

A.1.1.2 Soluble GCs (sGC)

The soluble guanylyl cyclases are expressed in the cytoplasm of nearly all mammalian cells and are involved in a wide variety of important physiological functions, such as preventing platelet aggregation, smooth muscle relaxation, vasodilatation, neurotransmission and immune-homeostasis. Composed of two subunits-a,-b, the expression of both is essential for the catalytic activity of the enzyme [2].

A.1.1.2.1 Regulation of sGC by ligands

- Nitrous Oxide (NO): It activates the sGC by binding directly to the heme ring. The CO has also the ability to bind directly to the heme but is a very weak activator of sGC compared to NO.
- Protoporphyrin IX (PPIX): The protoporphyrin is a precursor molecule of heme and is associated with high affinity to sGC.
- Divalent cations: Both pGC and sGC require divalent cations as substrate cofactors and allosteric regulators, in order to achieve the maximum catalytic activity of enzymes [2].

A.1.2 Action of cGMP

The specificity of the cellular response of cGMP depends on the binding of cGMP at different protein targets. “Two evolutionarily distinct allosteric sites for binding cGMP are present in eukaryotic cells. One occurs with significant sequence homology in PKGs and cAMP-dependent protein kinase (PKA) and in the cyclic nucleotide-gated (CNG) cation channels, while the other occurs in cGMP regulated PDEs”, describes Lucas et al. in his review (2000) [2].

A.1.2.1 cGMP dependent protein kinases

The PKGs (protein kinases dependent on cGMP) are the main intermediates in facilitating the transmission of intracellular signals by cGMP. When the guanylyl cyclases are activated by different ligands, cGMP concentration increases. Then, the cGMP binds to PKGs, and activates them to phosphorylate their protein targets.

Finally, the phosphorylated proteins convert the extracellular stimuli in a particular biological function. In mammals two different genes for PKG have been identified. One of them is located on human chromosome 10 and encodes for the PKGI and the other one on chromosome 4 and encodes for the PKGII.

The PKGI is a 76 kDa homodimer, strongly expressed in platelets, the cerebellum and in the smooth muscle cells. Through alternative splicing of the PKGI gene, two PKGI isoforms that differ in their N-terminal region and thus in the affinity for cGMP are produced, the PKGI α which is found mainly in thrombocytes, in the vascular system, kidneys and adrenal glands and PKGI β which is found primarily in the uterus. Experiments with PKGI knockout mice as reviewed by Lucas et al. (2000) showed that, cyclic GMP induced relaxation in aortic rings or gastric fundus muscle strips prepared from PKG I deficient mice was impaired, whereas cAMP-induced relaxation was not. These mutant mice were hypertensive and lacked regular intestinal peristalsis, indicating PKG I is the specific mediator of cGMP effects in smooth muscles, in vivo. Furthermore, there was a defective cGMP-mediated inhibition of the activation response in platelets from the mutant mice, whereas cAMP-mediated inhibition was not impaired. Another experiment showed that these mice developed anemia and splenomegaly in 10 weeks after birth [9]. The anemia was probably due to the short life of erythrocytes, and the splenomegaly may be due to accumulation of red blood cell precursors due to the increased erythropoietin, response to anemia [2].

The PKGII is an 86 kDa membrane bound homodimer. It is absent from the cardiovascular system, abundant in brain and intestine, and is also expressed in lung, kidney, and bone. The only known substrate of PKGII is the CFTR channel (cysticfibrosis transmembrane conductance regulator), the phosphorylation of which leads to an increased secretion of chloride ions and water. The PKGII has less affinity for cGMP than the PKGI [2-9].

A.1.2.2 Cyclic Nucleotides dependent ion channels

The CNG channels contain a binding site for cGMP in the carboxyl terminal, like the one that cyclic nucleotide dependent protein kinases have. The main category of CNG channels regulates the entry of Na⁺, K⁺ in the cells. These channels are four-domain proteins that "open" directly when cyclic nucleotides bind to them [2].

A.1.3 Degradation of cGMP- dependent phosphodiesterases (PDEs)

In order to stop the message in a signal transduction cascade through cGMP, the degradation of the original cGMP signal is of great importance. The phosphodiesterases degrade the signaling molecule cGMP, and thus they limit the time and spatial context of cGMP signaling.

At least 10 different gene families encoding for phosphodiesterases have been identified in mammals. Each enzyme contains an evolutionarily conserved region of 270 aa in the carboxyl terminus. "This domain cleaves the phosphodiester bond, hydrolyzing the 3', 5' cyclic monophosphate nucleotides to 5' monophosphate nucleotides" describes Lucas et al., (2000). The various PDEs perform very specialized functions. The categories 1,2,3,10, hydrolyze both cAMP and cGMP.

While, the 4,7,8 only cAMP and the 5,6,9 only cGMP. The PDEs regulate heart function, steroid production in the adrenal glands, photo-transduction and also erectile response in males [2, 7].

A.1.4 Motility of vascular smooth muscle

The mechanism of vascular smooth muscle contraction as described by A. Lange (2006) is regulated by Ca^{2+} ions. During muscle contraction Ca^{2+} concentration is increased. Calcium levels can increase either by opening of the L-type calcium channels or by binding of hormones (noradrenaline, angiotensin II vasopresin, serotonin, endothelin I) to GPCR receptors. These (GPCRs) in turn activate the phospholipase C, which cleaves PIP_2 into diacylglycerol (DAG) and inositol triphosphate (IP_3). The IP_3 increases calcium excretion from sarcoplasmic reticulum which activates the Ca^{2+} dependent, myosin light chain kinase. Through phosphorylation of the myosin light chain a muscle contraction is achieved. It has been found that the phosphorylation of myosin light chain can be also done regardless of Ca^{2+} , through the activation of the small GTPase RhoA, which activates the kinase of RhoA (ROK). In contrast during relaxation Ca^{2+} levels are reduced. This is achieved by increased cGMP or/and cAMP levels. Due to the reduction of calcium levels the activity of Ca^{2+} -dependent myosin light chain kinase is reduced. In another pathway, the increased cGMP levels activate PKGI which in turn phosphorylates and activates the myosin light chain phosphatase. The phosphatase of myosin light chain dephosphorylates the myosin light chain and thus reduces the actin-myosin interaction which leads directly to muscle relaxation. Additionally, the IRAG protein (*IP3-receptor-associated cGMP-dependent kinase-substrate*) can be also phosphorylated by the PKGI. This protein is associated with the PIP_3 receptor in the sarcoplasmic reticulum. Phosphorylation of IRAG leads to closure of the associated channels and results to decreased calcium levels facilitating thus muscle relaxation [2, 4].

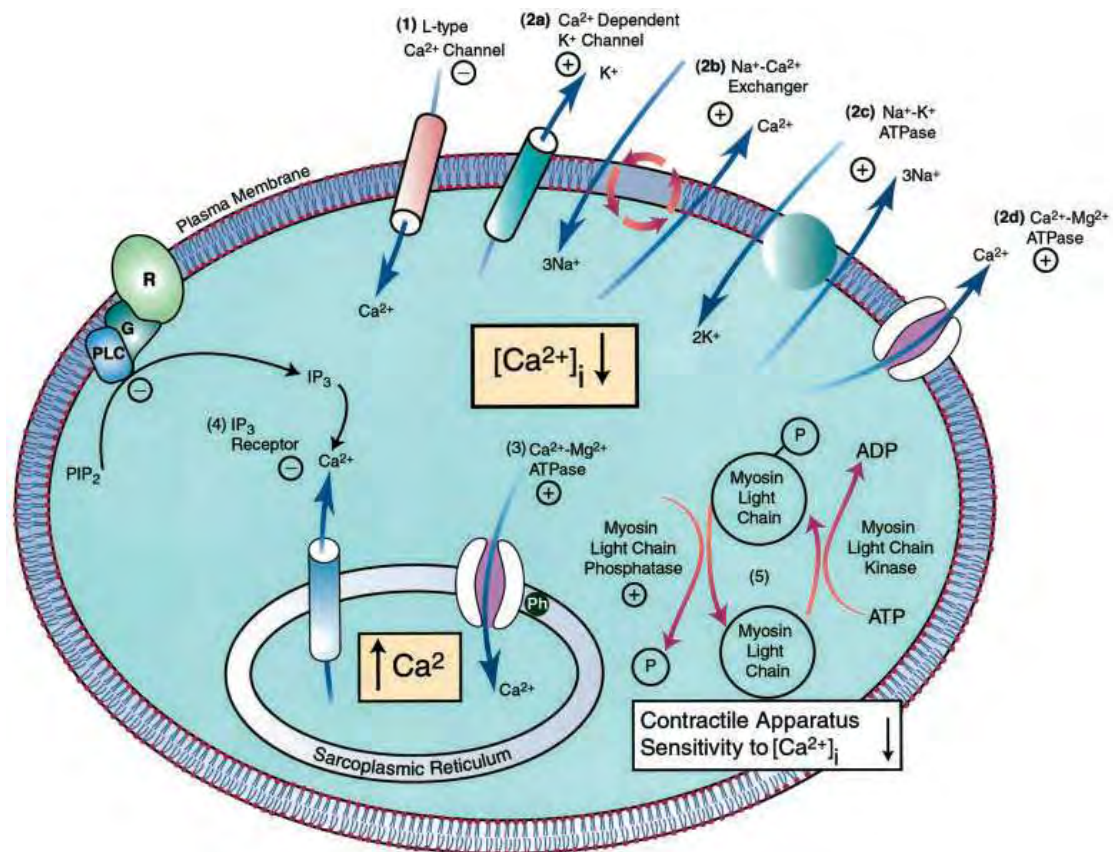

Picture 2

Molecular mechanisms underlying vascular smooth muscle relaxation mediated by cyclic GMP. Cyclic GMP induces smooth muscle relaxation by reducing $[Ca^{2+}]_i$ and desensitizing the contractile apparatus to Ca^{2+} . Cyclic GMP reduces $[Ca^{2+}]_i$ by (1) inhibiting Ca^{2+} influx through L-type Ca^{2+} channels; (2) increasing Ca^{2+} efflux through activation of (2d) the Ca^{2+} -pumping ATPase and (2b) the Na^+/Ca^{2+} exchanger; also, cGMP may produce membrane hyperpolarization through activation of (2c) the Na^+/K^+ ATPase and (2a) K^+ channels, thereby increasing Ca^{2+} extrusion by the Na^+/Ca^{2+} exchanger; (3) increasing of Ca^{2+} sequestration through activation of the sarcoplasmic reticulum Ca^{2+} -pumping ATPase [Ph, phospholamban]; and (4) decreasing of Ca^{2+} mobilization through inhibition of agonist-induced IP_3 formation or inhibition of the IP_3 receptor in the sarcoplasmic reticulum. R, receptor; G, G protein; PLC, phospholipase C; IP_3 R, IP_3 receptor. Cyclic GMP desensitizes the contractile apparatus to Ca^{2+} (5) probably by activating myosin light chain phosphatase, resulting in dephosphorylation of the 20 kDa myosin light chain (Lucas et al., 2000, Guanylyl Cyclases and Signaling by Cyclic GMP. *Pharmacol Rev* 52:375–413).

A.1.5 cGMP: A Drug Target

People with hypertension, hypercholesterolemia, nicotine consumption or diabetes mellitus have greatly increased risk for diseases of the vascular endothelium, i.e. situations in which blood vessels lose their elasticity and their ability to relax. This situation can lead by vasoconstriction to ischemic diseases in both heart and the brain so that these cells can even die. In such situations of endothelial dysfunction vasodilatory substances such as NO, are being produced in less quantity. Even the production of anti-thrombotic agents such as the PGI_2 is drastically reduced. After a disruption of the endothelium for example due to an inflammation, an increased

amount of LDL, thrombocytes and macrophages come to this area and create atheromatic plaques. The macrophages take in a big amount of LDL and become foam cells that secrete growth hormones. The smooth muscle cells proliferate and migrate in response to these hormones to other places creating thus atheromatic plaques. The blood swirls because of the plaques and causes mechanical rupture of blood vessels. To this point thrombocytes are activated and accumulate there while vasoconstriction helps to reduce blood loss. Often the creation of a large clot is favored so that the vessel is now completely closed, causing interruption of blood flow. Then we talk about myocardial infarction or stroke, regarding which organ lacks blood supply [4].

The therapeutic approach except for the administration of coagulant factors, also includes the use of nitrates (Nitroglycerine) which either by metabolism or not, will release NO in the blood, enough to cause vasodilation through a cGMP signaling mechanism as described above.

Another disease example where the usage of cGMP targeting drugs has helped a lot is the erectile dysfunction. Indeed, the sildenafil selectively inhibits PDE5 in the corpus cavernosum leading thus to increased cGMP levels that induce blood vessel relaxation resulting to erection [7].

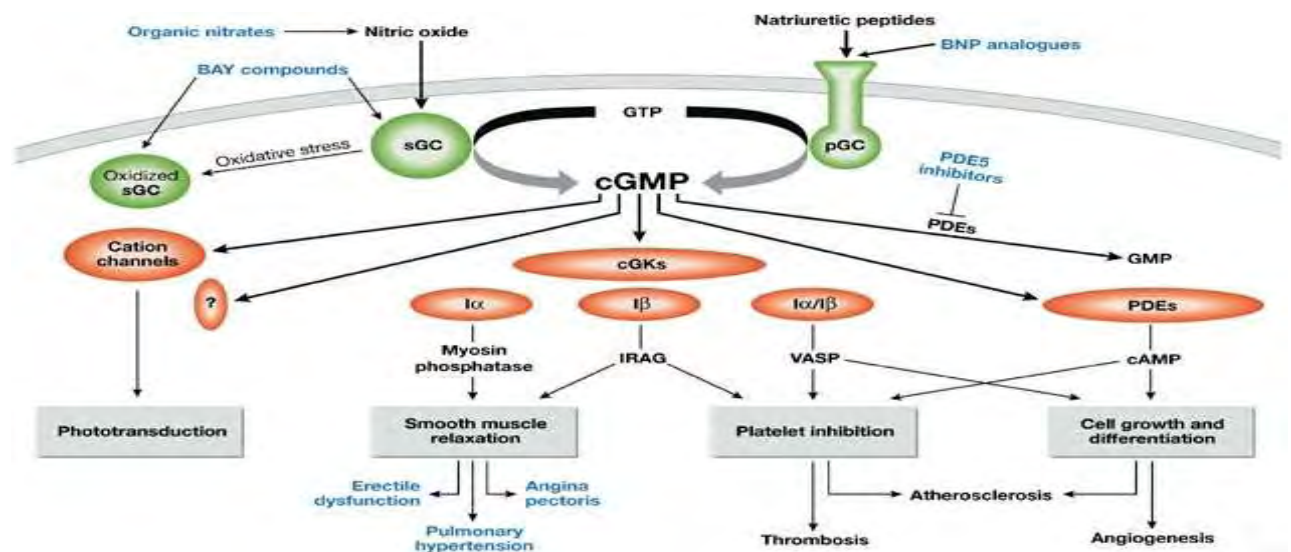

Picture 3

Current concepts of cGMP signalling. cGMP generators (green) and effectors (red), as well as some downstream pathways and cellular functions (grey boxes) that are involved in the effects of endogenous cGMP and/or cGMP-elevating drugs (blue), are shown. The lower part shows some current (blue) as well as potential future (black) indications for drugs that modulate cGMP levels or cGMP effector pathways. BNP, B-type natriuretic peptide; cGKs, cGMPdependent protein kinases; IRAG, IP3 receptor-associated cGKI β substrate; PDEs, phosphodiesterases; pGC, particulate guanylyl cyclase; sGC, soluble guanylyl cyclase; VASP, vasodilator-stimulated phosphoprotein (Robert Feil et al., 2006, cGMP signaling: from bench to bedside. EMBO Reports 7, 149-153).

One can easily realize with a quick view at the introduction (and the literature), the great research interest at the cGMP field, because of its extensive involvement in many (patho-) physiological functions. Finding the way, how all these factors interact with each other, stimulates since decades the scientific interest.

A.2 Site Specific Recombination (SSR)

Over the last decade site-specific recombinases-SSRs, such as Cre and Flp have become an essential tool for in vivo manipulation of the mouse genome. It is now possible to control the spatial and temporal initiation of a gene knockout in almost all tissues of the mouse leading thus to very "sophisticated" mouse models for human diseases and pharmacological research, explains Robert Feil (2007). SSR technology is also widely used for generating transgenic knockout models for cGMP signaling proteins such as the PKGI. Among other animal models, the mouse is preferred because of the plethora of genetic modifications that it can undergo and because of the quick way it breeds and develops in the laboratory. In addition to these so far it is the only organism for which there are embryonic stem cells available that can be used for gene targeting and production of transgenic models. The foreign DNA can be integrated at random positions within the mouse genome. This random integration is usually achieved by microinjection of the foreign DNA into the male pronucleus of a fertilized egg, but also other methods such as viral transfection to the oocyte or ES cell transfection are available. The random integration is mainly used for gene over-expression because the foreign DNA can be integrated in multiple copies in the mouse genome. Without any doubt this technique has provided a great deal of understanding in the gene function of mammals. But since the integration has been made in the germ line, this means that the foreign DNA is present in all body cells during animal's life (total knockout model). For example, when a knockout is lethal for the embryo and therefore its contribution to the phenotype of the animal in later stages cannot be studied, or when we want to study the effect of a knockout at a particular stage in organism's life or even large chromosomal rearrangements (deletions, duplications, translocations) the method mentioned above is not suitable. These restrictions have now been overcome with the site-specific recombination. The site-specific recombination is based on site-specific recombinases that can cut and paste DNA fragments between specific recognition sites and thus it is able one to generate specific changes in the genome of the organism [11-13].

A.2.1 Basic Principles of Site Specific Recombination

Unlike homologous recombination that can occur between any two homologous sequences, site specific recombination is characterized by the mutual exchange of DNA fragments between two specific recognition sites and it is achieved by site-specific recombinases. The necessary tools for the site specific recombination are a pair of specific recognition sites and a recombinase that recognizes these sites. The result depends on the position and orientation of the recognition sites [11].

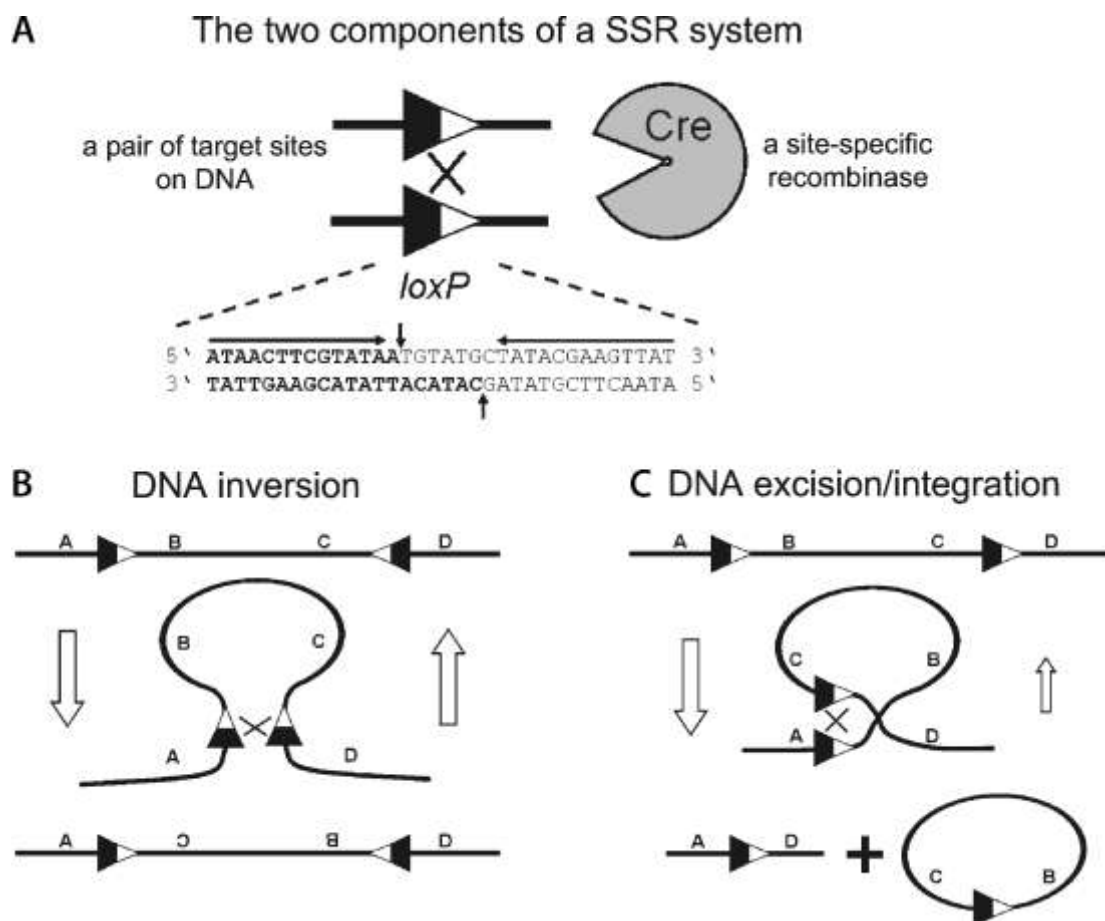

Picture 4

Basic principles of site-specific recombination as illustrated by the Cre/lox system. **A** The Cre recombinase (*pacman*) promotes reciprocal strand exchange between two 34-bp *loxP* target sites (*triangles*). Each *loxP* sequence consists of two 13-bp inverted repeats (*horizontal arrows*) flanking an 8-bp asymmetric spacer sequence that confers overall directionality. After binding of one Cre monomer to each inverted repeat, the DNA strands are cleaved in the spacer region (*vertical arrows*), exchanged between the two *loxP* sites, and ligated. The two half-sites of the *loxP* sequence that are recombined in a reciprocal manner are indicated by the *black and white segments of the triangles* and by *bold and standard lettering*. Note that the recombination reaction is conservative, i.e. it does not involve any net synthesis or loss of DNA so that two new functional *loxP* sites are generated. **B** Recombination between two *loxP* sites inserted into the same DNA molecule (intramolecular recombination) in opposite orientation leads to inversion of the intervening DNA segment. **C** Recombination between directly repeated *loxP* sites results in excision of the flanked DNA (circular product that is degraded) leaving one *loxP* site behind. When the *loxP* sites are located on separate DNA molecules (*lower part*), intermolecular recombination can lead to DNA integration. For kinetic reasons, DNA excision is strongly favoured over integration and, due to degradation of the circular product, can be considered irreversible. The dimensions of the *white arrows* indicate the relative efficiencies of the respective recombination reactions (Robert Feil, 2007, Conditional somatic mutagenesis in the mouse using site specific recombinases. HEP 178:3–28).

“In the 90s several laboratories around the world showed that a particular site-specific recombination system, the Cre / lox system, works surprisingly well in the mouse and it can be used to generate tissue-specific and inducible knockout mice”, describes Robert Feil (2007).

“The Cre recombinase (cyclization recombination) is a 38 kDa protein encoded by the bacteriophage P1, which recombines the two 34-bp target sites on the P1 genome called *loxP* (locus of crossing-over [X] of P1) without the need for any co-factor” says Robert Feil (2007). The *loxP* sequence consists of two 13-bp inverted repeats flanking an 8-bp asymmetric spacer region that confers overall directionality. The Cre recombinase binds to the two inverted repeats of the loxP sites and catalyzes the excision of the intermediate fragment. On the other hand, the Flp recombinase (*S. cerevisiae*) recombines the part between two FRT sites, but with less efficiency, when compared to Cre [11].

A.2.2 Genome Engineering strategies using SSRs

“The basic strategy for SSR-directed genetic engineering is to insert the SSR recognition sites into the chromosomes, and then to deliver the SSR to recombine them as required”, mentions R. Feil in his review (2007). Then the recombinase recombines the fragment between the recognition sites. This technology allows genetic modifications in selected somatic cells. The most popular system for this purpose is the Cre / lox system and it is used to generate time- and tissue-specific knockout mice. The site specificity of Cre can be directed by Cre recombinases that are expressed in specific tissues only, while the time-specificity with ligand-activated Cre recombinases. Generally, a transgenic mouse is produced by mating a mouse carrying the loxP sites on both sides of the gene that will be knocked out, with another one which expresses the Cre recombinase selectively in a tissue. To generate a “flanked” mouse, the two loxP sites surrounding the gene of interest (that will be knocked out) are introduced by homologous recombination in ES cells. The ES cells are then cultured, selected and injected into blastocysts. These blastocysts are then introduced to a foster mother to develop to mice. For a Cre mouse, the integration of the Cre transgene downstream of a tissue-specific promoter is mainly achieved by random integration in the mouse genome. By crossing these two mice the flanked gene is excised in that particular tissue that expresses the Cre. Also, this system can be used to achieve large-scale chromosomal rearrangements. The precise control of Cre expression marks the success of the transgenic animal. One method to test the activity of Cre is to fuse it with the GFP or beta-galactosidase, so that it can quickly become clear whether the Cre is being produced or not. Another possibility is the LacZ Cre reporter mouse [18]. In this case a LacZ cassette is targeted into Rosa 26 locus (knock in) leading thus to ubiquitous expression of the LacZ gene construct. X-Gal staining is present in all cells where the Cre recombinase is expressed. In every case though, Cre expression as well as the gene product should be also checked by molecular techniques [11].

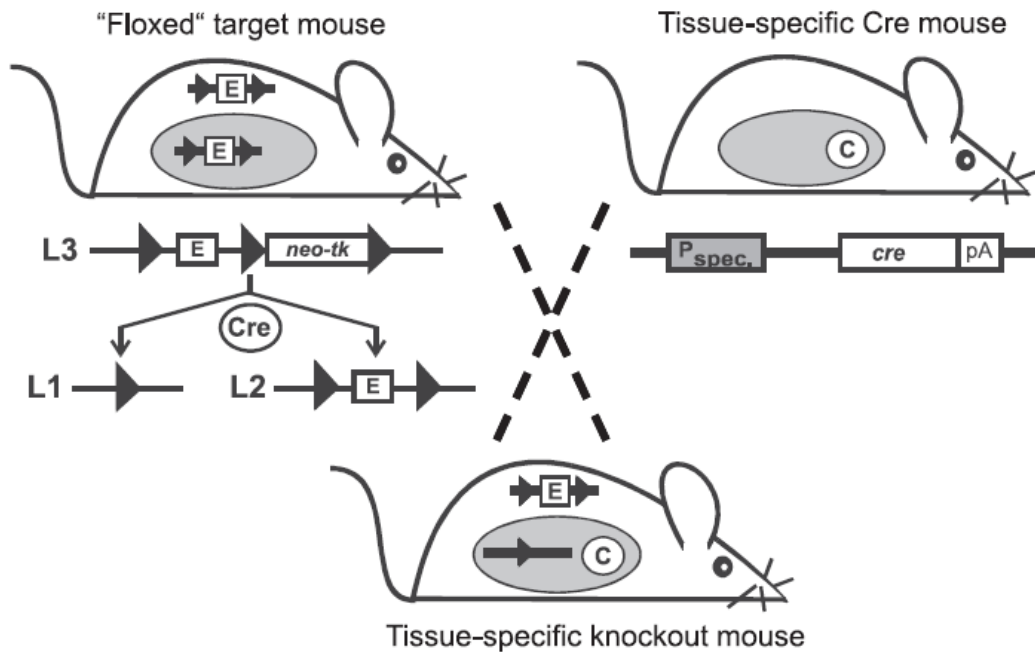

Picture 5

Generation of a tissue-specific knockout mouse. Two mouse lines are required, a floxed target mouse and a tissue-specific Cre mouse. The floxed target mouse (*left*) is generated by homologous recombination in ES cells. A popular strategy is to integrate a DNA construct that harbours three directly repeated *loxP* sites (*triangles*) flanking an essential exon (*E*) together with a selectable marker cassette (*neo-tk*) into the target locus, thereby generating a potentially hypomorphic tri-*lox* (*L3*) allele. The next step is to express Cre in the correctly targeted ES cell clones (or later in the respective mice) in order to convert the *L3* allele by selective excision of the selection cassette to the conditional floxed (*L2*) allele. Note that complete excision generates a null (*L1*) allele that can be used as an alternative to a conventional gene knockout (see Fig. 2a). Whereas the *neo* gene (neomycin phosphotransferase) is used to select for ES cells that have integrated the DNA construct (positive selection with G418), the *tk* gene (herpes simplex virus thymidine kinase) is useful in the second step to select for cells that have undergone Cre-mediated excision of the *neo-tk* cassette (negative selection with ganciclovir). The tissue-specific Cre mouse (*right*) is in most cases generated by random integration of a *cre* transgene (containing a polyA signal sequence, *pA*) that is driven by a tissue-specific promoter (*P spec.*) to express Cre in the cell type of interest (*shaded oval*). Intercrossing of the floxed target mouse and the tissue-specific Cre mouse results in offspring (*bottom*) in which the floxed target exon is being excised in all Cre-expressing cells (*shaded oval*), thereby generating a tissue-specific knockout mouse (R. Feil, 2007, Conditional somatic mutagenesis in the mouse using site specific recombinases. HEP 178:3–28).

B Chromosomal translocation

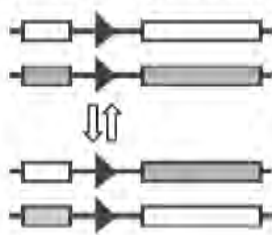

Picture 6

B Chromosomal translocation. By placing the *loxP* sites (*triangles*) on different chromosomes, chromosomal translocations with specific breakpoints can be created, for example, to model certain human cancers. Cre-mediated translocations are feasible between homologous or heterologous chromosomes. Note, however, that the efficiency of Cre-mediated interchromosomal rearrangements, in particular in the case of non homologous chromosomes, is fairly low, presumably reflecting chromosomal position within the cell during interphase and mitosis (R. Feil, 2007, Conditional somatic mutagenesis in the mouse using site specific recombinases. HEP 178:3–28).

A.2.3 Ligand-Activated SSRs

“In many cases, tissue-specific genome modifications would be more informative if they could be induced at will at a chosen time during the life of the animal”, reviewed Robert Feil (2007). Thus potentially toxic effects of Cre could be avoided. The standard approach for the external control of the temporal onset of site specific recombination is to use ligand-dependent SSRs that can be selectively activated by synthetic drugs. The observation that the activity of a protein can be controlled by a ligand when it is fused to Ligand Binding Domain, LBD of the steroid hormone receptors led to the development of ligand activated-Cre recombinases (CreLBD). Further optimization of the technique leads to the CreLBDs that can respond only to synthetic ligands. Conjugation of Cre with a modified estrogen receptor (ER) can activate the Cre recombinase by the drug tamoxifen. In fact, in absence of the ligand, the chimeric Cre is located in the cytoplasm, whereas binding of ligand results in translocation of the Cre to the nucleus where it recombines the loxP-flanked DNA. The CreER^T recombinase that can be activated by 4-hydroxytamoxifen but not by the endogenous β -estradiol, has been particularly useful for in vivo site-specific recombination uses. Of course, sometimes side effects can occur from high doses of tamoxifen. That is why several optimization modifications have been made to the original CreER^T. Indeed, the CreER^{T2} is ten times more sensitive to tamoxifen than the initial CreER^T. It is worth noting that the route of administration (dose, route, frequency) can significantly affect the recombination result and therefore they should be carefully determined before each experiment. Finally, other inducible systems such as tet-on and tet-off Cre system have been reviewed in literature, but there are significant drawbacks in these [11].

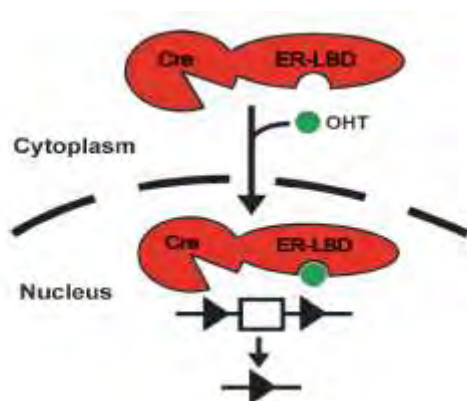

Picture 7

How do ligand-dependent Cre recombinases work? These recombinases are fusion proteins between Cre and the ligand-binding domains (LBDs) of steroid receptors. The LBD has been mutated so that it does not respond to its natural ligand yet binds a synthetic ligand. The scheme (*left*) illustrates the current model with the tamoxifen-activated CreER^T recombinase (*modified pacman*), a fusion of Cre with a mutated estrogen receptor (ER) LBD that responds specifically to the synthetic drug 4-hydroxytamoxifen (OHT) but not to β -estradiol. In the absence of OHT, the recombinase is located in the cytoplasm. Binding of OHT to the LBD results in the translocation of the recombinase into the nucleus where it can recombine its *loxP* substrates (*triangles*) (Robert Feil, 2007, Conditional somatic mutagenesis in the mouse using site specific recombinases. HEP 178:3–28).

A.2.4 Other Applications of genetic modified mice

Transgenic mice have been shown to be very useful tools in drug research and human diseases research. Clearly one of the most powerful capabilities of the SSR technology is human cancer modeling. Indeed, one of the first applications of this technique was to delete and thus activate an oncogene in mice. Recently, the technique has been used to create chromosomal rearrangements (translocations) just like the ones that occur in many human cancers. The tracking of cell lineage is yet another application of SSR technology. It is now possible to track cells by coloring them, as the color is stable over a lot of proliferations or cell migration. It is then easy to scan for these cells and watch where they have migrated or settled. Another possibility is to make cells accumulate a radioactive substance which could be easily detected. And then simply detect the radiation. The technique is very promising and it is believed that would help understand many human diseases such as metastasis in cancers or atherosclerosis etc [15, 16].

A.3 The cGi-500 sensor

Due to the great importance of signaling through cGMP, is often required to monitor cGMP levels in real time. Until now, cGMP is being measured by RIA or ELISA in cell lysates, while another possible method is by using a cGMP antibody. But the key problem is that the methods are not rapid and one has to fix the cells or the tissues. Moreover cGMP levels exhibit a maximum after stimulation with certain agents and then decrease so that it there is an urgent need for sensors that can record changes in time that they are actually happening and of course in living cells/tissues.

So far, several attempts have been made to build such sensors. All of them consisted of an area where cGMP could bind (cGMP-binding domain), and of two different fluorescent proteins on each side, ECFP and EYFP. The new concept consisted of cGMP binding sites (either one: A, or two: A + B) taken from PDE5 and the PKGI. Regarding to the constructions with binding sites from PDE5, although they showed high affinity to cGMP, they exhibited extremely slow kinetics in binding and disassociation of cGMP at low concentrations. On the other hand, the constructions that contained two binding sites from PKGI (A + B cNMP BD), responded very quickly to changes in the concentration of cGMP and showed an 80% increase in emission ratio of CFP / YFP. Three sensors that were obtained with this technique were named based on their EC₅₀. The cGi500: 500nM, cGi3000: 3 μ M, cGi6000: 6 μ M. These sensors showed fast cGMP binding and disassociation kinetics and high affinity for this molecule. The function principle is that the EYFP and ECFP function

as a donor-acceptor pair for fluorescence resonance energy transfer (FRET), in which excitation of the donor (cyan) molecule at 436nm, leads to emission from the acceptor (yellow) molecule at 525nm, provided that the proteins are close enough (<10 nm) for energy transfer to occur. On the other hand when cGMP binds to the sensor its conformation changes (linear) so that the two fluorescent proteins are not close enough for FRET. In that case the excitation of the CFP at 436nm leads to emission of the same molecule at 475nm. The sensor can be monitored with a dual emission fluorescent microscopy system recording for the CFP and the YFP (FRET) emission at the same time [14].

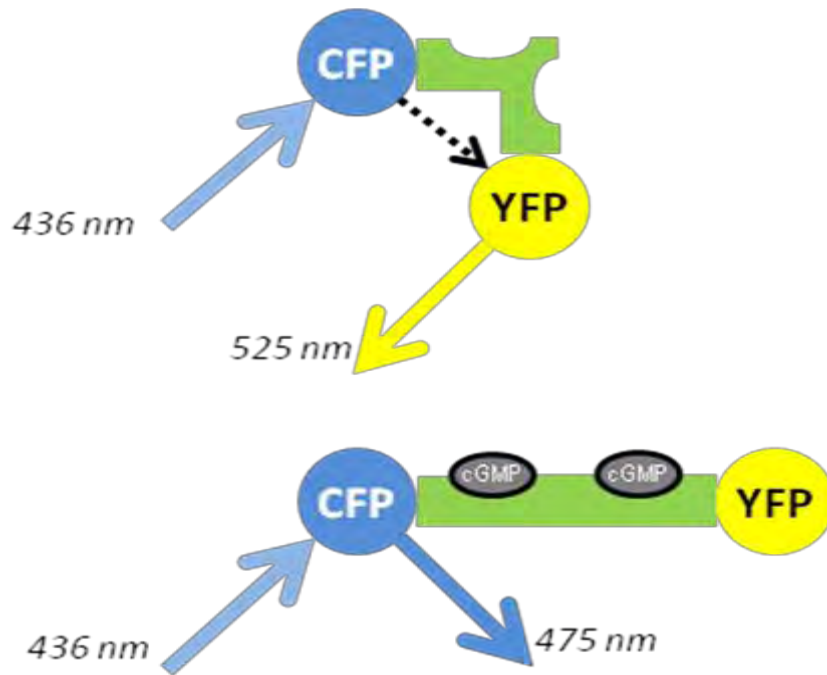

Picture 8

Schematic representation of the cGi-500 sensor without (above) and with cGMP. In absence of cGMP the excitation of the donor (CFP) at 436 nm leads to an emission of the acceptor (YFP) at 525 nm (FRET). While when cGMP is bound to the sensor the excitation of the donor (CFP) at 436 nm leads to an emission from the same molecule at 475 nm (the pictures were drawn by Martin Thunemann).

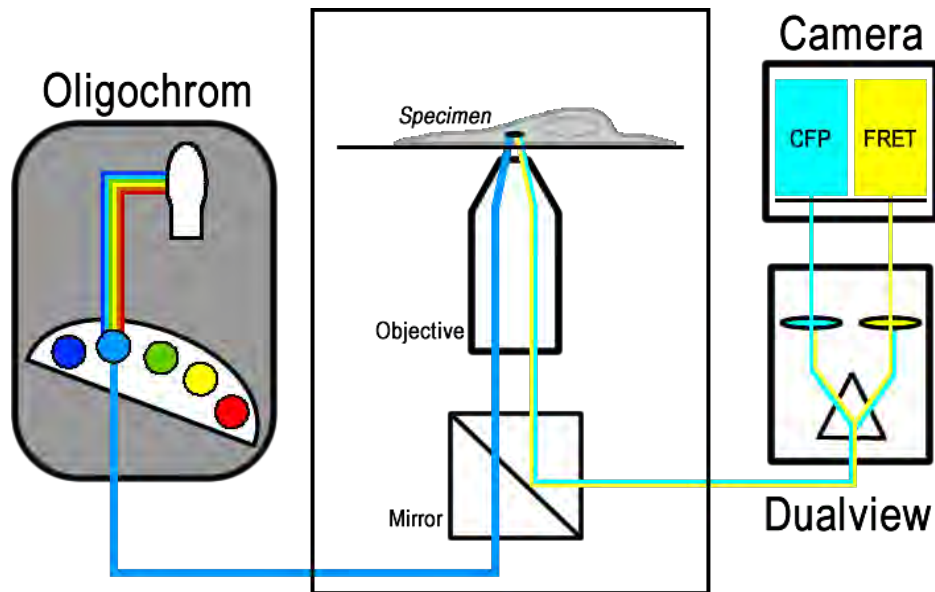

Picture 9

The above picture shows a schematic representation of the way this measuring procedure works. A light source at 436 nm excites the sample, which in turn emits light at 475 nm (CFP) or/and at 525 nm (FRET) because it consists of sensors with and without cGMP respectively. A dual recording system records both colors which are then analyzed by a computer. A **CFP** signal indicates sensors **with cGMP** bound on them, whereas a **FRET** signal denotes sensors **without cGMP** bound on them (the pictures were drawn by Martin Thunemann).

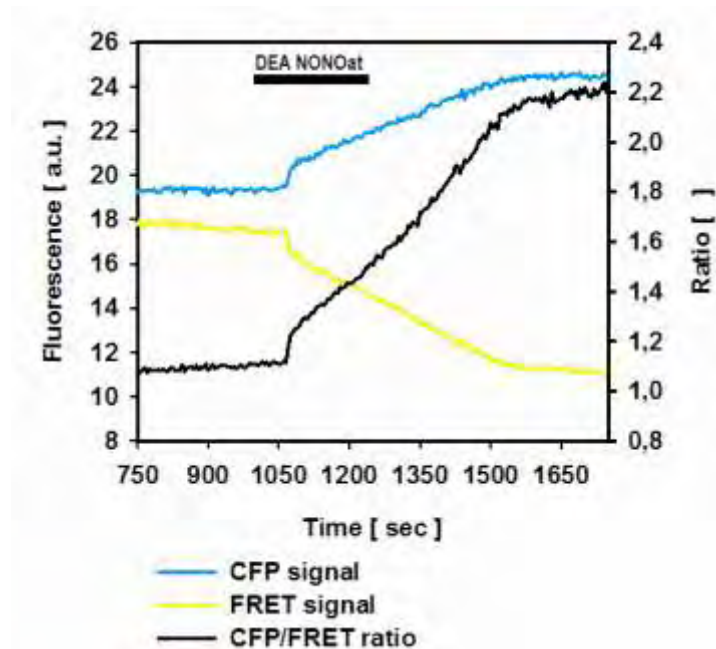

Picture 10

The diagram (pic. 10) results after cGMP measurements with the sensor. After a particular time (e.g. 1050 sec) a drug that has been administrated to the cells increases the intracellular cGMP. This leads to conformational changes to the sensor altering thus the emission pattern. The CFP signal increases (cGMP binds to the sensors) while the FRET signal reduces (fewer sensors without any cGMP bound to them) [Martin Thunemann, personal communication].

A.4 The Rosa26mT/mG plasmid

“So far dozens of different Cre mice have been created, each of them requires careful characterization of spatial and temporal expression of Cre”, as describes Mandar Deepak Muzumdar (2007). Not only that, but “also questions of great biological interest such as those concerning cell morphology and cell lineage tracing are only a few of the examples, why such a reporter system is needed” explains Martin Thunemann. For this purpose specific transgenic mice have been constructed so that they will express a particular marker (LacZ, GFP, CFP or YFP) after Cre recombination. But in order to assess the number of tissues in which Cre is active, a double-labeling system for cells is important. For example expression of a marker (LacZ) prior to Cre recombination and another different marker (GFP) after Cre recombination. In contrast to the older systems, a double fluorescent reporter could allow the visualization of non-recombined and recombined cells without using any exogenous enzyme substrate. While the green fluorescent protein GFP was used since decades in biological research, a newly introduced red fluorescent protein (RFP) had not gained ground because of the toxicity that caused. Recently, a great number of new red fluorescent protein variants were developed to overcome the existing problem. One of them, the tandem dimmer Tomato (tdTomato) was particularly selected for its outstanding brightness and the photostability and because it also showed reduced toxicity [1].

By combining the two fluorescent proteins came of a new Cre double fluorescent indicator, the mT/mG. This indicator is a membrane-targeted version of the tdTomato surrounded by two loxP sites, followed by a membrane-targeted GFP (downstream of the strong CAG promoter (β -actin, and the enhancer of CMV) [17]. All the mice generated with the above construct, expressed the mT protein, while all Cre recombined cells were mG positive. The cassette was targeted into Rosa26 locus (6th chromosome), as this is expressed in all cells, without falling into heterochromatin. Although the endogenous Rosa promoter is not so strong, the CAG promoter targeted into Rosa26 locus results in high expression levels of the double reporter transgene. Furthermore, homozygous and heterozygous knock-in mice are viable, fertile and without any phenotypic changes [1].

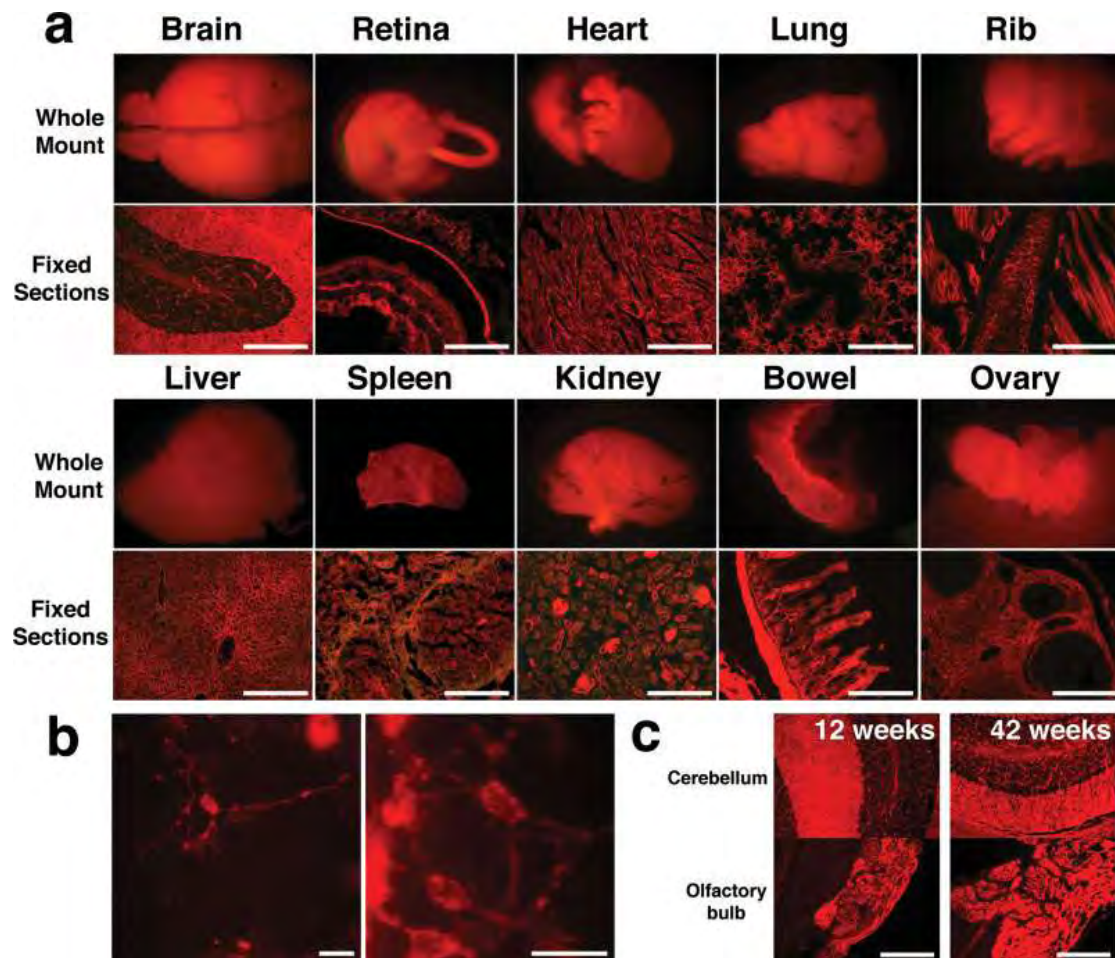

Picture 11

1. Ubiquitous mT labeling in mT/mG mice prior to recombination. (a) Live whole mount and fixed tissue sections of various organs from an adult mT/mG mouse demonstrating ubiquitous mT labeling. (b) Examples of individual live mT-labeled cultured neurons derived from embryonic cortical caps of mT/mG mice. (c) mT/mG cerebella and olfactory bulb glomeruli reveal no difference in mT fluorescence between mice at 12 versus 42 weeks of age. Scale bars: (a) 200 μ m, (b) 50 μ m, (c) 200 μ m. (Muzumdar et al., 2007, *A Global Double-Fluorescent Cre Reporter Mouse*. *genesis* 45:593–605)

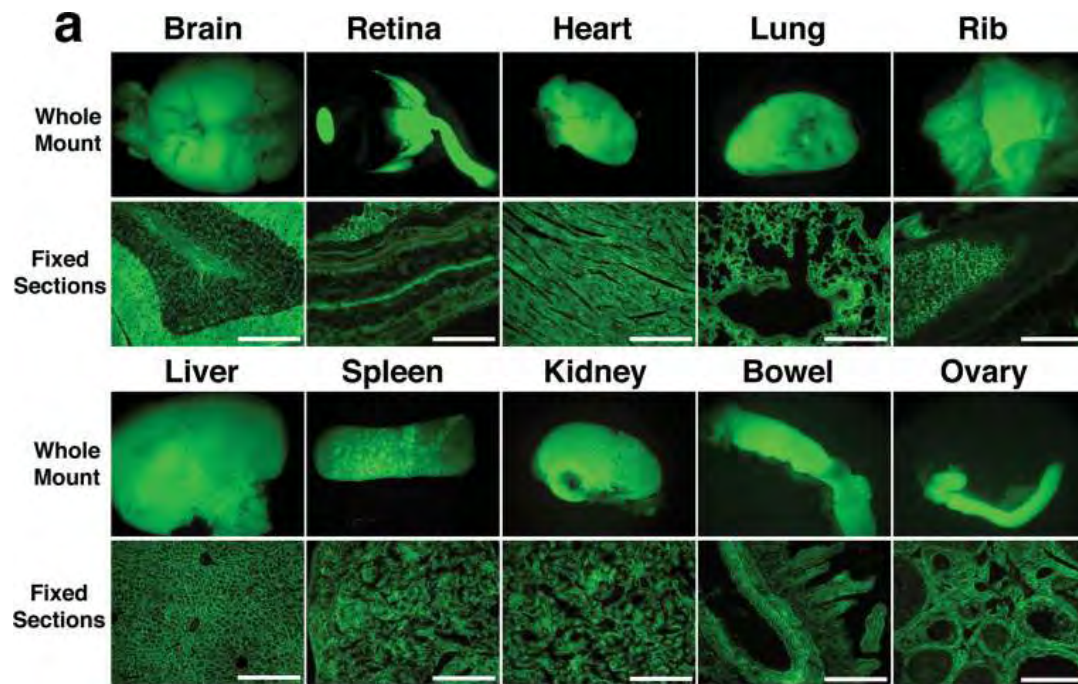

Picture 12

mG labeling in mT/mG mice after Cre-mediated recombination. (a) Live whole mount and fixed tissue sections of various organs from an adult mT/mG;hprt-Cre mouse demonstrating global mG labeling. Images represent composite of red and green channels, indicating minimal red fluorescence. (Muzumdar et al., 2007, A Global Double-Fluorescent Cre Reporter Mouse. *genesis* 45:593–605)

A.5 Aim of this work and strategy

In this project we used the plasmid Rosa26mT/mG [1] as a starting point to generate a targeting vector with a Multiple Cloning Site, where it could be sub-cloned any gene of interest. The main reason was the strong CAG promoter (CMV enhancer +chicken β -actin promoter) that drives high level expression of the transgene and also the fact that this targeting vector has been successfully used to generate a well working 'mouse line' (see § A.4). The process involved the excision of the mG fragment from the Rosa26mT/mG plasmid and then its replacement by a MCS. In order to manage this, the mG fragment should be removed by the enzymes *HindIII/EcoRI*, something that was not possible, as these enzymes cut several times in the homologous recombination arms, so that the original targeting vector was cut into small pieces. Therefore, the primary targeting vector was digested with *Ascl/Pacl* and the fragment containing the CAG promoter, the loxP-mT-loxP, the mG, and the FRT-Neo-FRT (7,2 kb) was sub-cloned into a small plasmid vector constructed for this purpose, (pLinker3 2,6 kb) based on pUC19. From then on it was possible to isolate the mG by *HindIII/EcoRI* and replaced it by a MCS that contained unique restriction enzyme sites in the whole targeting vector. Then the MCS containing fragment was cloned again back to the original targeting vector. In the MCS we sub-cloned the thymidine kinase (sr39tk) and the cGi500 sensor. Additionally some smaller plasmids containing the CAG promoter, the floxed mT and the MCS were generated for expression in eukaryotic cells.

B. Materials and Methods

B.1 Materials

B.1.1 Chemicals

Bovine Serum Albumin (BSA)	Roth
Chloroform (CHCl ₃)	Roth
EDTA	Roth
HCl	Roth
HEPES	Roth
LB Agar	Roth
LB Broth	Roth
NaCl	Roth
NaHCO ₃	Roth
NaOH	Roth
SDS (Sodium dodecyl sulfate)	Roth
Tris	Roth
Agarose	Biozym
Ethanol (EtOH)	VWR
Ethidium Bromide (EtBr)	Roth
Gluceronol	Roth
Isopropanol	Roth
Sodium acetate	Roth
Phenol:Chloroform:Isoamylalcohol 25:24:1	Roth

B.1.2 Enzymes

B.1.2.1 Restriction Enzymes

<u>Enzyme</u>	<u>Provider</u>
Ascl	NEB
AseI	NEB
AsiSI	NEB
BamHI	NEB
BspEI	NEB
EcoRI	NEB
EcoRV	NEB
FseI	NEB
HindIII	NEB
Kpn2I	Fermentas
MluI	NEB
NcoI	NEB
NdeI	NEB
NheI	NEB
NotI	NEB
PacI	NEB
Scal	NEB
XbaI	NEB
XhoI	NEB
XmaI	NEB

B.1.2.2 DNA/RNA modifying enzymes

<u>Enzyme</u>	<u>Provider</u>
Antarctic Phosphatase	NEB
CIP	NEB
RNAase	ROTH
T4-DNA Ligase	NEB
T4-Polynucleotide Kinase	NEB

B.1.3 Buffers

B.1.3.1 DNA isolation Solutions

S1 (Resuspension Buffer)

50 mM Tris-HCl

10 mM EDTA

100 µg/ml RNAase

pH=8,0

S2 (Lysis Buffer)

200 mM NaOH
1% SDS

S3 (Neutralization Buffer)

2,8 M KAc
pH=5,5

N2 (Column Equilibration Buffer)

100 mM Tris
15% EtOH
900 mM KCl
0,15% Triton X-100
pH=6,3 (H₃PO₄)

N3 (Washing Buffer)

100 mM Tris
15% EtOH
1,15 M KCl
pH=6,3 (H₃PO₄)

N5 (Elution Buffer)

100 mM Tris
15% EtOH
1,0 M KCl
pH=8,5 (H₃PO₄)

B.1.3.2 Cell Culture Buffers

PBS

135 mM NaCl	4 g
3 mM KCl	100 mg
8 mM Na ₂ HPO ₄ x 2H ₂ O	710 mg
2 mM KH ₂ PO ₄	120 mg
Ad to 500 ml H ₂ O	
pH=7,4 (NaOH), autoclave	

Trypsin

9 parts PBS
1 part 10x Trypsin/EDTA (Invitrogen)

DMEM

Dulbecco's Modified Eagle Medium
(Invitrogen)
Glutamax[™] (Dipeptide L-Alanyl-L-Glutamin)
4500 mg/l D-Glucose+ Sodiumpyruvate

100x Penicillin/Streptomycin
invitrogen, 10.000U/ml/ 10.000U/μg/ml

DMSO Dimethylsulfoxid

B.1.3.3 LB-Agar

Weight 35 g/L. Autoclave before use

B.1.3.4.1 LB-Medium

Weight 20 g/L. Autoclave before use

B.1.3.4.2 1x TBE Buffer

For 1 L 1xTBE Buffer:

10,8 g (89 mM) TRIS
5,5 g (89 mM) Boric Acid
0,7 g (2 mM) EDTA-Na₂

B.1.3.4.3 6x Gel Loading Buffer

30% Glycerol
0,05% Bromophenolblue
0,05% Xylencyanol dH₂O to 10ml

B.1.3.5 Antibiotics (Ampicillin)

Add 1 g Ampicillin in 10 ml dH₂O and filtrate to sterilize

B.1.4 Synthetic Oligonucleotides

B.1.4.1 Sequencing Primers

MH15: GTAGCGGCTGAAGCACTGCAC

M13uni (-43): AGGGTTTTCCCAGTCACGACGTT

B.1.4.2 Oligonucleotides used for cloning

For pLinker5 construction:

```

                |HindIII|      |EcoRI|      | AsiSI  |
          | FseI  |  |NcoI  |      |BamHI|      | MluI  |
aattggccggccagccatggaagcttggatccgaattcacgcgtgcgatcgc
ccggccggtcggtaccttcgaacctaggcttaagtgcgcacgctagcgtcga

```

For Multiple Cloning Site (MCS) construction:

```

                |XmaI  |                          | MluI  |
          | FseI  |                          | AsiSI  |
ccggaggccggcccggtatcagtggcgatcgcacgcgctc
tccggccggggcccatagtcaccgctagcgtgcgcagagct

```

B.1.5 Bacteria

We used the *E.coli* XL1- Blue.

XL1-Blue Genotype: *recA1 endA1 gyrA96 thi-1 hsdR17 supE44 relA1 lac* [F' *proAB lacIqZΔ M15 Tn10* (Tetr)].

B.1.6 1 kb Ladder

0.9% agarose gel

Stained with ethidium bromide

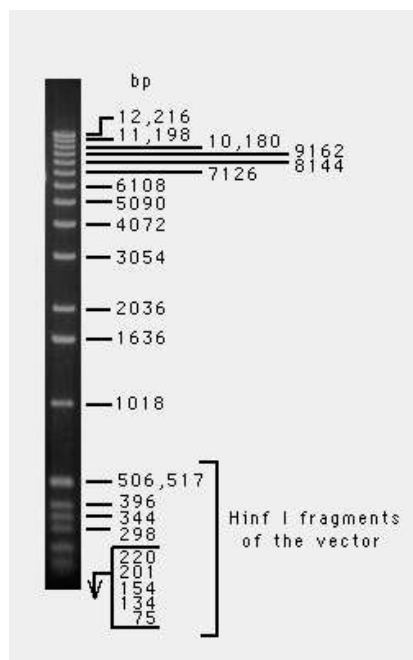

Methods

B.2 Molecular Biology Methods

(Obtained from the diploma thesis of Matthias Hillenbrand: "Herstellung und Charakterisierung Rekombinanter Bakuloviren für Biochemische Untersuchungen an der cGMP –abhängigen Protein Kinase, ,Tübingen, Dec. 2007)

B.2.1 Nucleic Acids Quantification

B.2.1.1 Photometric assessment of Nucleic Acids concentration

Determining the concentration of nucleic acids by measuring the optical density (OD) is a quick and easy method, however due to the requirement in big quantities of nucleic acid is mainly used in nucleic acids found in big quantities (maxi-prep) and pure oligonucleotides.

The spectrophotometer is blanked with 990µl dH₂O in a clean cuvette. Then 10 µl of the solution of the nucleic acid is added. The optical density is measured at 260 nm (for DNA). 1 OD_{260nm} equals to 50 µg/ml dsDNA and 33 µg/ml oligonucleotide. The average of two measurements is then multiplied by 50*100 (dilution) and the result is in ng/µl. A sample purity indication is the OD_{260nm} / OD_{280nm} ratio. A value between 1.7 and 2 indicates that the sample is free of proteins.

B.2.1.2 Gel Agarose Quantification.

This method though not highly accurate offers a quick idea of the concentration of a nucleic acid in a sample. For this purpose a small amount of a sample is loaded (or different aliquots of a sample) in an Agarose Gel, and the thickness of the bands obtained is compared with known concentration of DNA bands or the bands of the molecular weight marker.

B.2.2 Oligonucleotides

It is possible to synthesize oligonucleotides that are going to be used as primers in a PCR or as an insert in a cloning strategy. These oligonucleotides are delivered by each biotech company (in this case: MWG Biotech Ebersberg) in a lyophilized form that should be diluted with dH₂O to a final concentration of 100 pmol/µl. Because the oligonucleotides are synthetically prepared, they lack 5' phosphate group, which must be added enzymatically if they are going to be used as inserts for cloning.

B.2.3 Enzymatic Manipulation of DNA.

B.2.3.1 Phosphorylation of 5' ends of oligonucleotides

The 5' phosphate group of a DNA molecule is essential for a successful cloning. The following protocol describes the addition of a phosphate group in two complementary

oligonucleotides in a reaction and ensures the correct final configuration of the double helix.

1. For an End volume of 20 μ l:
 - 1 μ l Oligonucleotide A (100 pmol/ μ l)
 - 1 μ l Oligonucleotide B (100 pmol/ μ l)
 - 2 μ l 10x PNK-Buffer (NEB)
 - 15 μ l dH₂O
 - 1 μ l T4-Polynucleotide Kinase (100 u/ μ l; NEB)
2. Incubate 90 min at room temperature
3. Incubate at 75 °C, in a beaker with water for 10 min, in order to denature wrong complementarities and to inactivate T4-polynucleotide kinase
4. Allow the beaker with the eppendorf tubes inside to cool down slowly at 4 °C, while stirring all the time. In this way, an optimal hybridization of two complementary strands is achieved
5. Add 180 μ l dH₂O (dilution 1:10).The oligonucleotides are ready for use in ligation

B.2.3.2 Digestion of DNA with Restriction Enzymes

Type II restriction endonucleases allow to molecular biologists to cut DNA at specific sites and thus to ligate two DNA segments (by the enzyme T4-DNA Ligase) that have been cut with the same restriction enzyme. Regarding the restriction enzymes, there are enzymes that cut the DNA resulting to sticky ends or blunt ends. The ends resulting from the digestions with these restriction enzymes have a 5'-phosphate or 3'-OH group, and so they do not require incubation with any kinase before further use. According to the purpose, it is possible to make analytical or preparative reactions.

1. In an eppendorf tube pipette together:

Analytical Reaction	Preparative reaction
χ μ l DNA (200 ng)	χ μ l DNA (20 μg)
2 μ l 10x reaction buffer (+BSA)	10 μ l 10x reaction buffer + BSA
0,5 μ l Enzyme (5U)	2 μ l Enzyme (10U)
Add to 20 μ l dH ₂ O	Add to 100 μ l dH ₂ O

(Negative controls without the enzyme must not be forgotten)

2. Incubate at the right temperature (usually at 37 °C) according to the provider for 1 h or overnight.
3. To control the reaction 100-200ng DNA are loaded on an agarose Gel.

B.2.3.3 Dephosphorylation of 5' ends.

If a plasmid is going to be used as a vector for some DNA-insert, and it is cut in such a way (especially for cases resulting in blunt ends) that a lot of relegation of the

vector will take place, resulting in many false clones, then the vector must be dephosphorylated before the ligation.

1. In a fully digested preparative reaction, (B.2.3.2) add 1 μ l (10U) CIP (NEB: 'calf intestinal alkaline phosphatase) and incubate for 1 h at 37 $^{\circ}$ C.
2. Inactivate the CIP by incubating for 10 min at 75 $^{\circ}$ C. Storage of the sample can be done at -20 $^{\circ}$ C or it can be directly used for a preparative Gel electrophoresis (Gel with big 'wells' in order to isolate then the desired band).

B.2.3.4 Ligation of DNA fragments with the T4-DNA-ligase

The ligation of DNA fragments using T4-DNA-ligase is a key point in the construction of new plasmids. The T4-DNA-Ligase uses ATP to join a free 5'-phosphate group with a free 3'-OH group of two double stranded DNA molecules. This is the way to ligate DNA fragments with sticky or blunt ends. In the second case though (with blunt ends) with less success.

The concentration of the vector (dephosphorylated) and the insert, can be easily estimated with an Agarose Gel (B.2.1.2). In the ligation reactions the ratio vector/ DNA insert should be about 1:2 to 1:5.

B.2.3.4.1 Protocol for sticky ends

1. The ligation reactions are prepared according to the table below (always use the vector relegation as a control)

χ μ l DNA-vector(100-300 ng)
 χ μ l DNA-insert (200-1500 ng)
2 μ l 10x T4-DNA Ligase buffer
Add to 19 μ l dH₂O
5 min at 50 $^{\circ}$ C
Cool down at room temperature
add 1 μ l T4-DNA Ligase (400U/ μ l; NEB, for sticky ends)

2. Incubate over night at 12-14 $^{\circ}$ C.
3. 5 μ l from each ligation reaction are loaded on an agarose gel just to control the ligation. The rest is precipitated and prepared for electroporation.

B.2.4 Electrophoresis Methods

B.2.4.1 Agarose Gel

The Gel electrophoresis is the most easy and effective method for separating DNA molecules of different sizes. The principle of the method is based on the fact that a charged molecule will move when placed in an electric field. The speed (u) depends on the charge of the molecule (z), the intensity of electric field (E), and the coefficient of friction (f).

$$U = \frac{Ez}{f}$$

The coefficient of friction depends on the mass and shape of the molecule (circular or linear DNA) and the viscosity of the medium (agarose). Small molecules move faster than larger molecules. More specifically, the method includes the preparation of various agarose gels (% w/v) depending on the expected size of the DNA molecules to be electrophorated. For molecules > 1kb an agarose gel of 0,8% is enough, while for molecules <1kb a 2% agarose gel is needed. In the gel we add a small quantity of ethidium bromide (EtBr), a substance that binds strongly to the double-stranded DNA and has the ability to emit an orange color when it is viewed under the ultraviolet light. The length of the DNA sample can be accurately estimated by comparing the bands with a DNA of a known length (1 kb DNA Ladder). The process of making 100 ml (e.g. 0.8%) agarose gel is summarized below:

- 0,8 g agarose (LE Agarose, Biozym)
- 100 ml TBE buffer
- Heat in order agarose to dissolve
- 5 µl EtBr (5 µl/100 ml)
- stirring

When the mixture has cooled down, it is poured into a special device that will give the right shape to gel. Samples are loaded in the wells, after adding the 6x Gel Loading buffer. Samples are allowed to run at 80-130 volt power for 1h or more, always depending on the length of the DNA.

B.2.4.2 Analytical Agarose Gel

For an analytical agarose gel we used agarose gels with small 'wells' (4mm). The DNA is mixed with an appropriate amount of gel loading buffer, and then loaded into the wells and allowed to run at low voltage for at least 1h.

B.2.4.3 Preparative Agarose Gel

For a preparative agarose gel, are used agarose gels with big 'wells' (22mm). A preparative reaction (B.2.3.2) is loaded into the big wells (1-4), so that it could be then easily to cut out the desired band without the risk of contamination from undigested DNA or other unwanted bands. In addition, in order to reduce the risk of contamination from previous runs, it is advised to clean the device before use, as well as adding new 1x TBE buffer. Using a clean scalpel, the desired band is cut out under the ultraviolet light. Attention and rapid movements are required to limit prolonged exposure of the DNA under the UV light, avoiding thus the formation of thymine dimmers. To minimize DNA mutations, one is strongly advised to adjust the UV device (312nm) at 70%. The isolated piece of agarose can be then used in electro-elution to gain the desired DNA out of it.

B.2.4.4 Electro elution of DNA fragments

The electro-elution is an efficient and DNA size-independent method for isolating DNA from agarose pieces. The disadvantage lies in the fact that it is a quite time consuming method. The procedure is described below:

1. A Dialysis bag (6-10 cm) that has been boiled 2 times in a 10 mM EDTA, pH=8 solution, is washed initially with some H₂O. One of the sides is clammed so that the content cannot escape.
2. The agarose piece that has been excised from the gel is being inserted in the bag. 1-2 ml 1x TBE buffer is added. The other end is also secured. Always avoid bubbles in the bag and try to put the agarose piece as closely to the one side of the bag as possible.
3. The dialysis bag is then placed horizontally on an agarose gel electrophoresis device and 1x TBE buffer is added as well.
4. Let it run for about 1h at 80-100 volt.
5. Under the UV light (70%) testify, if the DNA has been eluted out of the agarose piece. The polarity is then changed for 30 sec, so that the DNA can come off the bag walls.
6. The Dialysis bag is opened carefully from one side and the content is transferred in a clean eppendorf tube.
7. A brief centrifugation is advised in order to precipitate any agarose little pieces.
8. The supernatant is collected in a new eppendorf tube and it can be used directly for ligation or it can be cleaned with phenol/chloroform.
9. A small amount of the supernatant is often loaded on an analytical gel electrophoresis in order to estimate its purity and concentration.

B.2.5 Precipitation, concentration and phenol/chloroform cleaning of DNA

Many times in molecular biology is required the concentration or removal of annoying substances such as: salts from a solution of DNA. In this case the choice is precipitation with ethanol or isopropanol. Should be needed a high purity DNA free of proteins such as histones, then cleaning with phenol-chloroform is the choice.

B.2.5.1 Ethanol precipitation protocol

1. Add 1/10 of the sample volume 3 M sodium acetate pH=5,5 and 3 volumes 100% cold (-20 °C) ethanol
2. Incubate at least for 1h at -80 °C
3. Centrifuge at 13000 rpm for 15-20 min in a cooling centrifuge 4 °C
4. The supernatant is thrown away and same volume of cold 70% ethanol is added to wash the pellet
5. Centrifuge at 13000 rpm for 15-20 min in a cooling centrifuge 4 °C
6. Throw away the supernatant (Note: Pellet can be washed more than once)
7. Dry the pellet and re-suspend it in 20 µl dH₂O

B.2.5.2 Protocol for precipitation of ligation reactions

1. To inactivate T4-DNA-ligase (B.2.3.4.1), incubate at 65 °C for 15 min
2. Add to 50 µl dH₂O
3. Add 5 µl of 3 M pH=5,5 sodium acetate as well as 1 µl tRNA (1 µg/µl) to increase the nucleic acid concentration
4. add 150 µl 100% cold (-20 °C) ethanol
5. Incubate for at least 1h at -80 °C
6. Centrifuge at 13000 rpm for 15-20 min in a cooling centrifuge 4 °C
7. Throw away the supernatant and add 200 µl cold 70% ethanol to wash the pellet
8. Centrifuge at 13000 rpm for 15-20 min in a cooling centrifuge 4 °C
9. Throw away the supernatant
10. Dry the pellet and re-suspend it in 20 µl dH₂O

To control the ligation reaction and the precipitation is strongly advised to run an analytical gel electrophoresis with 5 µl of each ligation reaction.

B.2.5.3 Phenol/Chloroform cleaning protocol

1. Add the same volume of phenol
2. Centrifuge at 13000 rpm for 15 min in a cooling 4 °C
3. Collect the supernatant in a clean eppendorf tube (Note: leave a small amount of supernatant especially near the two phases line)
4. Add the same volume of chloroform
5. Centrifuge at 13000 rpm for 15 min in a cooling centrifuge at 4 °C
6. Collect the supernatant in a clean eppendorf tube (Note: leave a small amount of supernatant especially near the two phases line)

The collected DNA can be precipitated with ethanol or isopropanol as described above. To precipitate with isopropanol the steps below are followed:

For 1 ml collected supernatant:

1. Add 100 µl sodium acetate 3 M pH=5,5 and 900 µl isopropanol
2. Incubate at least 1h at 4 °C
3. Centrifuge at 13000 rpm for 15-20 min in a cooling centrifuge 4 °C
4. Throw away the supernatant and add 1 ml 70% cold ethanol to wash the pellet
5. Centrifuge at 13000 rpm for 15-20 min in a cooling centrifuge 4 °C
6. Throw away the supernatant
7. Dry the pellet and re-suspend it in 20 µl dH₂O

B.2.6 Bacteria Transformation through electroporation

One of the best and easiest methods to introduce foreign DNA into bacteria is the electroporation. The transformation efficiency is about 10^7 - 10^9 colonies per microgram pUC18. For the electroporation, bacteria free of salts and a salt-free DNA solution is required. The bacteria are put together with the DNA solution in a fresh electroporation cuvette (electrode distance of 0,2 cm, BioRad) and they are exposed to a short electric pulse. This leads to formation of small pores in the bacterial cell membrane, so that they are able to take up exogenous DNA. A key factor for the success of electroporation is to work with solutions and bacteria free of ions. Ions create an electric current in the cuvette which results in sparks and warming that finally 'bake' the bacteria. The device: 'Gene Pulser XCell™ Electroporation System' (Biorad) has been used for the electroporation.

B.2.6.1 Electroporation (*E.coli* XL1-Blue)

1. 100 μ l of competent cells are thawed in ice, and mixed with 15 μ l of the precipitated ligation reaction (B.2.5.2)
2. Keep the electroporation cuvettes and the cells/ligation mixture on ice for 5 min
3. Add the cells/ligation reaction mixture in the cuvette avoiding bubble formation
4. Electroporate using the settings bellow:
 - Voltage: 2,5 kV
 - Capacity: 25 μ F
 - Resistance: 200 Ω

Tc should be between 4-5 msec

5. Add 900 μ l LB-Medium without any antibiotics immediately after electroporation to allow cells to recover. Transfer the cells in a new 15 ml falcon and incubate for 1h at 37 °C at 225 rpm
6. Plate the bacteria on LB-Agar +Amp petri dishes and incubate at 37 °C over night (Plate 10, 100 and 300 μ l of bacteria)
7. The next day count the bacterial clones and estimate the transformation efficiency

Note: Always electroporate the vector religation reaction. The bacterial clones then should be much less on these plates, than on the ligation plates.

B.2.7 Plasmid DNA isolation

B.2.7.1 Plasmid DNA isolation from mini-preps

Plasmid DNA isolation from bacteria on a small scale (mini-preps) is usually combined with an analytical digestion with restriction enzymes (B.2.3.2), due to the rapid results and it is used to identify positive bacterial clones, namely bacterial clones carrying the desired plasmid after electroporation. It is based on alkaline lysis of bacterial cells by Birnboim and Doly (1979). Lysis of the bacterial cells is achieved with a NaOH/SDS solution, that denatures protein molecules and DNAs. After

neutralization with potassium acetate, the double stranded plasmid DNA can re-nature and gain its native supercoiled structure, something that can't happen with the bacterial genomic DNA, which is then precipitated along with other cellular components.

1. A unique bacterial clone is inoculated in 5 ml LB-Medium +Amp and incubated at 37 °C overnight under constant stirring at 225 rpm
2. 1 ml of this culture is transferred into 2 ml eppendorf tubes and centrifuged at 5000 rpm at 4 °C for 5 min. The rest 4 ml are stored at 4 °C in order to inoculate a maxi-prep
3. The supernatant is thrown away and the bacterial pellet is re-suspended in 100 µl S1 buffer which contains RNAase (1/100 diluted)
4. Add 200 µl S2 buffer and mix carefully (not vortexing)
5. Add 150 µl cold (4 °C) S3 buffer, as well as 50 µl chloroform, which pellets better the neutralization buffer. Incubate on ice for 5 min
6. Centrifuge for 15 min at 4 °C at 13000 rpm (insoluble cellular components as well as the genomic DNA are precipitated as a pellet, while the plasmid DNA remains in the supernatant)
7. Transfer the supernatant in a new eppendorf tube and add 1 ml 100% cold ethanol (-20 °C)
8. Centrifugation for 15 min at 4 °C at 13000 rpm
9. Throw away the supernatant and add 1 ml 70% cold ethanol (-20 °C) to wash the pellet (Note: pellet washing can be done more than once)
10. Centrifugation for 15 min at 4 °C at 13000 rpm
11. Throw away the supernatant and dry the pellet.
12. Add 20 µl dH₂O to re-suspend the pellet

5 µl are enough for an analytical digestion with restriction enzymes. The remaining solution can be stored at -20 °C for any future use.

B.2.7.2 Plasmid DNA isolation from maxi-preps

For high purity plasmid DNA in large scale (500 ml culture), bacteria are lysed by alkaline Lysis just as in mini-preps. In this case though, the plasmid DNA is not gained by precipitation with ethanol, but through an anion-exchange column. Columns used: Nucleobond AX 500, Company: Macherey-Nagel.

1. The rest 4 ml from the other day culture are used to inoculate a large scale culture (500 ml).
2. Harvest the bacteria by centrifugation at 4 °C, 5000 rpm, for 15 min
3. Re-suspend the bacterial pellet in 12 ml S1 buffer + RNAase
4. Add 12 ml S2 buffer
5. Add 12 ml S3 buffer
6. Incubate on ice for 5 min
7. Wet the filter and equilibrate the column with 6 ml N2 buffer
8. Load the bacterial lysate into the filter

9. When the whole lysate has been through the column take out the funnel, and wash the column with 32 ml N3 buffer
10. Elute the DNA with 15 ml N5 buffer and collect it in a new 50 ml falcon
11. Precipitate with 11 ml of isopropanol. Centrifuge at 4 °C, 5000 rpm, for about 30 min. Throw away the supernatant
12. Add 5 ml 70% cold ethanol (-20 °C) and centrifuge at 4 °C, 5000 rpm, for 20-25 min
13. Throw away the supernatant and dry the pellet
14. Re-suspend the pellet in 200 µl dH₂O and determine the concentration by spectrophotometer measurement (B.2.1.1). Dilute with dH₂O to adjust to the standard concentration of 1 µg/µl (if it is necessary)
15. The DNA can be stored at -20 °C

B.2.8 Characterization of recombinant plasmids

To characterize potential recombinant plasmids that have been isolated using the above procedures, analytical digestions are carried out. Using bio-informatics (Vector NTI, Invitrogen) it is easy to calculate the fragment lengths resulting after digestion with specific restriction enzymes. An analytical gel electrophoresis confirms the presence or absence of these fragments. Alternatively, samples can be also sent for sequencing in several biotech companies.

B.2.8.1 Plasmid DNA sequencing

The sequencing takes place in the biotechnological company MWG Biotech (Ebersberg) by the Dideoxy-ribonucleotide method of (*Sanger, 1977*). Depending on the plasmid purity and the primer that has been chosen, the sequencer can read approximately 1000 bp. The DNA sample can be pre-mixed with a desired primer, or the company can be asked to use a standard primer. The sequencing results are sent within a few days to the recipient by email. The samples were sent as bellow: 1 µg DNA in 15 µl dH₂O. Samples sent for sequencing: ploxP-MCS-pA (primer: M13uni), pLinker5 (primer: M13uni), pmT/cGi500 (primer: MH15), pL5-cGi500 (primer: M13uni).

B.3 Cell Culture Methods

B.3.1 Cell Trypsinization and passaging

1. The cells are washed 2 times with PBS and then some drops of trypsin are added to them (for 6-well plates/ pro well). The cells are then incubated for 5-10 min at 37 °C and are observed under the microscope to see if they have been detached from the flask
2. Add 2 ml of fresh medium in every well and harvest the solution cells/medium in a new falcon
3. Centrifugation for 5 min at 1000 rpm

B.3.7 Cell fixation and nuclei Hoechst33258 staining

Necessary solutions: *Immuno Fix*: Formaldehyde (3,7%) in PBS

1. Cells are washed 2 times with 3 ml PBS each time
2. Add 2 ml of cold Immuno- Fix and incubate on ice for 10 min
3. Aspirate Immuno-Fix and wash the cells 2 times with 3 ml PBS each time
4. Stop the fixation with 2 ml PBS including 1% BSA and 1 µg/ml Hoechst 33258
5. Lift up coverslips and wash them carefully with dH₂O. Place them with the cells side down, on an object slide on which there is one drop of IMMUMOUNT (Thermo)
6. The Object slides must be kept out of light until the cells are about to be observed under the microscope

B.4 Microscopy

The construct-sensor cGi500 (in the fixed cells) was observed in the YFP channel, as this is brighter, shows fewer background than the CFP channel, and bleaching is less severe at higher wave lengths. As the camera records intensities (= grayscale images), and no color information, one has to assign a certain color table to the image. The YFP channel could have been also color-coded in yellow, but for the overlay with red color-coded images (non Cre-recombined cells) and the Hoechst staining (nuclei), which is blue color-coded, green, is more convenient. To perform the pictures' overlay we used the program ImageJ [Martin Thunemann].

Microscope: Zeiss Axiovert 200

Light Source: Oligochrome (TILL Photonics)

Camera: Qimaging Retiga 2000R

Filter-sets: Nuclei: EX: 340/26 nm, DCLP: 410 nm, LP: 440 nm

YFP: EX: 497/16 nm, DCLP: 516 nm, EM: 535/22 nm

CY3: EX: 543/22 nm, DCLP: 565 nm, EM: 610/75 nm

Software: Live Acquisition (TILL Photonics)

C. Results

Overall View of the Project Strategy

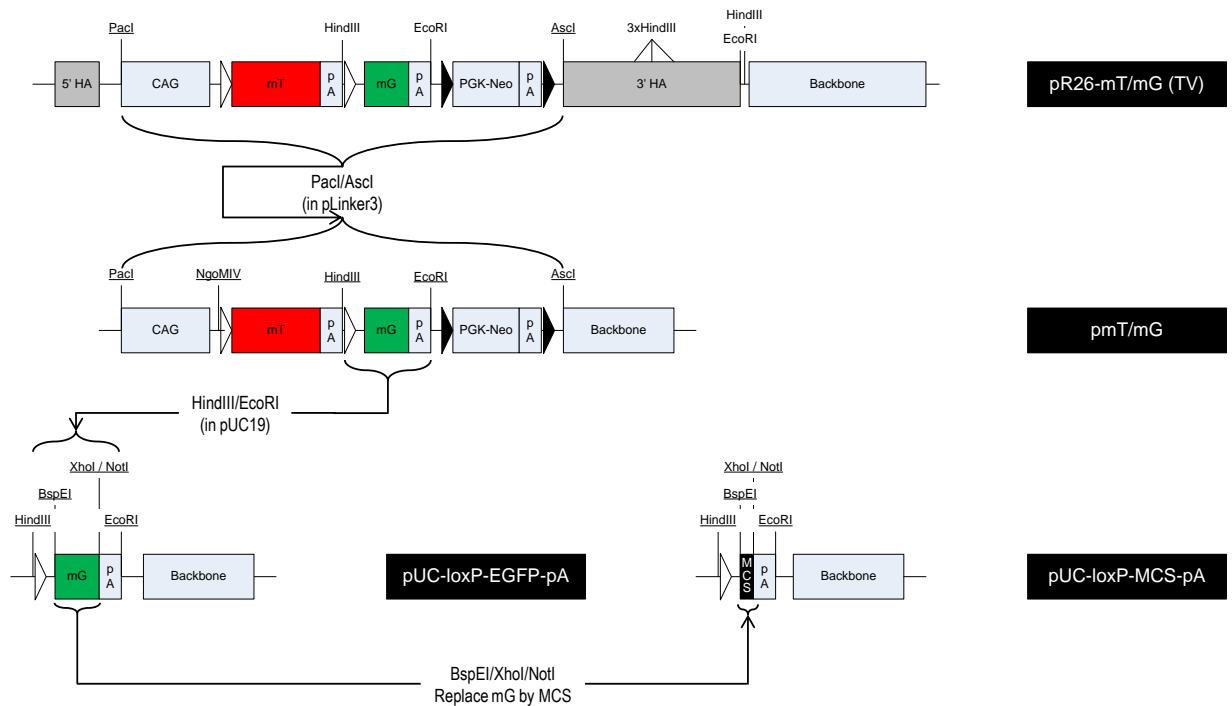

Generation of a pR26-CAG-mT/cGi targeting vector (I)

Picture 13

The above figure shows a schematic representation of the project strategy that was followed. (The figure has been drawn by Martin Thunemann)

The parental targeting vector pR26mT/mG (obtained from: Liqun Luo, PMID 17868096, Addgene plasmid 17787) [1] was initially digested with *Ascl*/*Pacl* producing two fragments: 7,2 kb and 9,8 kb. The 7,2 kb fragment was sub-cloned into the *Ascl*/*Pacl* digested pLinker3 producing a 9,8 kb plasmid, the pmT/mG. From the pmT/mG we excised the **loxP-mG-pA** fragment (1,2 kb) by digestion with *EcoRI*/*HindIII*. This fragment was sub-cloned into *EcoRI*/*HindIII* digested pUC19 producing thus the pUC-loxP-EGFP-pA plasmid (3,8 kb). From the pUC-loxP-EGFP-pA plasmid the **mG (EGFP)** fragment (866 bp) was excised by *Kpn2I*/*XhoI* and replaced by a multiple cloning site (40 bp) coding for the restriction enzyme sites: *FseI*, *XmaI*, *AsiSI*, *MluI*. This plasmid was named pUC-loxP-MCS-pA (3 kb).

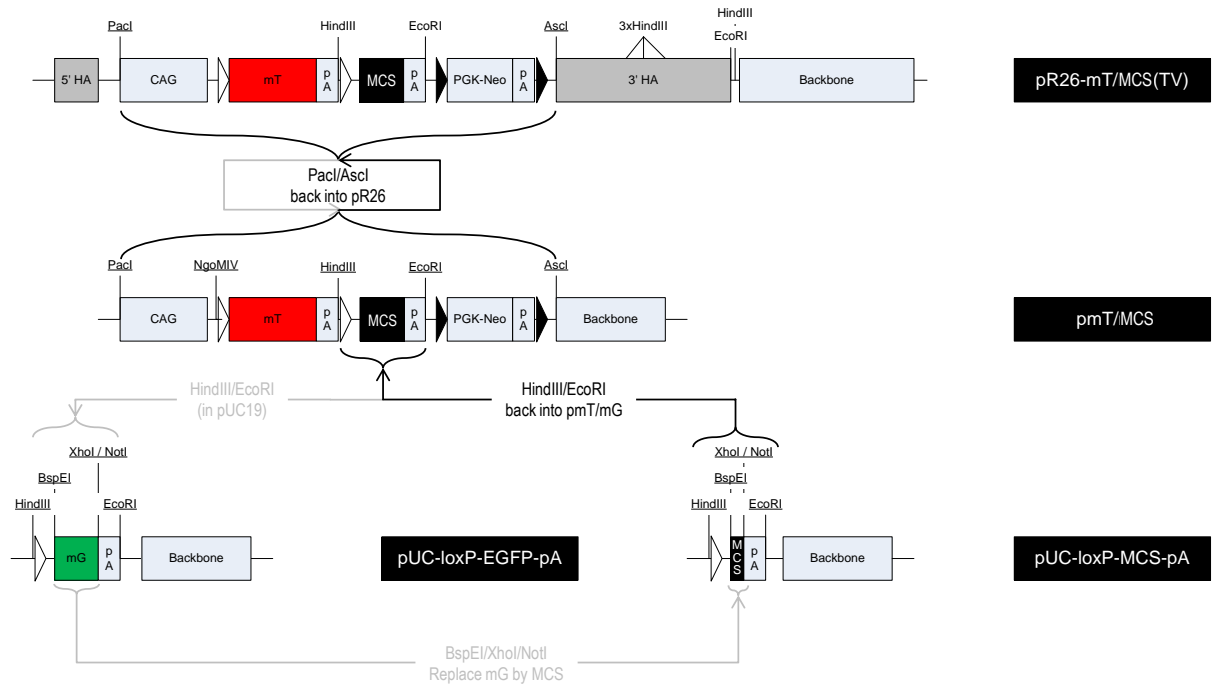

Generation of a pR26-CAG-mT/cGi targeting vector (II)

Picture 14

The above figure shows a schematic representation of the project strategy that was followed. (The figure has been drawn by Martin Thunemann)

The plasmid pUC-loxP-MCS-pA (3 kb) was then digested with *HindIII*/*EcoRI* and the loxP-MCS-pA fragment (369 bp) was sub-cloned back again to the *HindIII*/*EcoRI* digested pmT/mG, producing the pmT/MCS plasmid (9 kb). At that stage, we cloned in the MCS the cGi500 sensor (2264 bp) and the sr39tk (1181 bp) producing the pmT/cGi500 and the pmT/sr39tk plasmids respectively. The last step (which was accomplished by Barbara Birk) involved the sub-cloning of the *Ascl*/*PacI* digested pmT/cGi500 (8,6 kb) and pmT/sr39tk (7,5 kb) back into the *Ascl*/*PacI* digested parental targeting vector pR26mT/mG (9,8 kb) producing thus the targeting vectors pR26mT/cGi500 (18,5 kb) and the pR26mT/sr39tk (17,4 kb).

C.1 Initial materials: pRosa26mT/mG (0,8 µg/µl) and pLinker3 (1 µg/µl).

The parental targeting vector pRosa26mT/mG (17 kb):

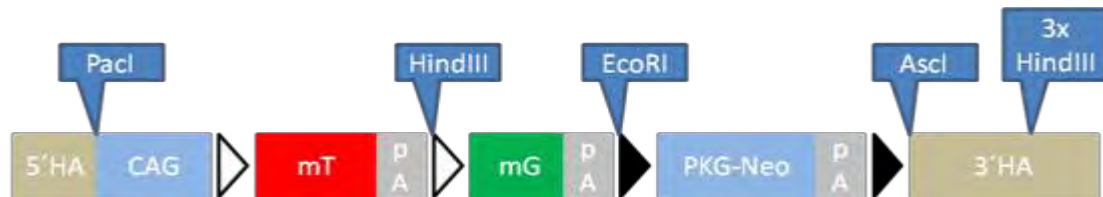

C.2 Construction of the pmT/mG plasmid by sub-cloning of the pRosa26mT/mG (Ascl, Pacl) into the pLinker3 (Ascl, Pacl)

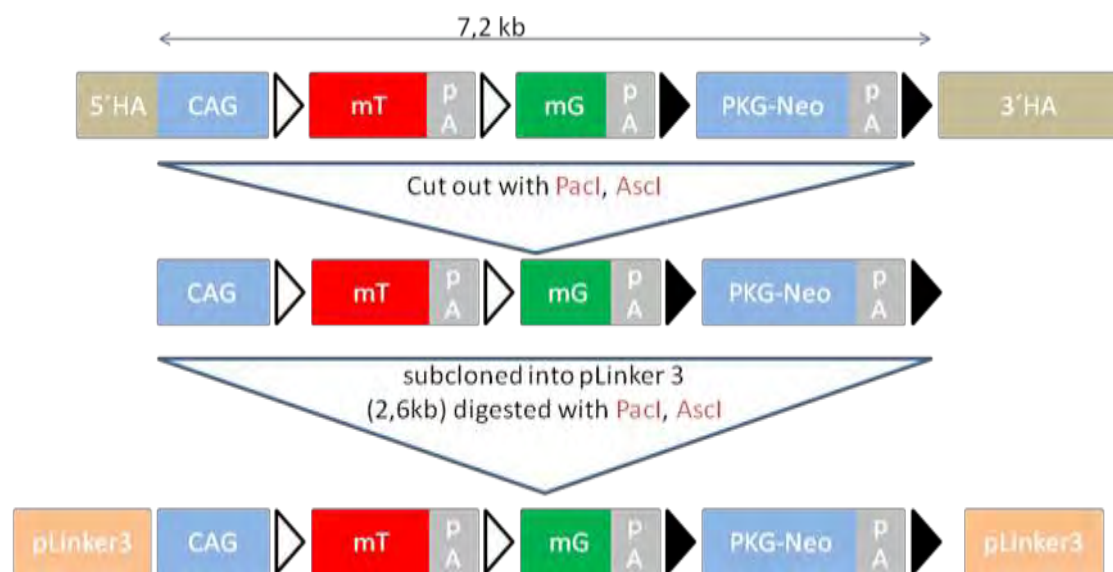

pR26mT /mG
Insert:
7,2 kb

pLinker3
Vector:
2,6 kb

pmT/mG

Picture 15

A schematic figure showing the first cloning step. The 7,2 kb fragment obtained from the parental targeting vector after digestion with *Ascl/Pacl* was sub-cloned into the *Ascl/Pacl* digested pLinker3, producing thus the plasmid pmT/mG (pLinker3 plasmid card as well as all other plasmid cards can be found in the appendix II).

The original plasmid pRosa26mT/mG was too big (17 kb) and therefore difficult to handle it. Additionally, cutting out the mG fragment by *HindIII/EcoRI* would destroy the targeting vector as these enzymes cut also in the homology arms. For this reason the initial step was to sub-clone the pRosa26mT/mG (insert) obtained after digestion with the restriction enzymes *Ascl/Pacl*, into one plasmid specifically constructed for this purpose, the pLinker3 (vector).

20 µg from each plasmid is digested over night with the enzymes: *Ascl/Pacl* according to the provider's instructions. The pR26mT/mG when digested with *Ascl/Pacl*, gives two fragments of 9,8 and 7,2 kb, while the pLinker3: 2,6 kb and 29 bp. In the reaction of pR26mT/mG we add the enzyme *EcoRV* so that the bands can

be better separated (the 9,8 kb band is cut into pieces) in order then to isolate the 7,2 kb band. The 2,6 kb band is needed from the pLinker3 . The vector has been incubated with CIP for 1 h.

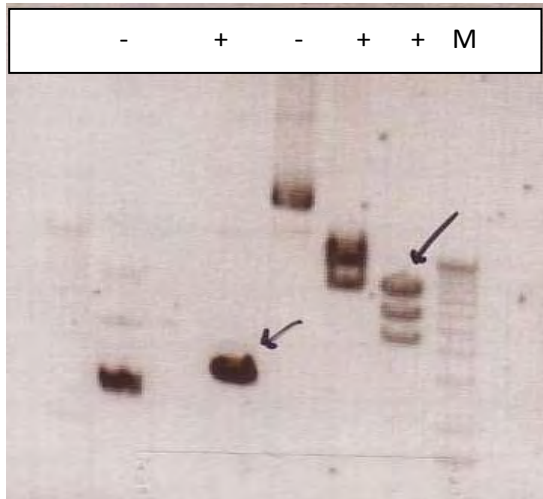

Picture 16

The above picture shows an analytical gel electrophoresis. On the left: digested with *PacI/Ascl* pLinker3 and on the right: digested pR26mT/mG with *Ascl/PacI* and *Ascl/PacI/EcoRV* (the arrows show the bands that need to be electro-eluted).

The reactions were loaded on a preparative gel electrophoresis, from which the desired bands were isolated by electro-elution. After precipitation, an analytical gel electrophoresis was loaded in order to estimate the DNA concentrations and to calculate the vector/insert ratios for the ligation reactions.

M V I



Picture 17

Picture 17 shows an analytical gel electrophoresis after precipitation of the electro-eluates. 1,5 µl out of 30 µl insert and 2 µl out of 40 µl vector have been loaded on the gel.

Ligation Reactions

The ligation reactions ratios were calculated according the above gel shown in picture 2.

Incubation overnight at 10 °C

Vector	0,1 µl	0,5 µl	1 µl	0,5 µl	0,5 µl
Insert	6 µl	6 µl	6 µl	12 µl	

M

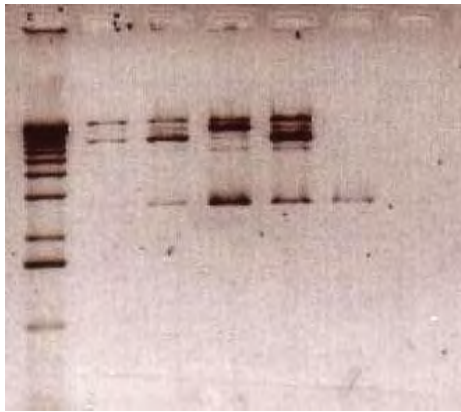

Picture 18

Picture 18 shows the ligation reactions before T4-DNA-ligase inactivation and precipitation (samples were loaded as shown in the table above).

Vector	0,5 µl	0,1 µl	1 µl	0,5 µl	0,5 µl
Insert		6 µl	6 µl	6 µl	12 µl

M

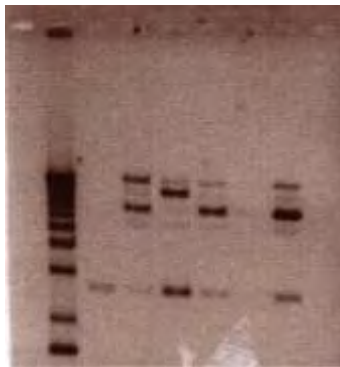

Picture 19

Picture 19 shows the ligation reactions after T4-DNA- ligase inactivation and precipitation (samples were loaded as shown above).

The ligation reactions have been electroporated into bacteria, which were plated on agar plates + Amp. 8 unique clones were inoculated for mini-preps.

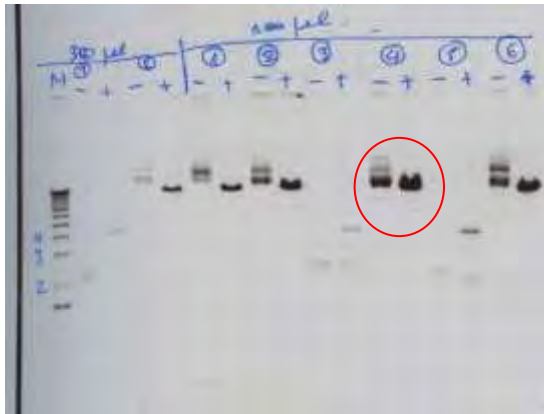

Picture 20

Picture 20 shows an analytical gel electrophoresis with DNA from mini preps digested with *EcoRI*. Digestion of the pmT/mG with *EcoRI* results to one 9,8 kb (linear) band. Clone number 4 (in circle) was inoculated for a 500ml culture (maxi-prep).

C.2.1 Maxi-prep Confirmation

DNA obtained from maxi prep: concentration: 1 $\mu\text{g}/\mu\text{l}$, Volume: 370 μl

M - E A P A+P

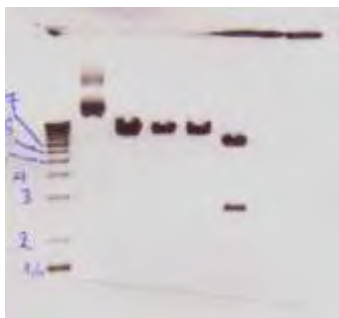

Picture 21

200 ng DNA from the maxi-prep were digested with *Ascl*, *PacI*, *EcoRI*. The pmT/mG plasmid becomes linear (9,8 kb) by *Ascl*, *PacI*, *EcoRI*. While by *Ascl/PacI* results in two 2,8 and 7,2 kb bands.

C.3 Construction of the pUC-loxP-EGFP-pA plasmid

The next step was to excise the mG (loxP-EGFP-pA) from pmT/mG by *HindIII/EcoRI* and to sub-clone it into pUC19.

pmT/mG

loxP-EGFP-pA (insert)

pUC19: vector

pUC-loxP-EGFP-pA

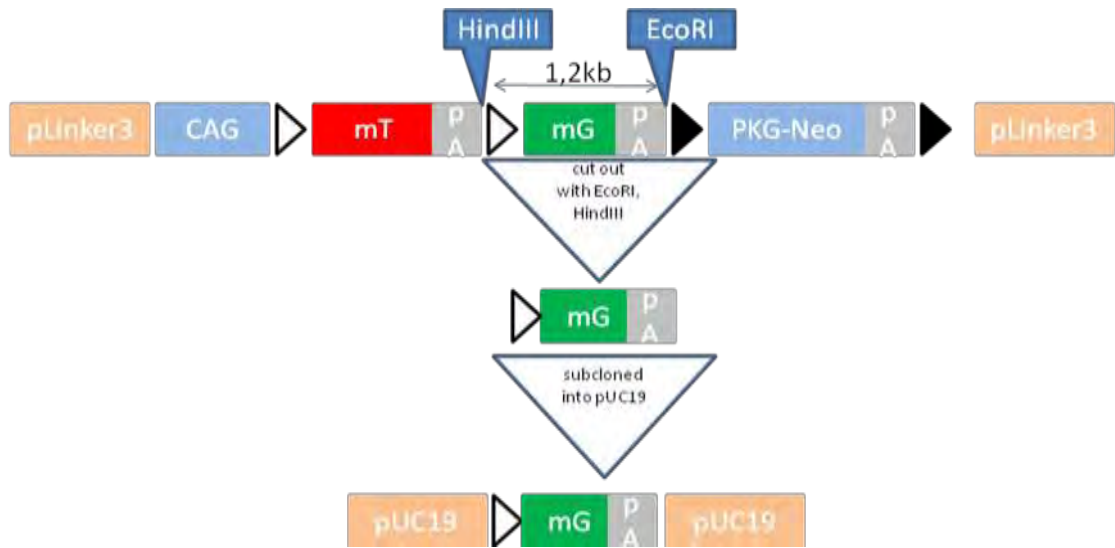

Picture 22

The second step was to excise the mG [loxP-EGFP-pA (1,2 kb)] from pmT/mG by *HindIII/EcoRI* and to sub-clone it into the *HindIII/EcoRI* digested pUC19 (2,6 kb). The plasmid that was generated is the pUC-loxP-EGFP-pA (3,8 kb).

M - E H E+H A+P



← 1,2 kb fragment

Picture 23

The picture above shows the digestion of the pmT/mG by *EcoRI*, *HindIII*, *PacI*, *Ascl*. Digestion with *EcoRI/HindIII* gives two bands: 1,2 and 8,6 kb.

20 µg of pmT/mG and pUC19 were digested over night with *EcoRI/HindIII*.

M - + - +

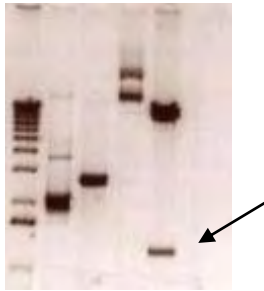

Picture 24

The picture above shows: On the left: digestion of pUC19 with *EcoRI/HindIII* (2,6 kb and 51 bp) and on the right: digestion of pmT/mG with the same enzymes (1,2 kb and 8,6 kb). The arrow indicates the 1,2 kb band that has to be electro-eluted.

The reactions were loaded on a preparative gel electrophoresis and the bands: 2,6 and 1,2 kb were electro-eluted.

M V I M V I

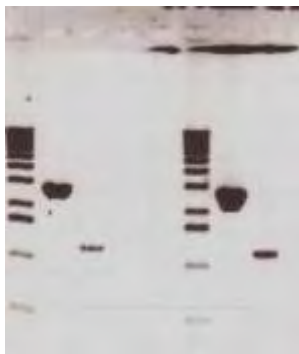

Picture 25

The Picture 25 shows an analytical gel electrophoresis to determine DNA concentration of the electro-eluates. The end volume of the samples was in 30 µl H₂O each. Out of this amount were loaded on the gel: On the left part: 1 µl pUC19 and 1 µl mG. On the right part: 2 µl pUC19 and 2 µl mG.

According to the above results we calculated the ligation reactions:

vector	0,8 µl	0,4 µl	2 µl	0,8 µl		2 µl
insert	8 µl	6 µl	5 µl		5 µl	

The ligation reactions: 0,8:8 0,8 2:5 and 2 were electroporated into bacteria and plated on plates.

M - E E+H - E E+H - E E+H

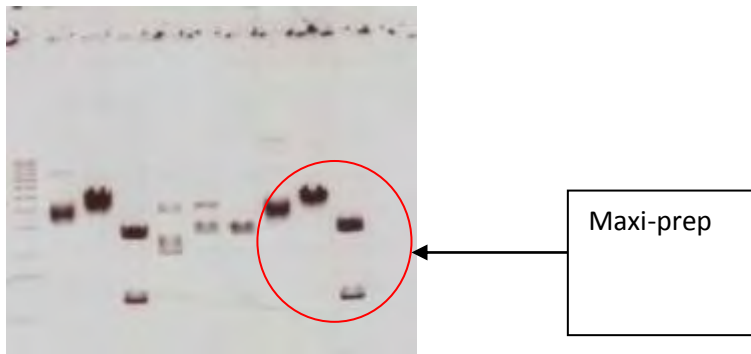

Picture 26

This Picture shows an analytical gel electrophoresis from 3 mini-preps digested with *EcoRI* and *EcoRI/HindIII*. Digestion with *EcoRI* gives a linearized molecule of 3,8kb, while digestion with *EcoRI/HindIII* two bands of 1,2 and 2,6 kb respectively. The clone number 3(indicated by the circle and the arrow) was inoculated for maxi-prep.

C.3.1 Maxi-prep Confirmation

Concentration: 1 µg/µl, Volume: 935 µl

M - E H E+H



Picture 27

The picture above (C.27) shows an analytical gel where samples from the maxi-prep have been loaded. Digestion with: *EcoRI*, *HindIII* and *EcoRI/HindIII*.

C.4 Construction of the pUC-loxP-MCS-pA plasmid

To construct the pUC-loxP-MCS-pA plasmid, the mG fragment (872 bp) was excised out of the pUC-loxP-EGFP-pA plasmid, and it was replaced by a MCS.

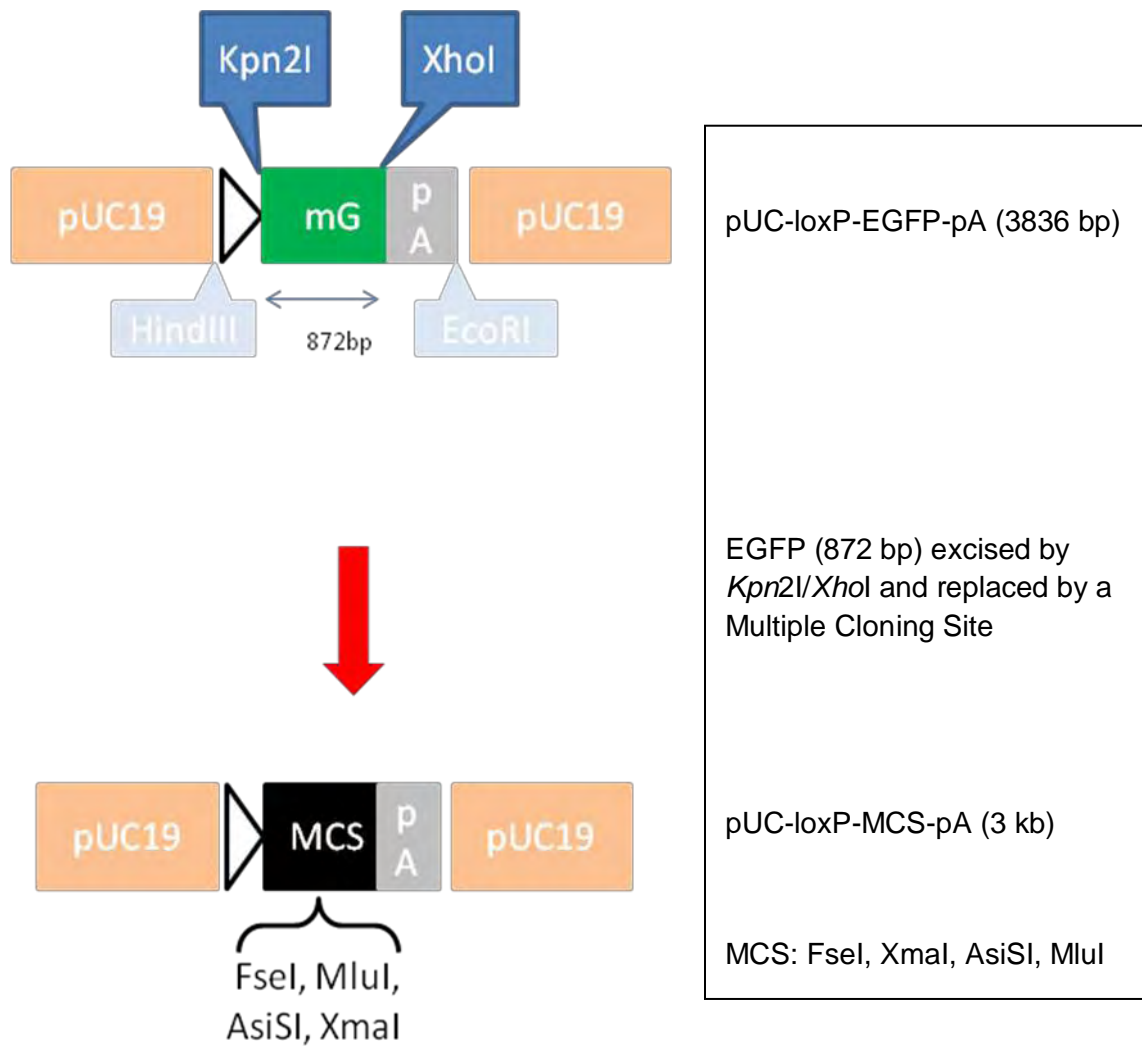

Picture 28

The figure 28 shows the generation of the pUC-loxP-MCS-pA plasmid (3 kb). The 3 kb plasmid remaining after digestion of pUC-loxP-EGFP-pA with *Kpn2I/XhoI* was used as a vector and the MCS oligonucleotides as an insert.

20 µg of pUC-loxP-EGFP-pA were digested overnight with *XhoI* according to the provider's instructions. The next day the reaction was precipitated and digested then with the *Kpn2I* overnight in another reaction buffer.

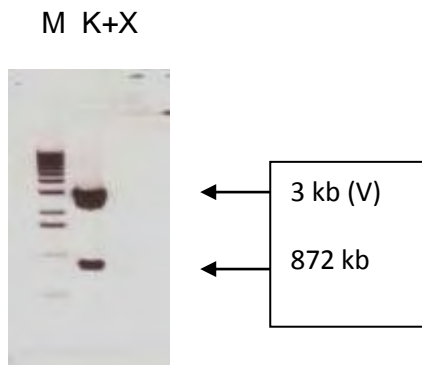

Picture 29

The Picture 29 shows an analytical gel on which it has been loaded 1 µg DNA out of 20 µg. The 3kb band needs to be electro-eluted.

M - E+H K+H E.E

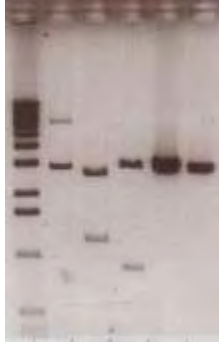

Picture 30

Picture 30 shows an analytical gel on which it has been loaded: pUC-loxP-EGFP-pA (100 ng) digestion with *EcoRI/HindIII*, *Kpn2I/XhoI* as well as 1 µl on the left and 0,5 µl on the right out of 30 µl of the electro-eluates.

According to the above gel, the ligation reactions are calculated:

pUC-loxP-MCS-pA

vector (3kb)	2 µl	2 µl	2 µl
insert (oligos B.1.4.2)	2 µl	0,2 µl	

M R 2:2 2:0,2

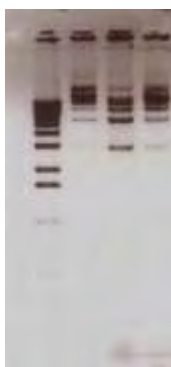

Picture 31

The picture above shows the ligation reactions after the T4-DNA-ligase inactivation and the DNA precipitation.

The ligation reactions were electroporated into bacteria and plated on agar plates. 10 and 100 µl of the electroporation bacteria were plated.

2:0,2 10µl 2:2 100µl
 M -1+1 -2+2 -3+3 -1+1-2+2 -3+3

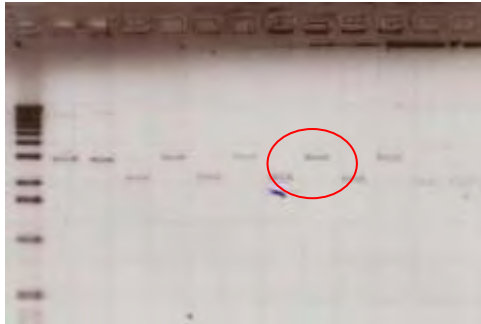

Picture 32

The picture C.32 shows 6 mini-preps from the pUC-loxP-MCS-pA that have been digested with *MluI* (linearized molecule 3 kb). The clone number 1 (2:2, 100 µl) shown in circle was inoculated for maxi prep.

C.4.1 Maxi prep confirmation

Concentration: 1,07 µg/µl , Volume: 190 µl

M - H E

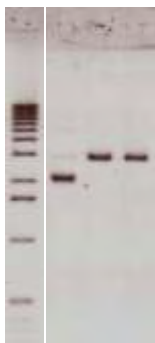

Picture 33

Picture number 33 shows the pUC-loxP-MCS-pA digestion with *EcoRI*, *HindIII*. The molecule is a linearized 3 kb DNA.

C.5 Construction of the pLinker5

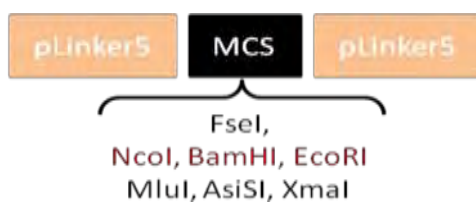

pLinker5 2,6 kb

Vector: pUC19 digested with *EcoRI/HindIII*

Insert: Oligonucleotides for pLinker5

Picture 34

The Picture 34 shows the schematic representation of the pLinker5 (2687 bp). To generate it, pUC19 was digested with *EcoRI/HindIII* and used as a vector for the oligonucleotides (insert).

To sub-clone and multiply the CMV-cGi500 (sensor) and the thymidine kinase CMV-sr39tk it was necessary to construct a vector, based on the pUC19 that will have a cloning site designed so that it will be able to introduce these plasmids and allow an easy handling of them afterwards. The pUC19 was digested with *EcoRI/HindIII* and used as a vector in a ligation reaction and as insert the oligonucleotides (B.1.4.2) that coded for the desired restriction sites. The ligation reactions are:

pLinker5

vector (2,6 kb)	2 µl	2 µl	2 µl
insert (oligos)	2 µl	0,2 µl	

M R 2:2 2:0,2

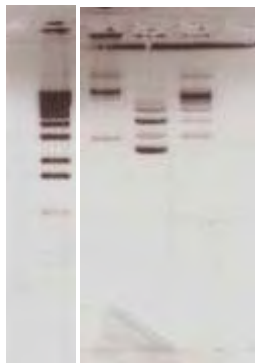

Picture 35

Picture 35 shows the ligation reactions for pLinker5 construction, after the T4-DNA-ligase inactivation and precipitation.

The ligation reactions were electroporated into bacteria and plated on agar plates: 10 and 100 µl.

M -1+1 -2+2 -3+3 -1+1-2+2 -3+3

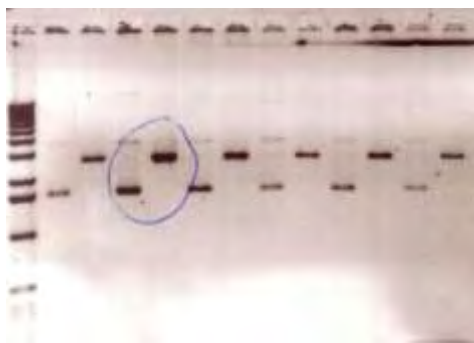

Picture 36

Picture 36 shows 6 mini-preps digested with *NcoI* (linearized molecule 2,6 kb) . On the left part you can see samples from the reaction 2:2, 10 μ l, while on the right 2:0,2, 10 μ l. Clone number 2 (2:2, 10 μ l) was inoculated in a maxi-prep.

C.5.1 Maxi-prep Confirmation

Concentration: 1,1 μ g/ μ l, Volume: 190 μ l

M - B N H

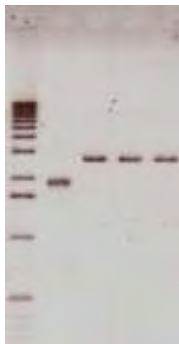

Picture 37

An analytical gel to confirm the maxi-prep. It has been loaded on it: 75 ng pLinker5 digested with *BamHI*, *NcoI*, *HindIII* (linearized DNA 2,67 kb).

C.6 Subcloning of the CMV-cGi500 into pLinker5 (pL5-cGi500)

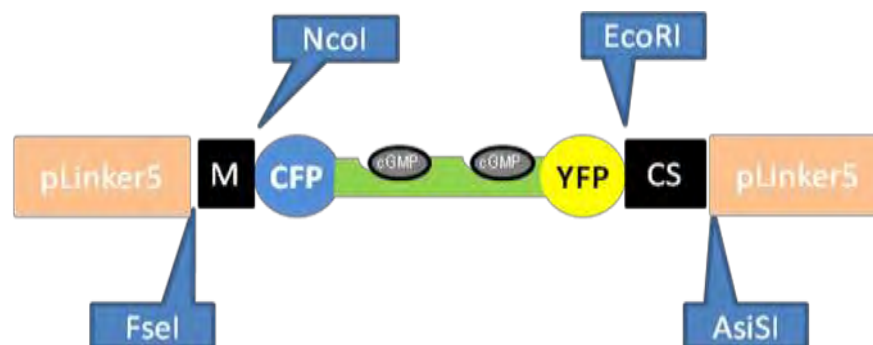

CMV-cGi500 digested with *NcoI/EcoRI*. The 2243 bp band was used as an insert and the pL5 digested with the same enzymes as a vector.

Picture 38

Picture 38 shows the generation of the pL5-cGi500 (4,9 kb).

Taken from the stock (1 μ g/ μ l) CMV-cGi500 (7767 bp). Digestion of 200 ng DNA with the enzymes *NcoI/EcoRI*. The 2243 bp band is the required sensor band. Below you can see the bands resulting when digesting the CMV-cGi500 sensor with *NcoI/EcoRI*.

CMV-cGi500, NcoI/EcoRI

4457 bp
2243 bp ←
505 bp
471 bp
91 bp

M - +

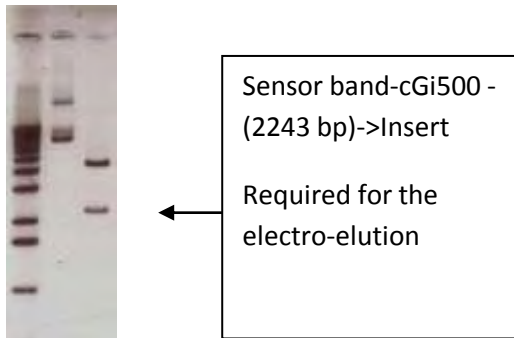

Picture 39

100 ng DNA that has been digested with *NcoI/EcoRI*, was loaded on the gel. The 2243 bp band (indicated by the arrow) is required for the electro-elution.

C.6.1 Preparative Digestions

15 µg of pLinker5 and CMV-cGi500 were incubated overnight with *EcoRI/NcoI*. About 450 ng DNA is shown in the picture below. The pLinker5 was also incubated with CIP.

M

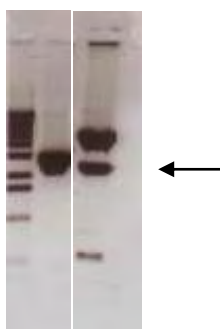

Picture 40

Picture 40 shows the bands resulting from the digestion of pLinker5 and CMV-cGi500 with *EcoRI/NcoI*. On the right: CMV-cGi500 (shown by the arrow), on the left: pLinker 5.

M

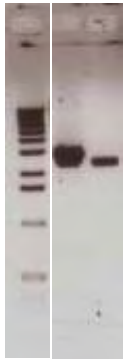

Picture 41

The above picture shows an analytical gel on which it has been loaded: 2 µl out of 20 µl of the electro-eluates .On the left side: pL5, on the right side: cGi500.

Ligation Reactions:

EcoRI/NcoI		
pL5	3	3
cGi500	8	

M R pL5:cGi500



Picture 42

M R pL5:cGi500

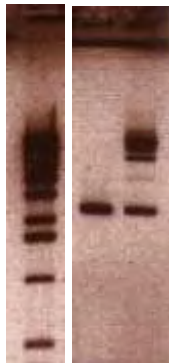

Picture 43

The pictures above show analytical gels on which have been loaded the ligation reactions before (left) and after (right) the T4-DNA-ligase inactivation and precipitation.

M - + - + - + - + - +



Picture 44

M - +



Picture 45

Picture 44 (left) shows the mini-preps of the pL5cGi500, 3:8, 10 µl, digestion with: *EcoRI* (linearized: 4912 bp). Picture 45 (on the right): Clone 3 has also been digested with *EcoRI/HindIII* (1098, 3814 bp). Clone number 3 was inoculated in maxi-prep (shown in circle).

C.6.2 Maxi-prep Confirmation

Concentration: 1034 ng/µl, Volume: 320 µl

M - F N+E F+E



Picture 46

In the picture above it is shown 125 ng DNA of pL5cGi500 that has been digested with: *FseI*, *NcoI*, *EcoRI*. (*FseI*: 4,9 kb, *NcoI/EcoRI*: 2,2 kb 2,7 kb, *FseI/EcoRI*: 2,2 kb 2,7 kb)

C.7 Subcloning of the CMV-sr39tk into pLinker5 (pL5-sr39tk)

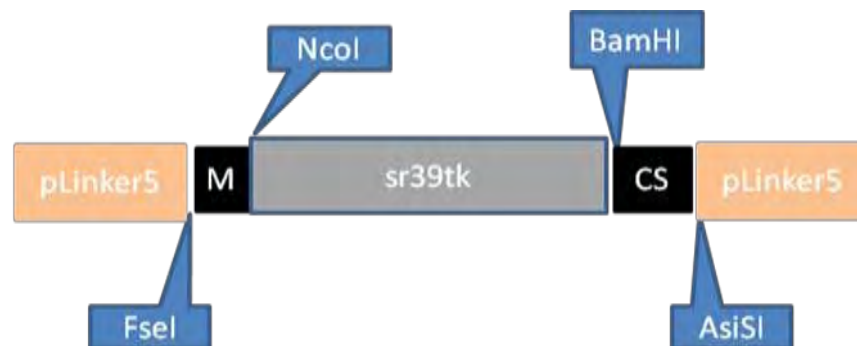

Picture 47

Generation of the pL5-sr39tk (3,8 kb).

Stock (1 µg/µl) CMV-sr39tk (6556 bp). Digestion of 200 ng DNA with the enzymes: *NcoI/BamHI*. The 1154 bp band is the required sr39tk.

CMV-sr39tk, *NcoI/BamHI*

3342 bp
 1154 bp ←
 1032 bp
 735 bp
 293 bp

M - sr39tk

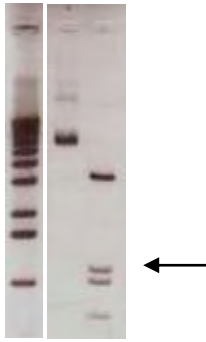

Picture 48

Picture 48 shows 100 ng DNA digested with *NcoI/BamHI* that were loaded on the gel. The 1154 bp band is going to be electro-eluted (arrow).

C.7.1 Preparative Digestions

15 µg of pLinker5 and CMV-sr39tk were digested overnight with *BamHI/NcoI*. The pLinker5 was also incubated with CIP.

M

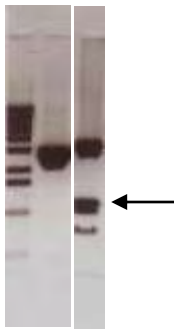

Picture 49

The picture 49 shows an analytical gel on which 450 ng DNA has been loaded. On the right: CMV-sr39tk (indication by the arrow), on the left: pLinker5.

M pL5 tk

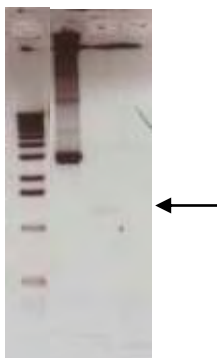

Electro-eluates:
sr39tk (1154 bp)->insert
vector: pL5 (2,6 kb)

Picture 50

The picture 50 shows an analytical gel on which it has been loaded 2 µl out of the 20 µl of the electro-eluates. On the left: pLniker5, on the right: sr39tk.

Ligation Reactions:

BamHI/NcoI		
pL5	3	3
sr39tk	12	

M R pL5:tk

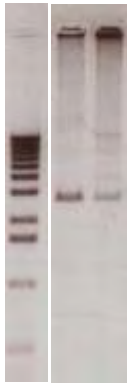

Picture 51

M R pL5:tk

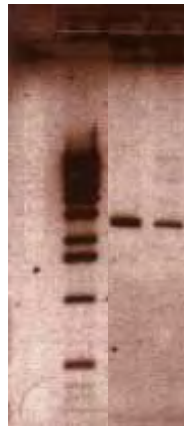

Picture 52

The pictures above show gels of the ligation reactions. On the left before and on the right after T4-DNA-ligase inactivation and precipitation.

M - + - + - + - + - +

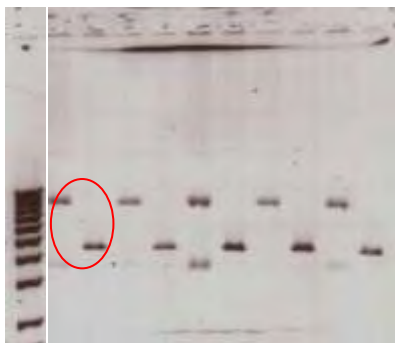

Picture 53

Above are shown the mini-preps of pL5sr39tk, 3:12, 10 µl, digestion with: *EcoRI* (linearized molecule: 3829 bp). Clone 1 (circle) has been inoculated in a maxi-prep.

C.7.2 Maxi-prep confirmation

M -N+B N+M F+B

Maxi-prep Concentration: 1,1 µg/µl Volume: 920 µl

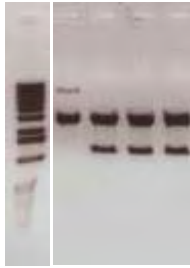

Picture 54

About 125 ng DNA of pL5sr39tk that has been digested with: *FseI*, *NcoI*, *BamHI*, *MluI* is shown above. (*FseI/BamHI*: 2,6 kb 1,2 kb, *NcoI/MluI*: 2,7 kb, 1,1 kb 0,027 kb, *NcoI/BamHI*: 2,6 kb 1,1 kb)

C.8 Construction of the pmT/MCS plasmid

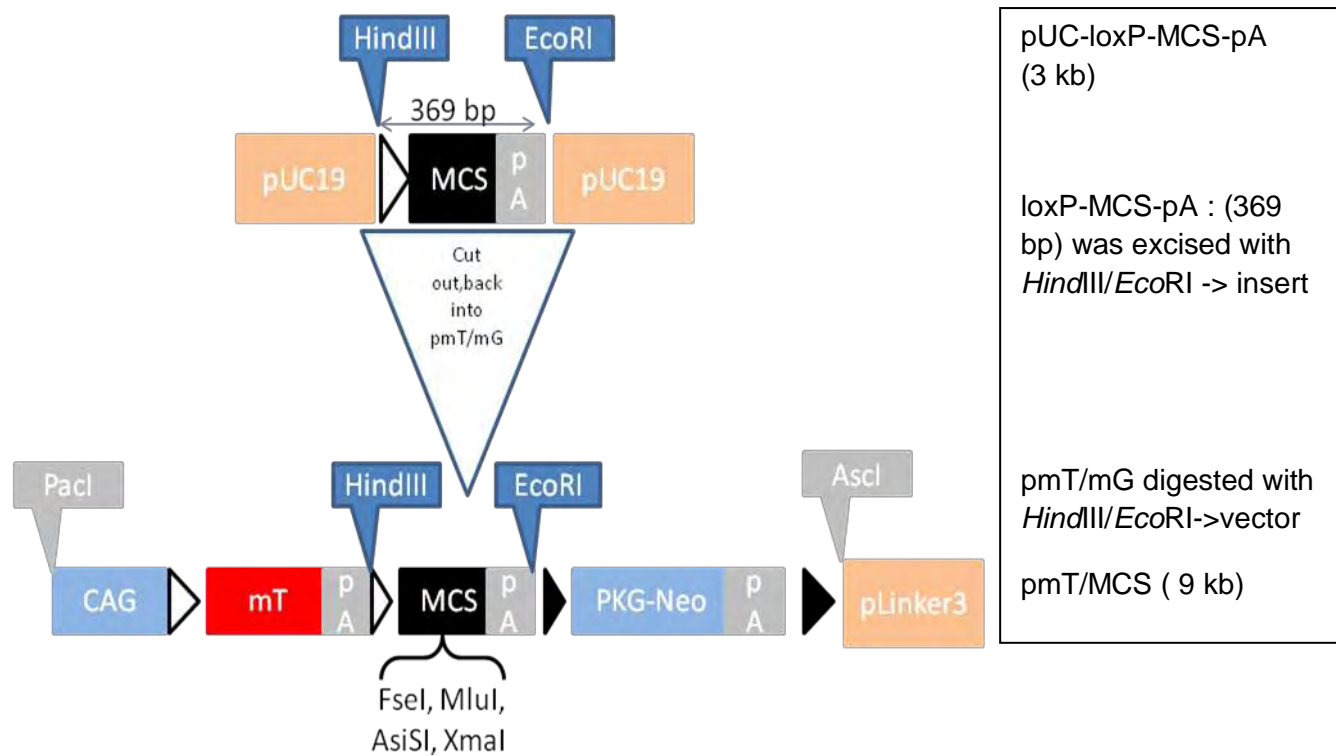

Picture 55

Picture 55 shows the generation of the pmT/MCS (9 kb). The loxP-MCS-pA (369 bp) fragment from the pUC-loxP-MCS-pA (3 kb) was used as an insert. The *HindIII/EcoRI* digested pmT/mG (8683 bp) fragment was used as a vector.

20 µg of pUC-loxP-MCS-pA and pmT/mG were digested with *EcoRI/HindIII* overnight.

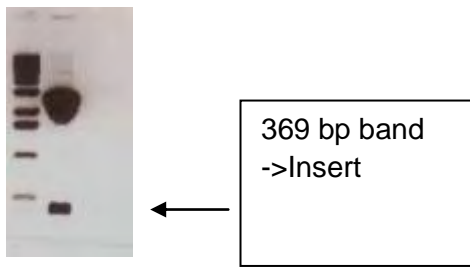

Picture 56

The Picture 56 presents an analytical gel electrophoresis (about 1 µg of pUC-loxP-MCS-pA has been loaded). The 369 bp band is required for the electro-elution (shown by the arrow).

M pmT MCS



Picture 57

4 µl of pmT (8683 bp->vector) and 4 µl of MCS (369 bp->insert) out of the 40 µl of electro-eluates.

Ligation Reactions are being calculated according to the above gel:

EcoRI/HindIII		R
"pmT" (vector)	3µl	3µl
MCS (insert)	6µl	

M R pmT/MCS

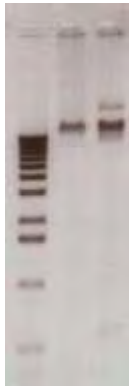

Picture 58

M R pmT/MCS

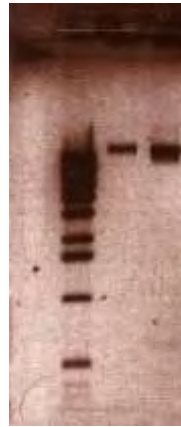

Picture 59

Ligation Reactions (pmT/MCS 3:6) before (on the left) and after (on the right) T4-DNA-ligase inactivation and precipitation.

pmT/MCS, 3:6, 10 μ l

M - + - + - +

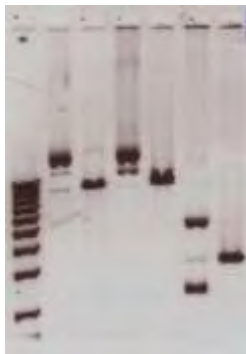

Picture 60

pmT/MCS, 3:6, 100 μ l

M - + - + - +

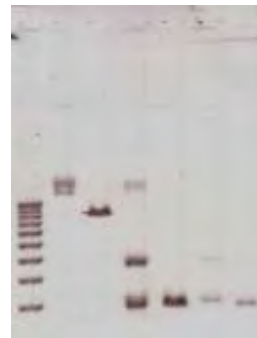

Picture 61

Mini-preps of pmT/MCS digested with *Eco*RI (linearized molecule: 9884 bp).

M -1 +1 -1 +1 -2 +2



← 369 bp

Picture 62

Picture 62: Clones: 1 (pmTMCS, 3:6, 100 µl) and 1,2 (pmTMCS, 3:6, 10 µl) were incubated with *EcoRI/HindIII*. The bands (8683 bp, 369 bp) are shown on picture 62. Clone 1 (pmTMCS, 3:6, 100 µl) was cultured in a maxi-prep (indicated by the circle).

C.8.1 Maxi-prep confirmation

Concentration: 1080 ng/µl, Volume: 210 µl

M - F A+P M

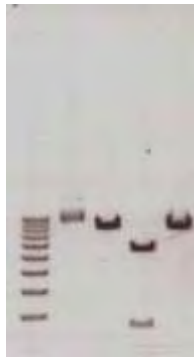

Picture 63

125 ng of pmT/MCS digested with: *FseI*, *MluI*, *PacI*, *AscI* (*FseI*, *MluI*: linearized, 9 kb, *AscI/PacI*: 2,6 and 6,4 kb).

C.9 Subcloning of the pL5-cGi500 into pmT/MCS (pmT/cGi500)

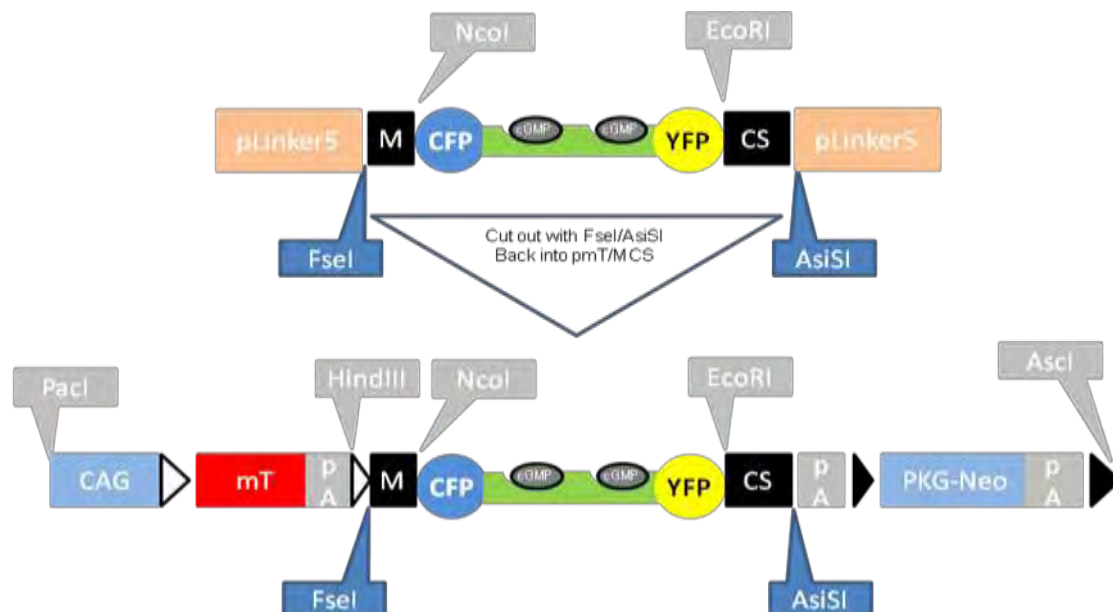

Picture 64

The picture 64 shows the construction of pmT/cGi500 (11297 bp). The plasmid pL5-cGi500 (4,9 kb) was digested with *FseI/AsiSI* and the resulting fragment (2264 bp)->insert, was sub-cloned into pmT/MCS digested with the same enzymes (9033 bp)->vector.

20 µg of pL5-cGi500 and pmT/MCS were incubated overnight with *FseI/AsiSI*. In the reaction of the pL5-cGi500 the enzyme *Asel* is also added in order the excision of the 2264 bp band to become easier.

M cGi500, pmTMCS

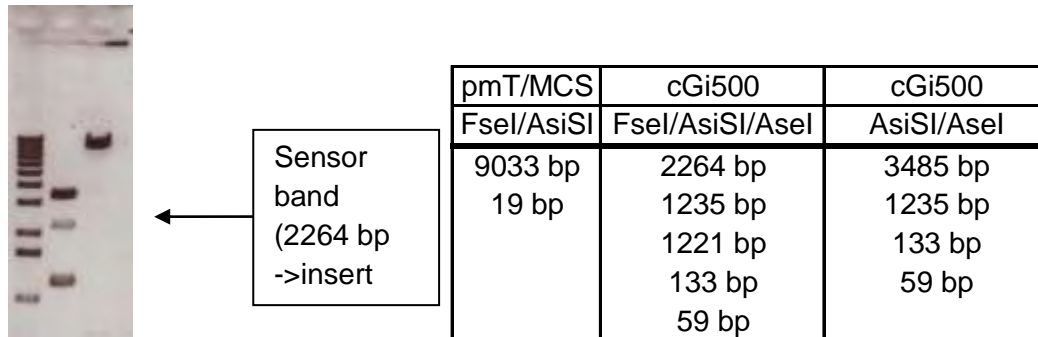

Picture 65

The Picture 65 shows about 200 ng out of the preparative reactions. It can be clearly seen that the *FseI* doesn't cut properly, because a 3,5 kb band appears (cut only with *Asel*, *AsiSI*). The desired band is indicated by the arrow.

M pmTMCS, cGi500

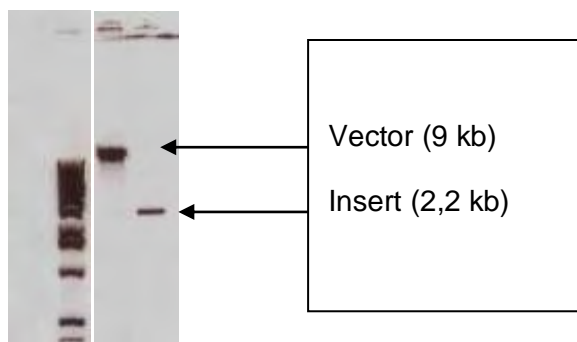

Picture 66

Picture 66 shows an analytical gel after the electro-elution of the desired bands, in order to determine the DNA concentration to calculate the ligation reaction ratios.

Ligation Reactions

FseI/AsiSI		
pmT/MCS	1 µl	1 µl
cGi500	8 µl	

M 1:8 R



Picture 67

Shows the ligation reactions after T4-DNA-ligase inactivation and precipitation. The vector has not been incubated with CIP.

M -1 +1 -2 +2 -3 +3 -4 +4 -5 +5 -6 +6 -7 +7 -8 +8



Picture 68

8 mini-preps of the pmT/cGi500 digested with *Hind*III (1,2 kb and 10 kb) are shown above. Clone number 6 (shown in circle) is the right one. The others could be vector religation as this was not incubated with CIP (aprox.9 kb)

M - H A+P+A



Picture 69

The Picture 69 shows the 6th clone from the above mini-preps which has been additionally digested with *Hind*III (1,2 kb 10 kb), *As*SI/*As*cl/*Pa*cl (6,5 kb 2,1 kb 2,6 kb). This Clone 6 was cultured in a maxi-prep.

C.10 Subcloning of the pL5-sr39tk into pmT/MCS (pmT/sr39tk)

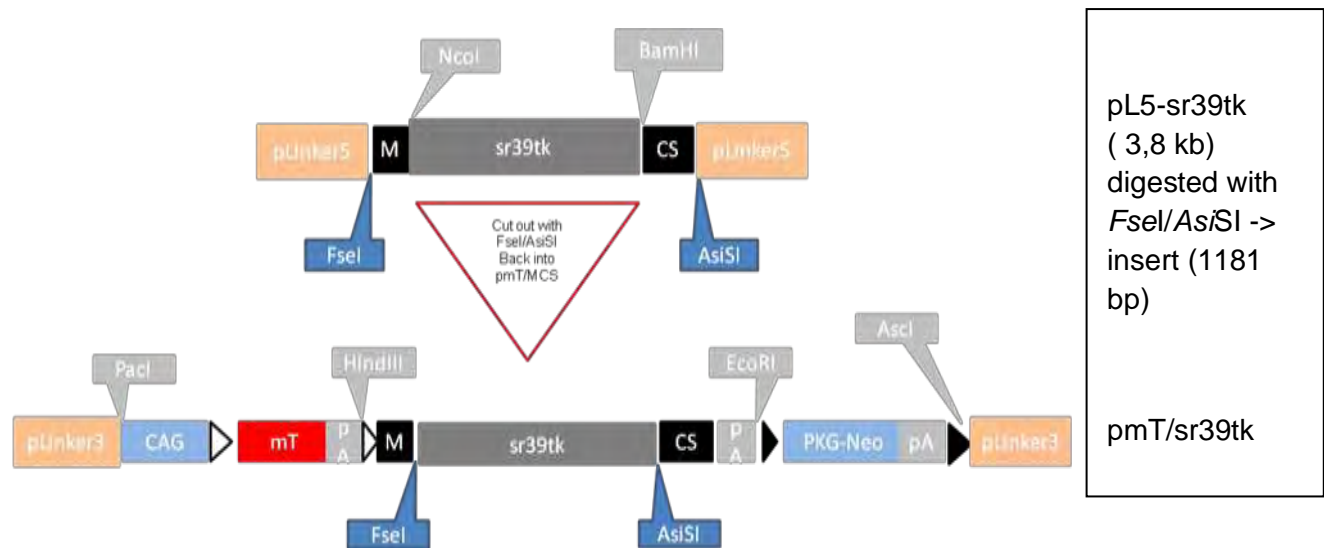

Picture 70

The picture 70 presents the construction of the pmT/sr39tk (10,2 kb). To generate the pmT/sr39tk plasmid, the pL5-sr39tk plasmid was digested with *FseI/AsiSI* (insert) and sub-cloned into *FseI/AsiSI* digested pmT/MCS (vector, 9033 bp)

20 µg of pL5-sr39tk and pmT/MCS were digested overnight with *FseI/AsiSI*.

M I V

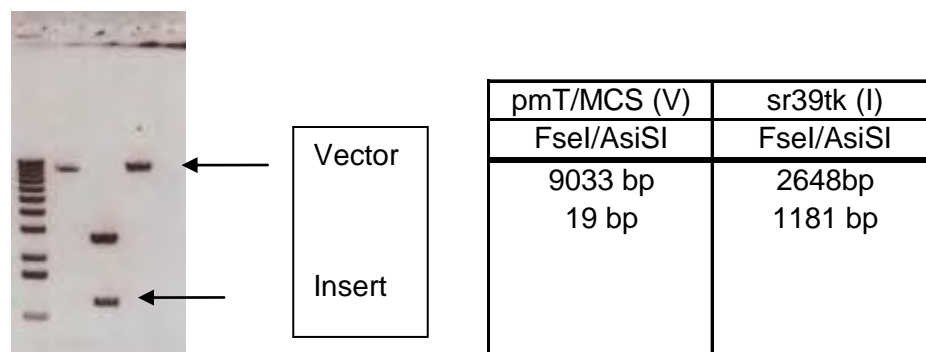

Picture 71

200 ng of pmT/MCS and pL5-sr39tk out of the preparative reactions were loaded on the gel. The 9033 bp band of the pmT/MCS and the 1181 bp band of the sr39tk need to be electro-eluted.



Picture 72

3 μ l out of 60 μ l of the electro-eluate has been loaded on the gel shown above in order to estimate the DNA concentration and the ligation reactions

Ligation Reactions

FseI/AsiSI			R
pmT/MCS(V)	2 μ l	2 μ l	2 μ l
sr39tk(I)	10 μ l	15 μ l	

M R 2:10 2:15



Picture 73

The ligation reactions after T4-DNA-ligase inactivation and precipitation are shown above.

M -1 +1 -2 +2 -3+3 -4 +4 -5 +5 -6 +6-7 +7-8 +8

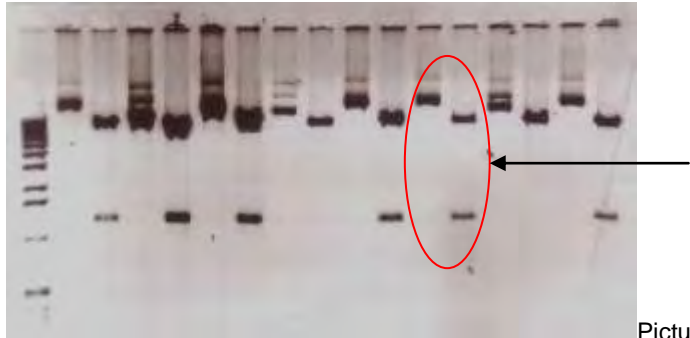

Picture 74

M -9 +9

-16+16



Picture 75

M-17+17

-20+20

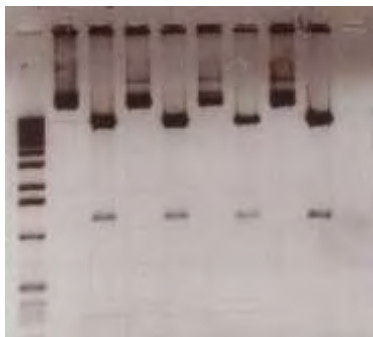

Picture 76

The pictures above 74, 75, and 76 show the mini-preps (1-20) of the pmT/sr39tk digested with *HindIII* (8991 bp and 1223 bp). Clones: 4, 7, 13, 14 and 16 are vector religation. Clone 6 (shown in circle) was inoculated in a maxi-prep.

C.10.1 Maxi-prep confirmation

M - P/F A/F A/P H/A H/P

Concentration: 1437 ng/μl, Volume: 620 μl



pmT/sr39tk				
Fsel/Ascl	Fsel/Pacl	HindIII/Ascl	HindIII/Pacl	Pacl/Ascl
6902bp	5960bp	6820bp	4819bp	7566bp
3312bp	4254bp	2171bp	4172bp	2648bp
		1223bp	1223bp	

Picture 77

200ng of pmT/sr39tk were digested with the enzymes: *Ascl/Fsel*, *Pacl/Fsel*, *HindIII/Pacl*, *HindIII/Ascl*, *Pacl/Ascl*. About 100 ng of the analytical reactions above are shown in the gel.

C.11 Construction of the pR26mT/MCS (targeting vector)

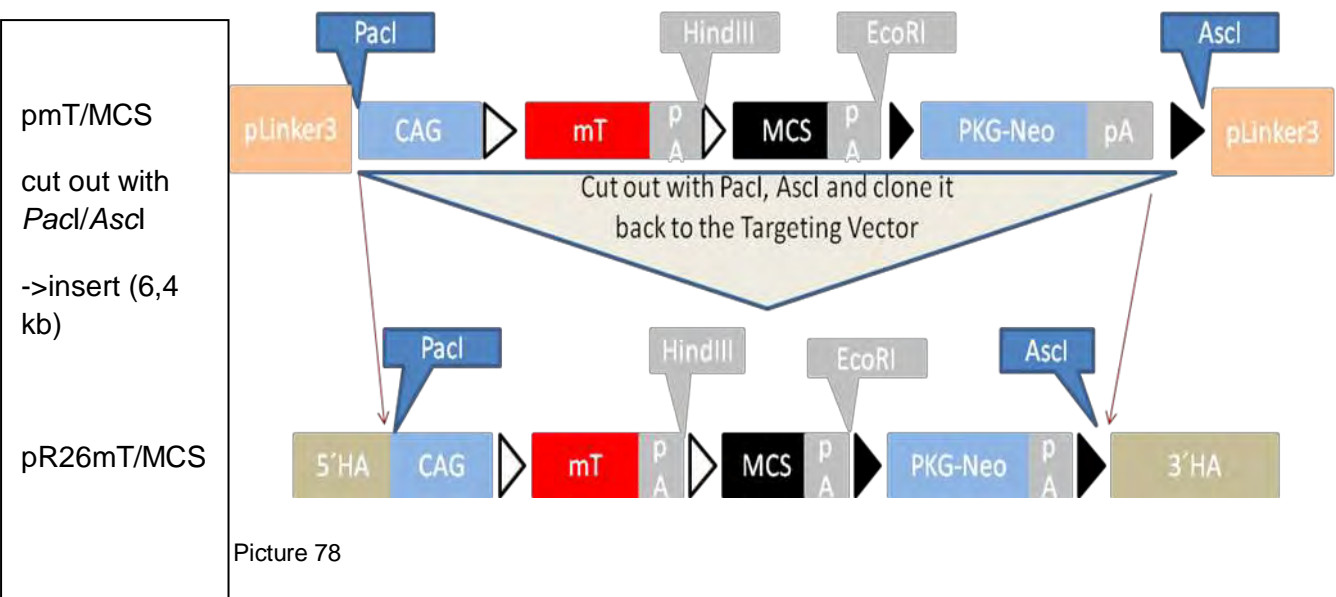

The above picture shows the generation of the targeting vector pR26mT/MCS (16.2 kb) which can be used in order to sub-clone any gene of interest into the MCS. The pmT/MCS was digested with Ascl/Pacl and the 6,4 kb fragment (insert) was cloned back again to the parental targeting vector which was digested with the same enzymes (vector: 9,8 kb).

20µg of pR26mT/mG and pmT/MCS were incubated overnight with Pacl/Ascl.

M I V

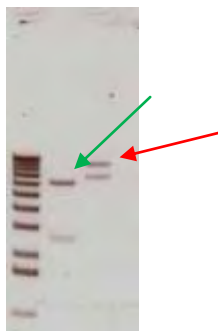

Ascl/Pacl	
pmT/MCS(I)	Rosa26mT/mG(V)
6404 bp	9862 bp
2648 bp	7236 bp

Picture 79

100 ng of the preparative reactions are shown in the picture 79 (the red arrow indicates the **vector**- 9,8 kb while the green one indicates the **insert** 6,4 kb).

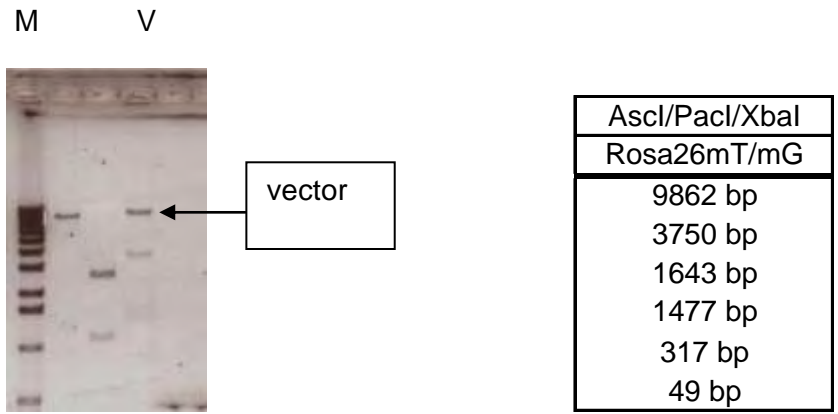

Picture 80

100 ng of the pR26mT/mG. In the reaction the enzyme *XbaI* was also added. The 9,8 kb band needs to be electro-eluted (also incubated with CIP).



Picture 81

Analytical gel to determine the DNA concentration for the ligation reactions. 1 µl DNA out of the 50 µl of the electro-eluates (**vector**, **insert**).

Ligation Reactions

Pacl/Ascl			
pR26mT/mG (V)	4µl	4µl	4µl
pmT/MCS (I)	6µl	8µl	

M 4:6 R

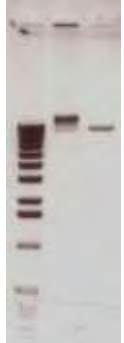

Picture 82

M 4:8 R



Picture 83

Pictures 82, 83: Ligation Reactions after precipitation and T4-DNA-ligase inactivation.

M - + - + - + - + - +

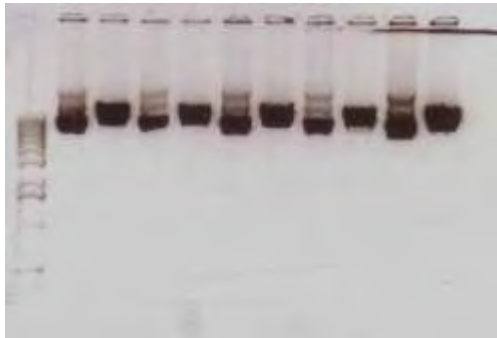

Picture 84

The Picture 84 shows the mini-preps of the 4:6 ligation reaction. Digestion with *NheI/FseI* (12399, 3509, 358 bp). The proper clone does not exist. It is rather only the religation of the insert (pmT/MCS) 9 kb.

M - + - + - + - + - +

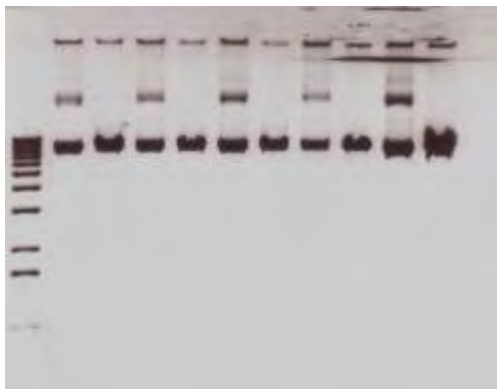

Picture 85

The Picture 85 shows the mini-preps of the 4:6 ligation reaction. Digestion with *EcoRI* (10088, 6178 bp). There is not a proper clone here either.

M - + - + - + - + - + - + - +

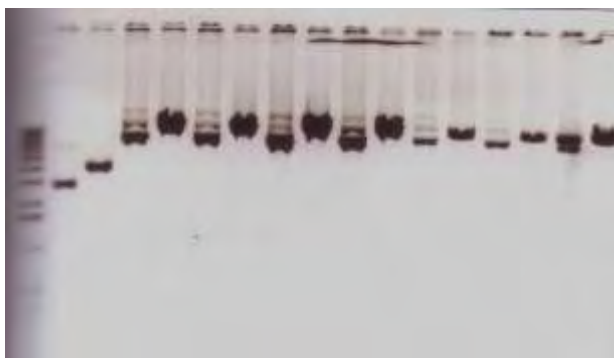

Picture 86

Mini-preps, 4:8, 300 µl, *EcoRI*: 10088, 6178 bp.

M - + - + - + - + - + - + - + - +

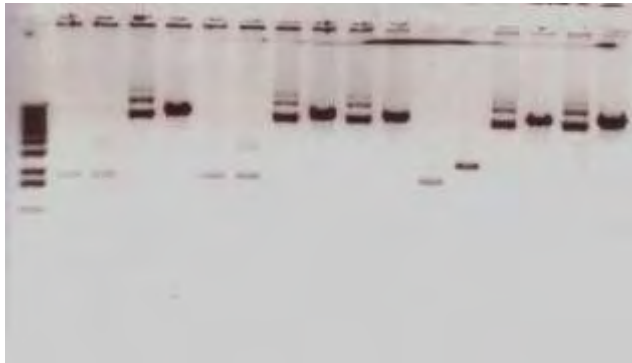

Picture 87

Mini-preps, 4:8, 100 µl, *EcoRI*: 10088, 6178 bp. Unknown region of DNA.

None of the above mini-preps shown in the pictures 84-87 had the proper bacterial clone. Its rather insert religation (9 kb) or/and unknown DNA!

C.12 Construction of the pR26mT/cGi500 (targeting vector)

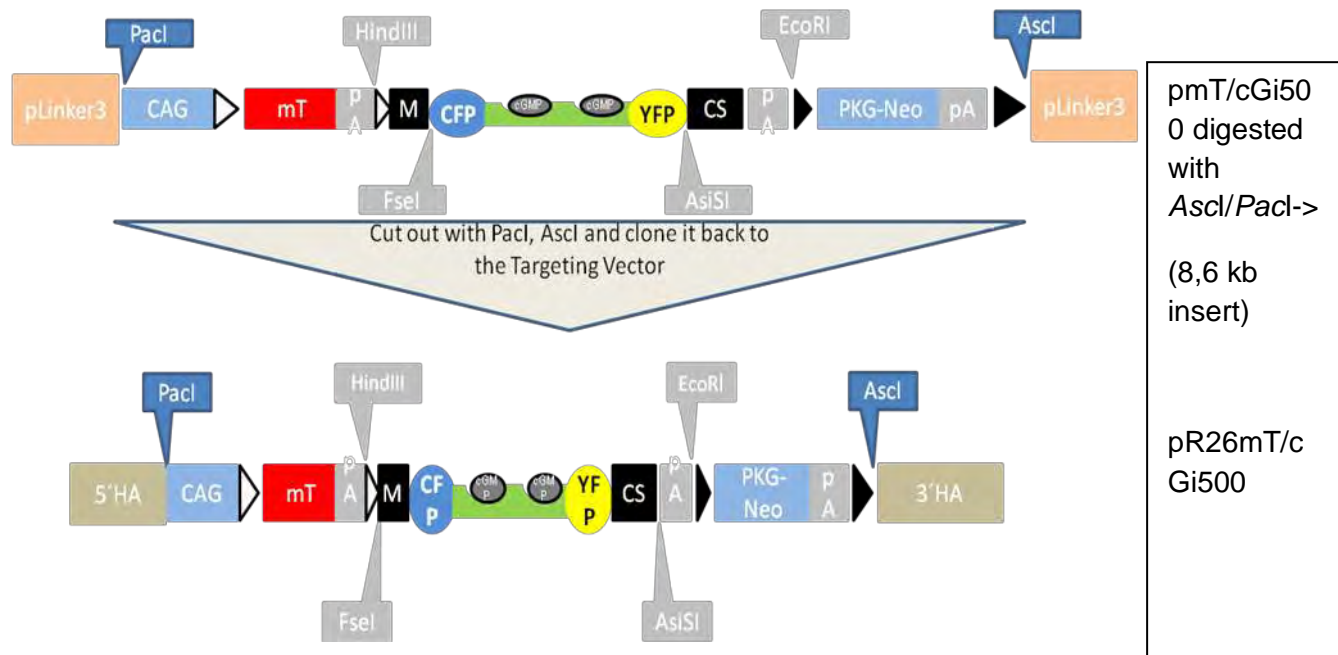

Picture 88

Construction of the targeting vector pR26mT/cGi500 (18,5 kb). To generate the pR26mT/cGi500, the pmT/cGi500 was digested with *Ascl*/*Pacl* (insert: 8,6 kb) and was sub-cloned into *Ascl*/*Pacl* digested pR26mT/mG (vector: 9,8 kb).

16µg of pR26mT/mG and 20 µg of pmT/cGi500 were digested overnight with *PacI*/*Ascl* (+*XbaI*).

pR26mTmG pmTcGi500
 (PacI/Ascl/XbaI) (PacI/Ascl)

M - + - +

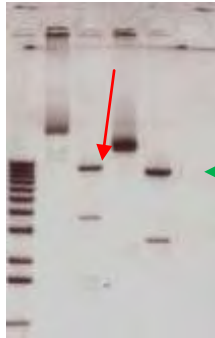

Ascl/PacI
pmTcGi500
8649 bp
2648 bp

Picture 89

200 ng out of the preparative reactions were loaded on this gel. From the insert (pmT/cGi500) the 8,6 kb band is needed while from the vector (pR26mT/mG) the 9,8 kb band (vector, insert are indicated by arrows).

The ligation ratios are calculated according the nanodrop measurements.

PacI/Ascl				
pR26mT/mG (V)	1µl	3µl	1µl	3µl
pmT/cGi500 (I)	6µl	6µl		

R1 1:6 R3 3:6 M

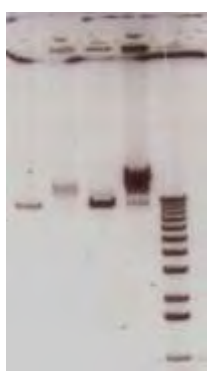

Picture 90

Ligation reactions after T4-DNA-ligase inactivation and precipitation.

M - + - + - + - + - + - + - + M - + - + - + - + - + - + - + - +

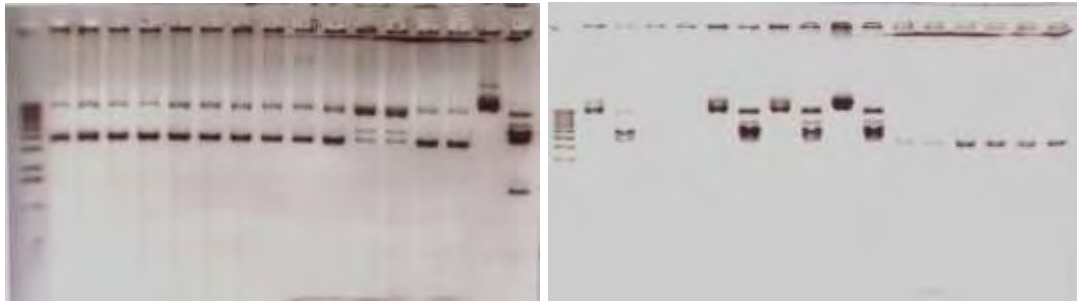

Pictures 91, 92

The pictures above show the mini-preps of the 1:6, 3:6 ligation reactions (pR26mT/cGi500) (digested with *Xba*I: 11554, 5149, 1477, 317 bp). A right clone is not found! The resulting DNA is of unknown origin (pic.91) and some insert religation (pic. 92, 1-5 samples)!

C.13 Cell Culture Results

MEF cells have been transfected with the plasmids bellow:

1. pmT/mG + pUC19
2. pmT/mG + pIC-Cre
3. pmT/cGi500 + pUC19
4. pmT/cGi500 + pIC-Cre

Cells were fixed 2 days after transfection and observed under the microscope. In the 1st case the cells should exhibit red fluorescence as they are co-transfected with pUC19. In the 2nd case pIC-Cre is co-transfected and excises the floxed td Tomato (mT) so that the cells show green fluorescence due to the mG fluorescent protein. In fact Cre recombinase needs some time in order to recombine all successfully transfected cells. This is why 2 days after transfection we observe some red fluorescence in the red channel along with the green fluorescence. But the red background should be much less compared to the 1st case (co transfection with pUC19). In the 3rd case the cells should also express the red fluorescent protein. In the 4th case the td Tomato (mT) is excised by the Cre recombinase just like in case 2. Under the microscope we observe the cGi500 sensor in fixed cells, in the YFP channel as no cGMP is bound on it. The microscope records only grey scale images (intensities) and no color. The image then is color-coded green, as this color enables better overlays with the blue nuclei pictures and the pictures from the red channel. The results of the microscopy are just as expected, revealing the perfect function of the constructs.

C.11.1 Transfection with pmT/mG + pUC19

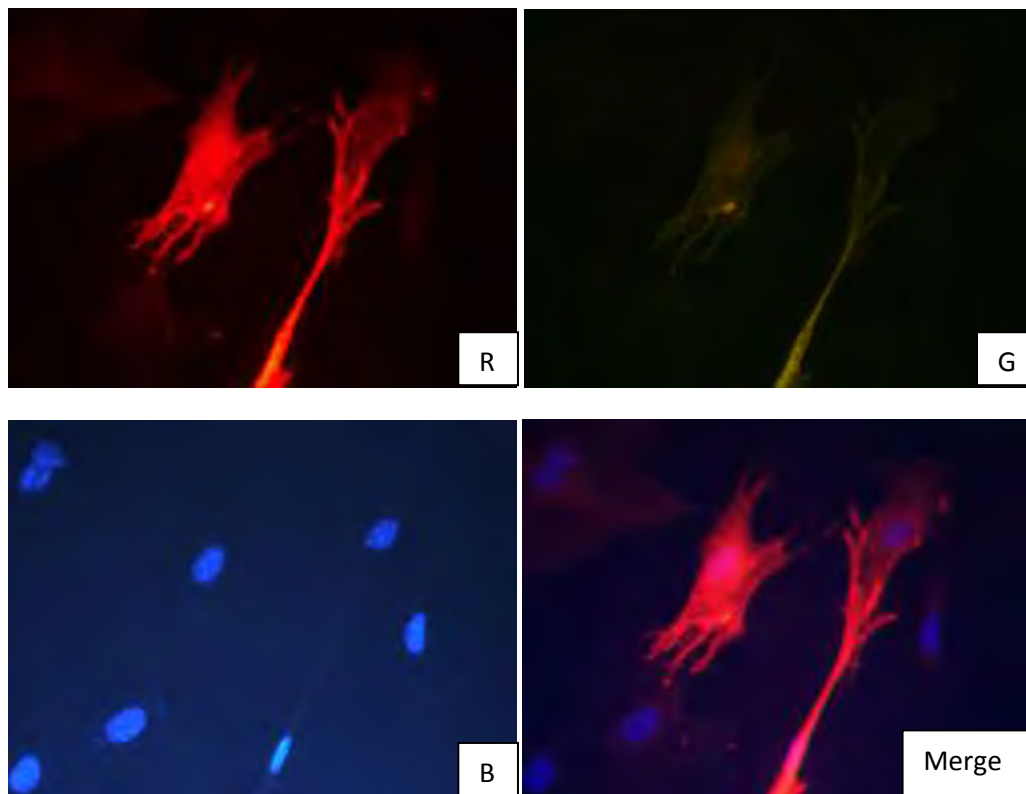

Picture 93

Picture 93 shows the fixed MEF cells transfected with the plasmid pmT/mG and the pUC19. R,G show the cells in the red and green channel respectively while B shows the cells nuclei. Merge is the overlay of the three pictures.

Transfection with pmT/mG + pUC19

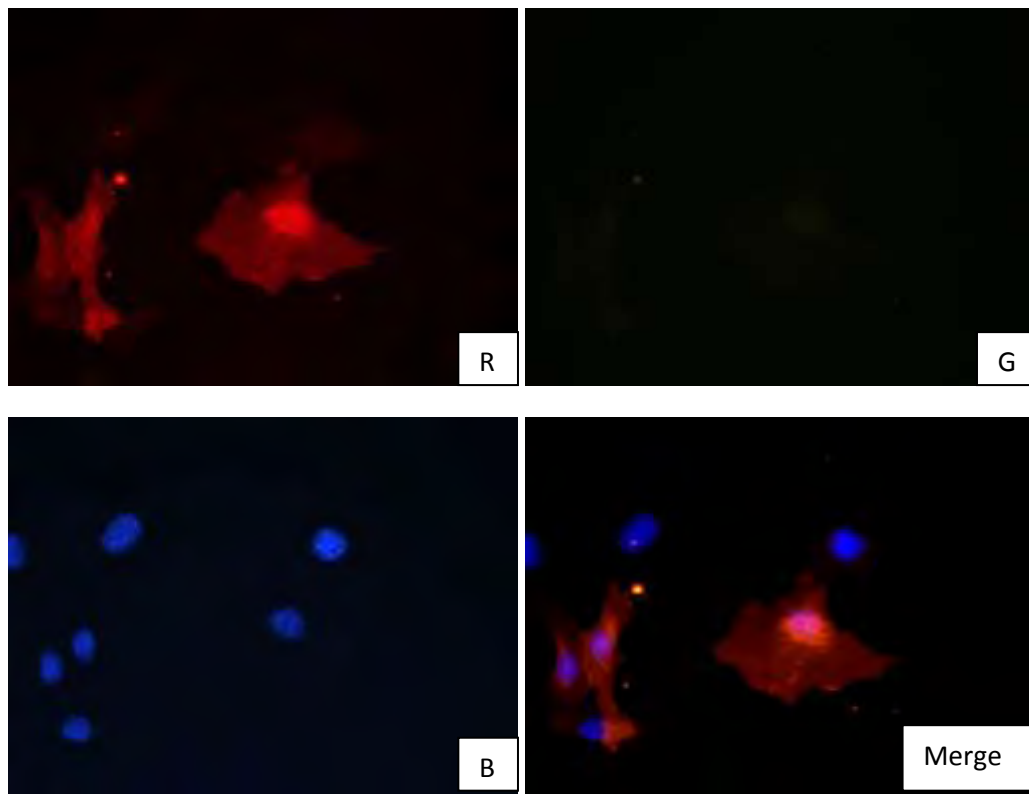

Picture 94

Picture 94 shows the fixed MEF cells transfected with the plasmid pmT/mG and the pUC19. R,G show the cells in the red and green channel respectively while B shows the cells nuclei. Merge is the overlay of the three pictures.

C.11.2 Transfection with pmT/mG + pIC-Cre

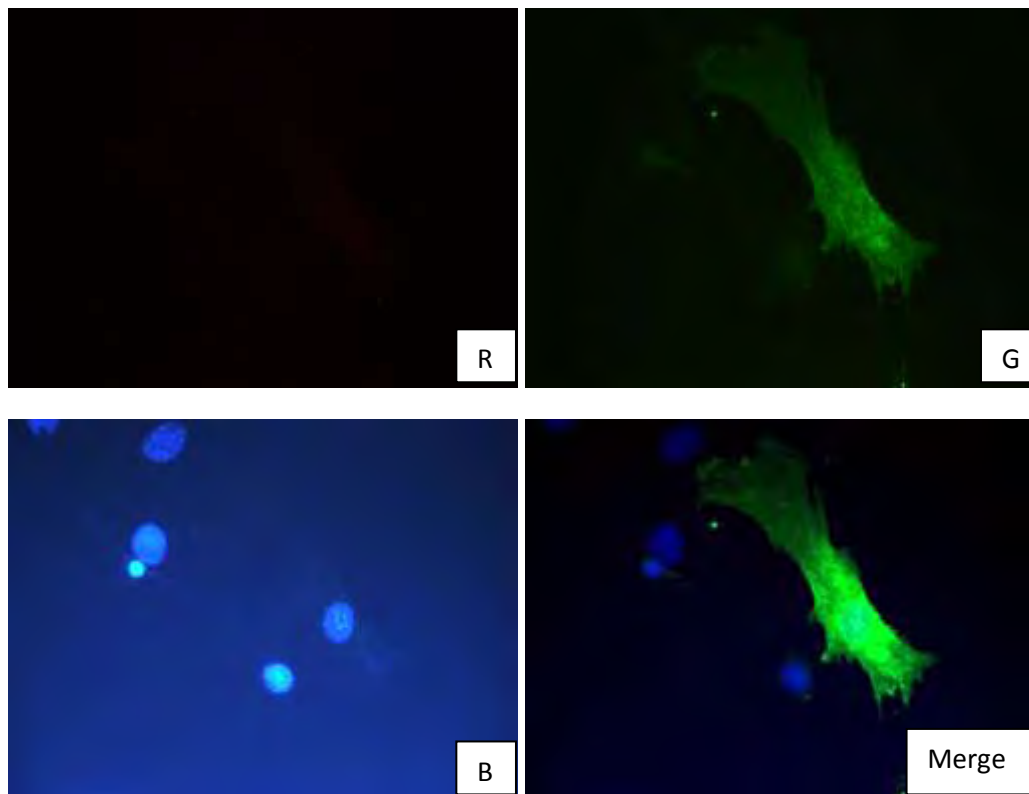

Picture 95

Picture 95 shows the fixed MEF cells transfected with the plasmid pmT/mG and the pIC-Cre. R,G show the cells in the red and green channel respectively while B shows the cells nuclei. Merge is the overlay of the three pictures.

Transfection with pmT/mG + pIC-Cre

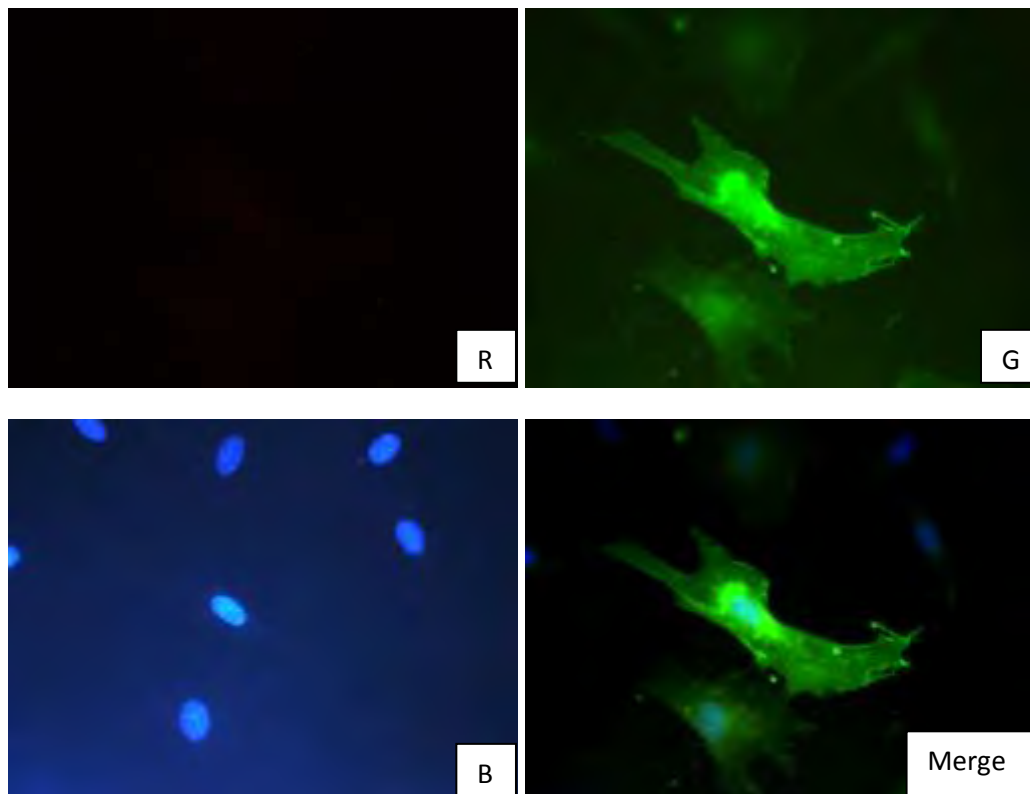

Picture 96

Picture 96 shows the fixed MEF cells transfected with the plasmid pmT/mG and the pIC-Cre. R,G show the cells in the red and green channel respectively while B shows the cells nuclei. Merge is the overlay of the three pictures.

C.11.3 Transfection with pmT/cGi500 + pUC19

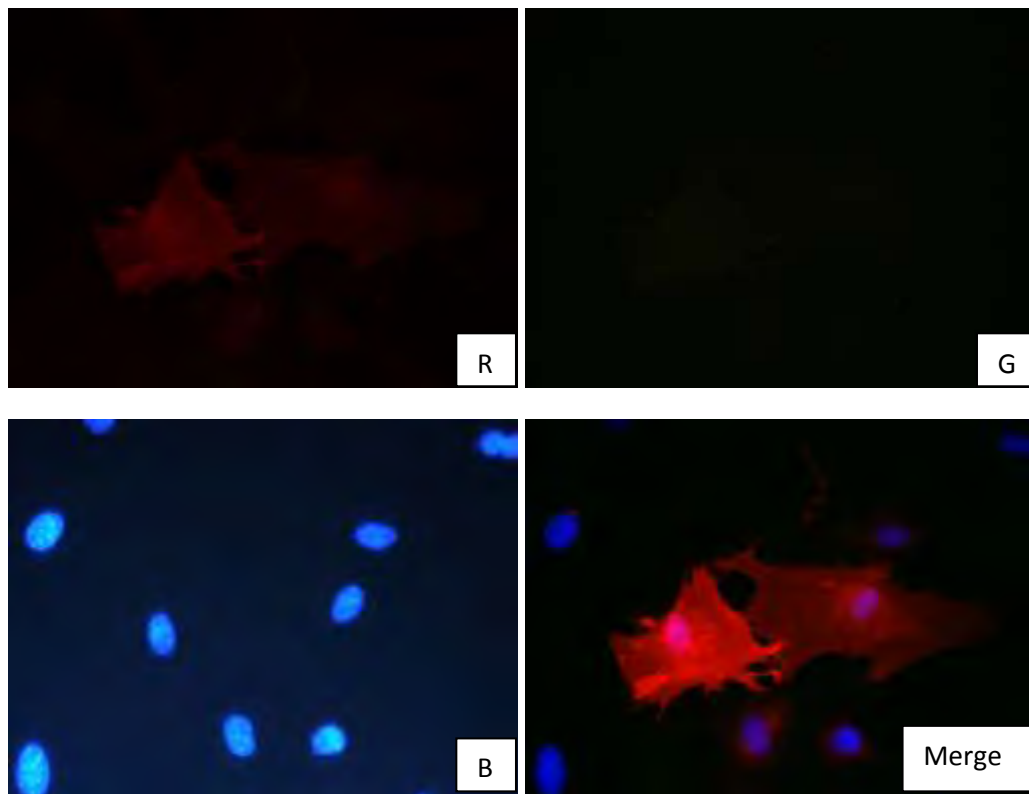

Picture 97

Picture 97 shows the fixed MEF cells transfected with the plasmid pmT/cGi500 and the pUC19. R,G show the cells in the red and green channel respectively while B shows the cells nuclei. Merge is the overlay of the three pictures.

Transfection with pmT/cGi500 + pUC19

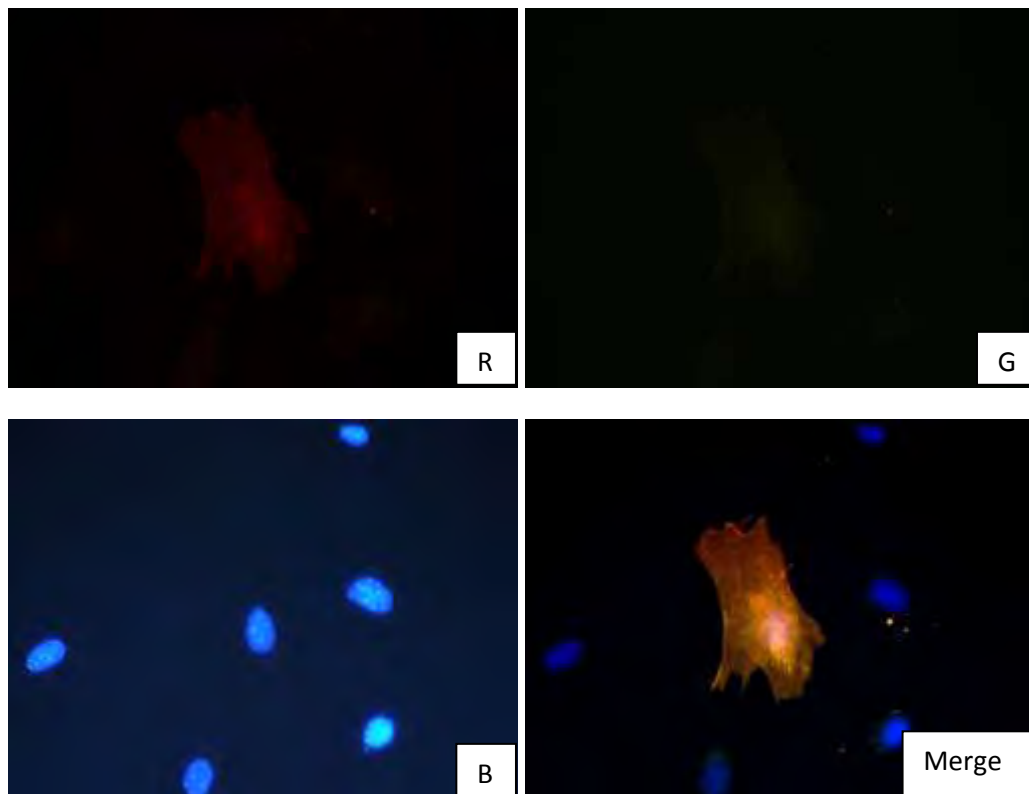

Picture 98

Picture 98 shows the fixed MEF cells transfected with the plasmid pmT/cGi500 and the pUC19. R,G show the cells in the red and green channel respectively while B shows the cells nuclei. Merge is the overlay of the three pictures.

C.11.4 Transfection with pmT/cGi500 + pIC-Cre

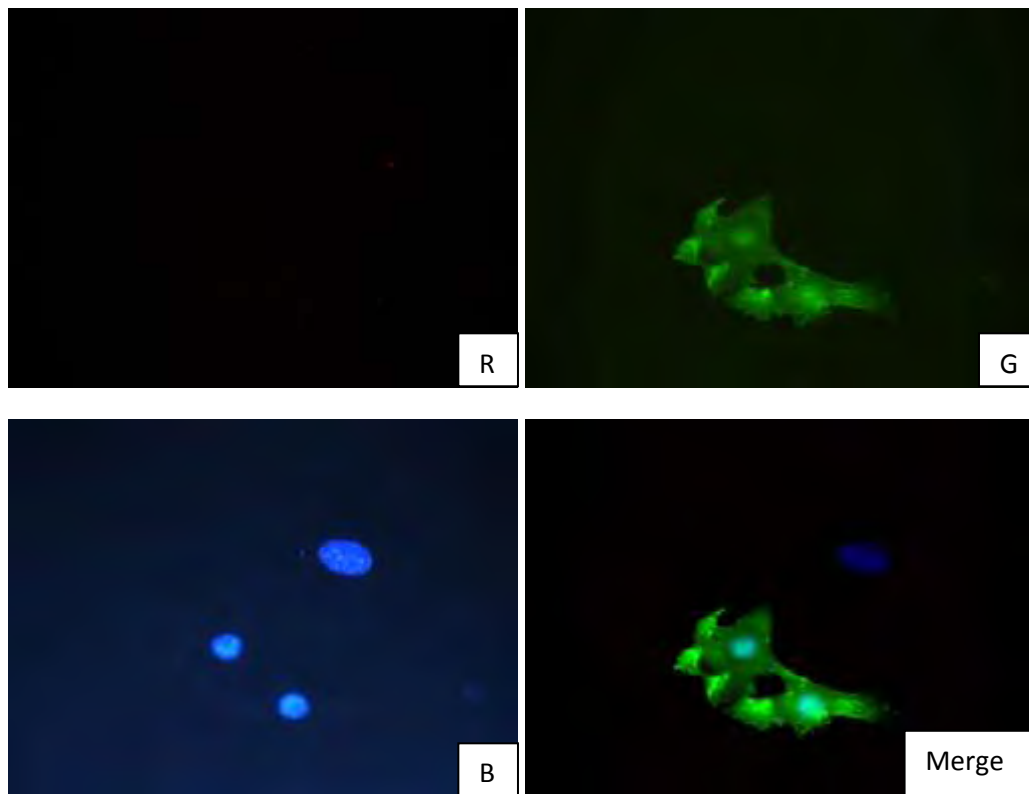

Picture 99

Picture 99 shows the fixed MEF cells transfected with the plasmid pmT/cGi500 and the pIC-Cre. R,G show the cells in the red and green channel respectively while B shows the cells nuclei. Merge is the overlay of the three pictures

Transfection with pmT/cGi500 + pIC-Cre

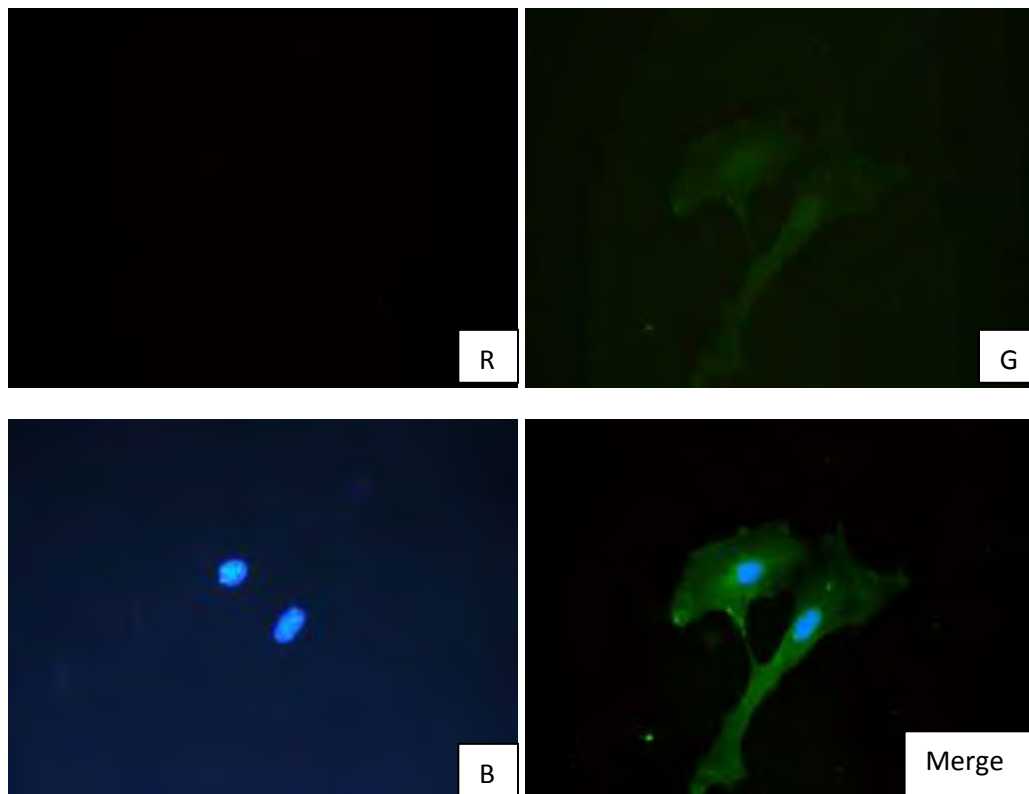

Picture 100

Picture 100 shows the fixed MEF cells transfected with the plasmid pmT/cGi500 and the pIC-Cre. R,G show the cells in the red and green channel respectively while B shows the cells nuclei. Merge is the overlay of the three pictures

D. Discussion

Using site specific recombination techniques it is now able to produce transgenic animal models for a variety of human diseases. The laboratory mouse is now one of the most popular animal-models. It's a mammal, small, breeds fast, and can be easily and relatively economically kept in the laboratory. The site-specific recombination system, Cre / lox, is now widely used to generate knockout and knock-in transgenic mice. It involves the construction of a «floxed» mouse which is a mouse that carries two loxP sites surrounding an exon that we want to silence. The introduction of two loxP sites is done by homologous recombination in ES cells, which are then injected into blastocysts and those in foster mothers for gestation. Then the above mouse is crossed with another one which expresses a tissue specific Cre recombinase. The tissue-specificity of the Cre can be easily driven by a tissue specific promoter. In the recombined offsprings of the above crossing, the «floxed» exon will be excised in all the tissues where the Cre is expressed. Moreover, it is possible to control the time onset of the Cre expression; using CreEr^{T2} recombinases (see Introduction). The Cre/lox system can be also used to create chromosomal rearrangements. Many human cancers, which are known to be caused by chromosomal translocations, have now been modeled in mice through this system.

Apart from cancer, heart diseases are also a large group of diseases that stimulate the biomedical community's research interest. Today it is yet known that the drugs used in angina pectoris, pulmonary hypertension or erectile dysfunction, in anti-thrombosis and atherosclerosis treatment are based on signaling through cyclic GMP. Exploring the ways in which cGMP is involved in these (patho-) physiological functions will allow apart from understanding these processes, to design more effective and perhaps with less side effects, medications and therapies.

On the other hand, of great research interest is the cell tracking in order to monitor cell proliferation, migration and cell death in conditions of disease and health. To achieve this, is required a non-invasive cell marker and a tracking technique that does not harm the animal or the cell. Cell labeling may be done for instance by accumulation of a radioactive substance, the 9 - (4-18F-fluoro-3-[hydroxymethyl] butyl) guanine (18F-FHBG) and by detecting it by Positron Emission Tomography PET. More specifically using the targeting vector Rosa26mT/sr39tk the thymidine kinase is activated in cells expressing the Cre. In this way the radioactive product is phosphorylated and cannot exit the cells, where it accumulates. At this point it is possible to detect these cells with PET [15, 16].

In this project, using a well working double fluorescent reporter plasmid (tdTomato before Cre recombination and GFP after Cre recombination) we tried to construct a targeting vector into the Rosa26 locus, that will have a Multiple Cloning Site for unique restriction enzymes in the entire targeting vector. The genetic locus Rosa26 is widely used to generate knock in transgenic mice because it has a significant advantage. First it ensures that the transgene expression is ubiquitous, and the construct will not fall into heterochromatin. Then the transgenic mice are viable and fertile, with no phenotypical changes compared to wild type ones. Finally, the original Rosa26 was placed in the 1st intron of the Rosa26 gene, so that the CAG promoter,

which comprises the cytoskeleton β -actin promoter and the CMV enhancer, will give high expression levels in the transgene compared to endogenous Rosa26 promoter.

In the MCS (multiple cloning site) coding for recognition sites for the enzymes: FseI, XmaI, AsiSI, MluI we sub-cloned the cGMP sensor, cGi-500 and the sr39tk, a thymidine kinase variant of herpes simplex virus. The sensor cGi-500 consists of a cGMP binding domain surrounded by a CFP and a YFP. When the cGMP binds to the sensor the conformation changes (linear) and the two fluorescent proteins are then away from each other so that energy transfer from the CFP to the YFP cannot happen. In that case it is possible to detect the CFP color of the sensor. In absence of cGMP though, the two fluorescent proteins are close enough for FRET to occur. Then it is possible to detect the YFP color. The usefulness of such a system is huge if we consider that it is possible to monitor cGMP levels in living cells and in fact in real time. With these sensors it is now possible to monitor, in living cells, the quantitative variances in cGMP concentration after administration of different drugs.

Additionally, MEF cells transfection with the above constructs showed that it works very well in living cells. The cells showed red fluorescence when co-transfected with pUC19, and green fluorescence when co-transfected with Cre recombinase. The fact proves that the open reading frame has not be affected (shifted) after the whole construction process and that the cells are able to produce functional fluorescent protein. This was also proved by sequencing, which showed that the constructed plasmids are as expected from the Vector NTI TM software.

Finally, the targeting vectors pR26mT/cGi500 and pR26mT/sr39tk were finished by Barbara Birk with constructs and fragments that I isolated. They can now be used to generate genetically modified ES cells and furthermore transgenic mice.

Appendix

I. Project Strategy

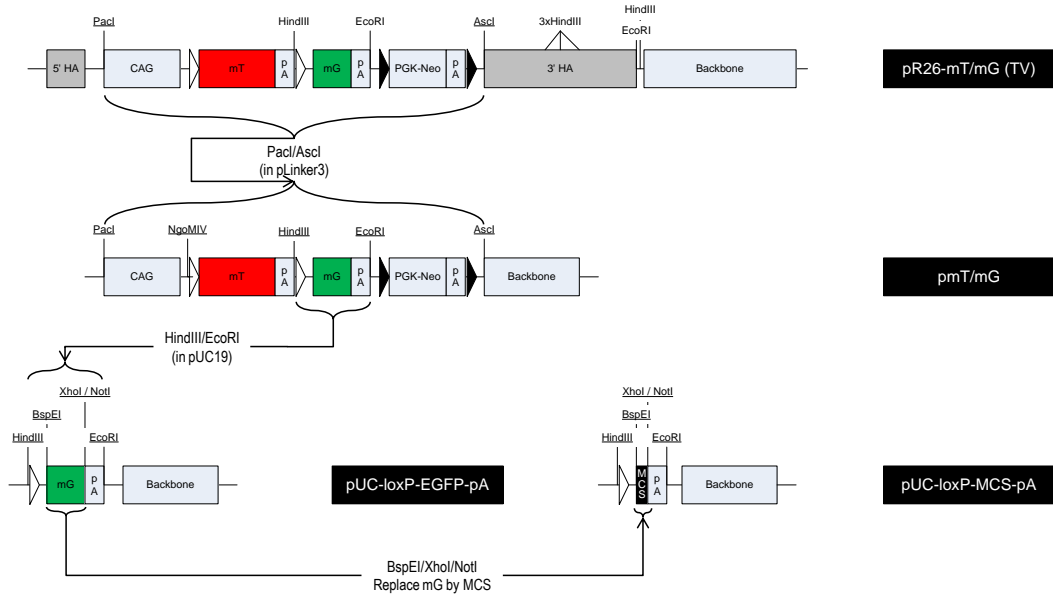

Generation of a pR26-CAG-mT/cGi targeting vector (I)

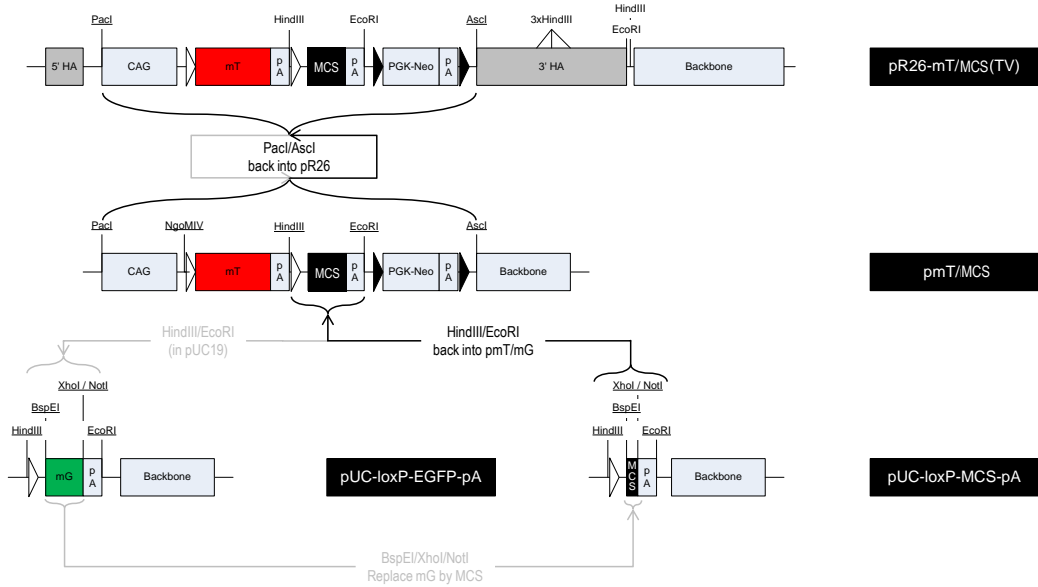

Generation of a pR26-CAG-mT/cGi targeting vector (II)

II. Plasmid Cards

NAME OF PLASMID:		pROSA26 mT/mG	
CONSTRUCTED BY:	Liqun Luo	BOX NO.:	MAXI IV (Tübingen)
REFERENCE:	Muzumdar MD, Tasic B, Miyamichi K, Li L, Luo L: <i>A global double-fluorescent Cre reporter mouse.</i> Genesis. 2007 Sep . 45(9):593-605.	DATE:	10.02.2009
ACCESSION NO:	PMID 17868096, Addgene plasmid 17787	CONC. (µG/µL):	0.75
TOTAL SIZE (BP):	17098	HOST:	E. Coli XL1-Blue
VECTOR SIZE (BP):	4969	BACKBONE:	pBluescript
INSERT SIZE (BP):		GENETIC MARKER:	Amp

DESCRIPTION/CONSTRUCTION DETAILS:

See referenced publication or Addgene database (plasmid 17787).
Generation and Testing of the mT/mG Targeting Construct: [...] The mT/mG construct was assembled within a modified pBluescript II expression vector (pBluescript II0) with a Sall-SpeI-XhoI-SacII-NdeI multi-cloning site. The SpeI-XhoI restriction fragment of p302 (GenBank accession number U51223, a gift from Dr. B. Sauer) (Sauer, 1993) was subcloned into pBluescript II0. The XhoIBamHI restriction fragment of p302 was subcloned into the standard pBluescript vector, and the BamHI site was modified to a SacII site with oligonucleotides. The XhoISacII restriction fragment was introduced into pBluescript II0 to make Sall-loxP-pA-loxP-SacII-NdeI (p302-1). Restriction sites BamHI and XhoI were introduced into the 50 and 30 ends of mT by PCR and this PCR fragment was subcloned into pGEM-T (Promega), sequenced, and then introduced into p302-1 to make loxP-mT-pA-loxP. Restriction sites SacII and NdeI were introduced into the 50 and 30 ends of the mG-pA by PCR. This PCR fragment was subcloned into pGEM-T, sequenced, and then introduced into the loxP-mT-pA-loxP vector to make loxP-mT-pA-loxP-mG-pA0. Finally, the 150-bp SacII fragment of the GFP N-terminus region was subcloned into loxP-mT-pA-loxP-mG-pA0 to make loxP-mT-pA-loxP-mG-pA (mT/mG) flanked by the restriction sites Sall and NdeI. The mT/mG sequence excised with Sall and NdeI was subcloned into an expression vector containing a CMV chicken bactin enhancer-promoter (pCA-HZ2) (Zong et al., 2005) by blunt end ligation. Orientation of pCA-mT/mG was verified by BamHI restriction digest. [...] Following verification of construct function in vitro, an FRT-flanked Neo cassette (selectable marker) was subcloned distal to the mG-pA in pCA-mT/mG via EcoRI and Ascl restriction sites added to the 50 and 30 ends of pL451 (NCI) (Liu et al., 2003). The resulting vector was sequenced, cut with PacI and Ascl, and subcloned into the ROSA26 targeting vector (Srinivas et al., 2001).

MAP:

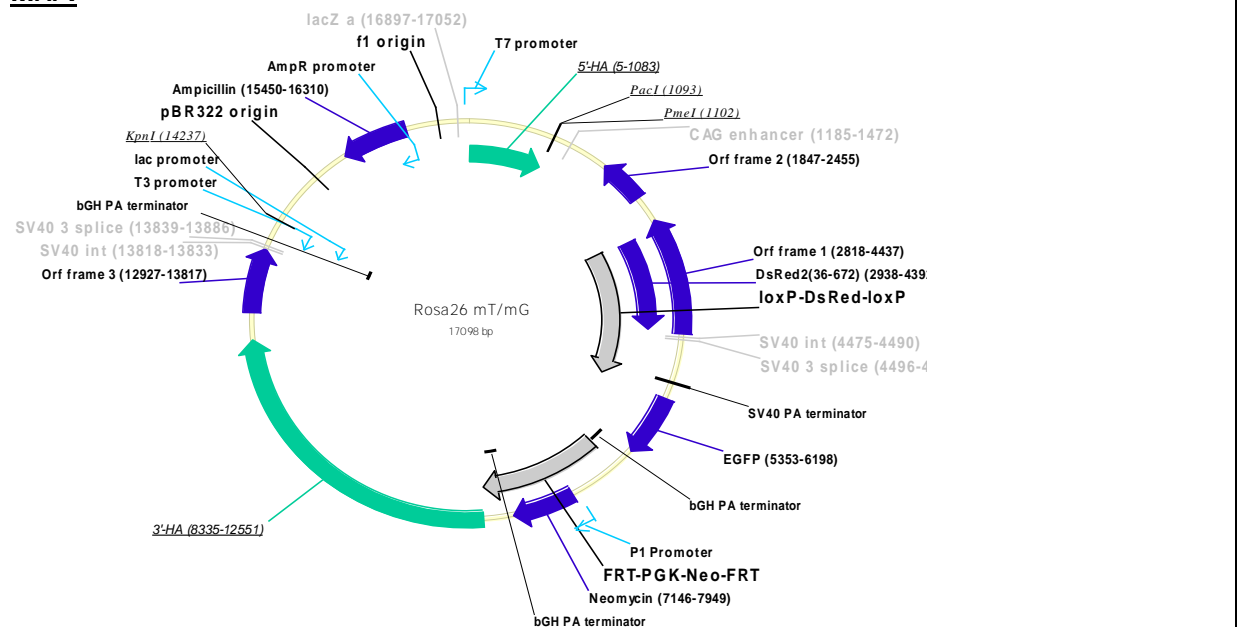

DATE	VERSION	EDITOR
10.2.2009	1	Martin Thunemann

NAME OF PLASMID: pLinker3

CONSTRUCTED BY: Martin Thunemann **BOX NO.:** Maxi IV Tübingen
REFERENCE: **DATE:** 26.03.2009
ACCESSION NO: **CONC. (µG/µL):** 1

TOTAL SIZE (BP): 2677 **HOST:** *E. coli* XL1-blue
VECTOR SIZE (BP): 2635 **BACKBONE:** pUC19
INSERT SIZE (BP): 42 **GENETIC MARKER:** Ampicillin

DESCRIPTION/CONSTRUCTION DETAILS:
 Hybridized and phosphorylated plinker3_fwd and pLinker3_rev linker oligos building a cloning site with *PacI*, *FseI*, *NotI*, *SmiI*, *AscI* restriction sites were ligated into *EcoRI*/*HindIII* digested pUC19.

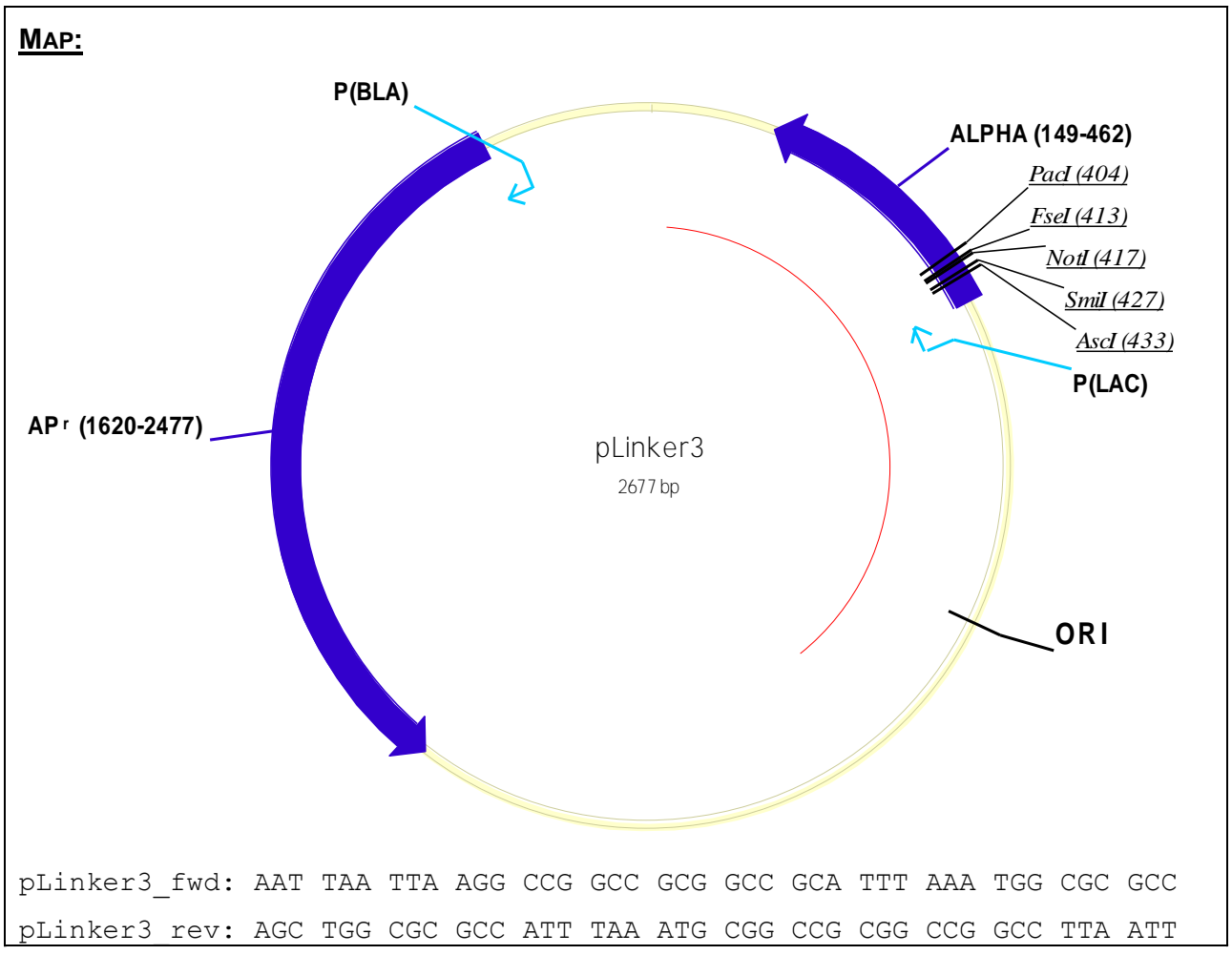

NAME OF PLASMID:	pmTmG
-------------------------	--------------

CONSTRUCTED BY:	Angelos Vachaviolos	BOX NO.:	Maxi IV Tübingen
REFERENCE:		DATE:	24.04.2010
ACCESSION NO:		CONC. (µG/µL):	1

TOTAL SIZE (BP):	9884	HOST:	<i>E. coli</i> XL1-blue
VECTOR SIZE (BP):	2648	BACKBONE:	pUC19
INSERT SIZE (BP):	7236	GENETIC MARKER:	Ampicillin

DESCRIPTION/CONSTRUCTION DETAILS:

The plasmid mTmG contains a loxP-flanked mT (tdTomato) downstream of the CAG promoter, followed by a mGFP and a FRT-PGK-Neo-FRT element.

To generate the mTmG plasmid (9884 bp), pROSA26-mT/mG plasmid (L. Luo) was digested with PacI and AscI restriction enzymes producing a 7236 bp size fragment. This fragment was subcloned into the PacI, AscI digested pLinker3 plasmid (2648 bp, M. Thunemann).

The construct shows expression of mT after transfection in COS-7 cells and expression of mG after co-transfection with Cre in COS-7 cells.

MAP:

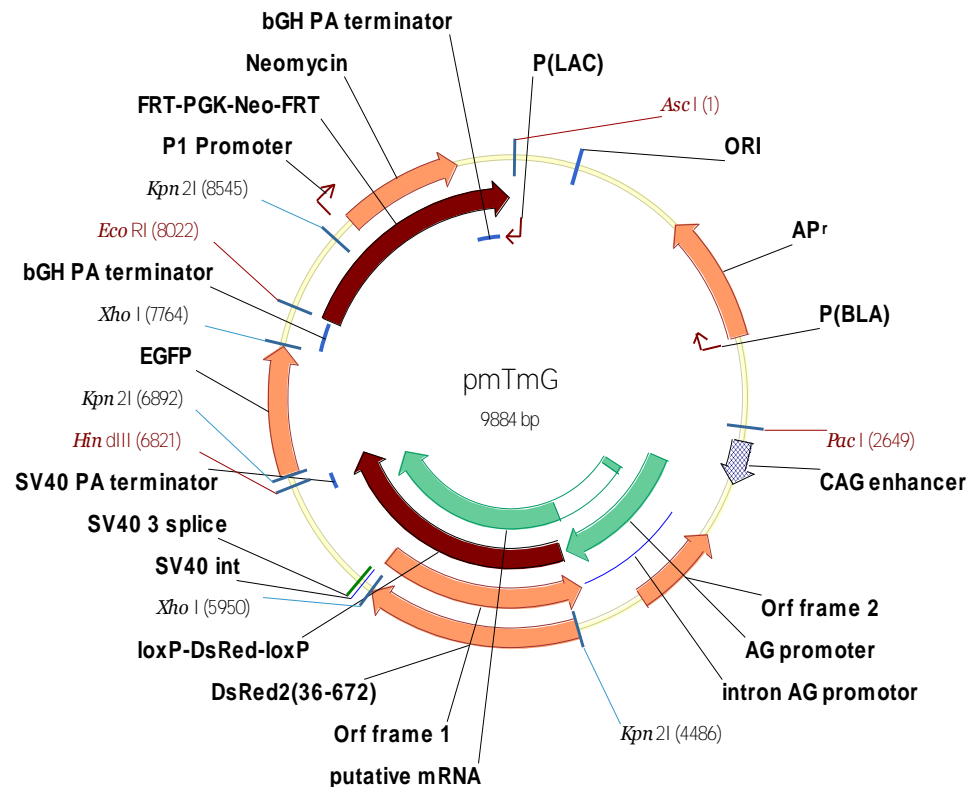

NAME OF PLASMID: pUC-loxP-EGFP-pA

CONSTRUCTED BY: Angelos Vachaviolos	BOX NO.: Maxi IV Tübingen
REFERENCE:	DATE: 07.05.2010
ACCESSION NO:	CONC. (µG/µL): 1

TOTAL SIZE (BP): 3836	HOST: <i>E. coli</i> XL1-blue
VECTOR SIZE (BP): 2635	BACKBONE: pUC19
INSERT SIZE (BP): 1201	GENETIC MARKER: Ampicillin

DESCRIPTION/CONSTRUCTION DETAILS:
 loxP-mG-pA fragment from pmT/mG digested with EcoRI/HindIII, was subcloned into EcoRI/HindIII digested pUC19.

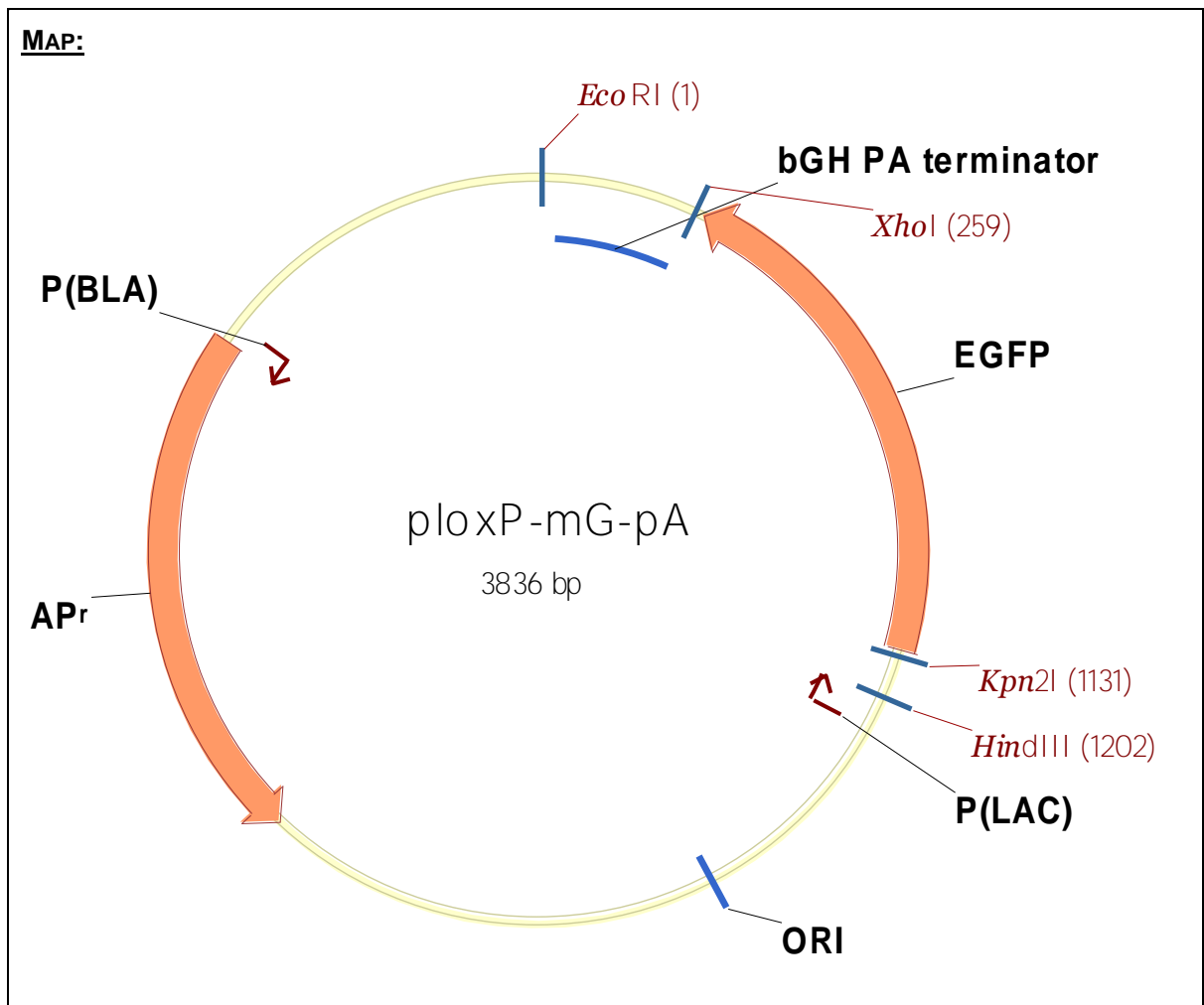

NAME OF PLASMID: pUC-loxP-MCS-pA

CONSTRUCTED BY: Angelos Vachaviolos **BOX NO.:** Maxi IV Tübingen
REFERENCE: **DATE:** 01.06.2010
ACCESSION NO: **CONC. (µg/µL):** 1

TOTAL SIZE (BP): 3004 **HOST:** *E. coli* XL1-blue
VECTOR SIZE (BP): 2964 **BACKBONE:** pUC19
INSERT SIZE (BP): 40 **GENETIC MARKER:** Ampicillin

DESCRIPTION/CONSTRUCTION DETAILS:

To generate the pUC-loxP-MCS-pA plasmid, the mG fragment was excised from pUC-loxP-EGFP-pA by Kpn2I/XhoI and replaced with an oligo for FseI, MluI, XmaI, AsiSI restriction sites.

MAP:

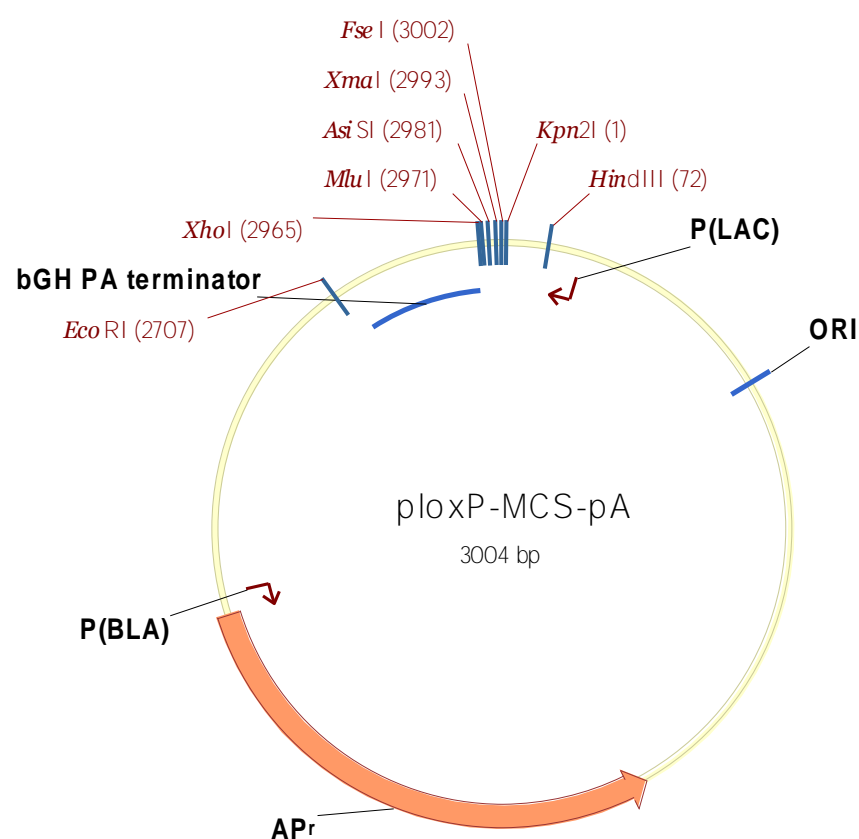

MCS_fwd: CCGGAGGCCGGCCGGGTATCAGTGGCGATCGCACGCGTC

MCS_rev: TCGAGACGCGTGCGATCGCCACTGATACCCGGGCCGCGCT

NAME OF PLASMID:	pLinker5
-------------------------	-----------------

CONSTRUCTED BY:	Angelos Vachaviolos	BOX NO.:	Maxi IV Tübingen
REFERENCE:		DATE:	01.06.2010
ACCESSION NO:		CONC. (µg/µL):	1

TOTAL SIZE (BP):	2687	HOST:	<i>E. coli</i> XL1-blue
VECTOR SIZE (BP):	2635	BACKBONE:	pUC19
INSERT SIZE (BP):	52	GENETIC MARKER:	Ampicillin

DESCRIPTION/CONSTRUCTION DETAILS:

Hybridized and phosphorylated AV_Linker_rev and AV_Linker_fwd oligos building a cloning site with *FseI*, *NcoI*, *HindIII*, *BamHI*, *EcoRI*, *MluI* restriction sites, were ligated into *EcoRI/HindIII* digested pUC19.

MAP:

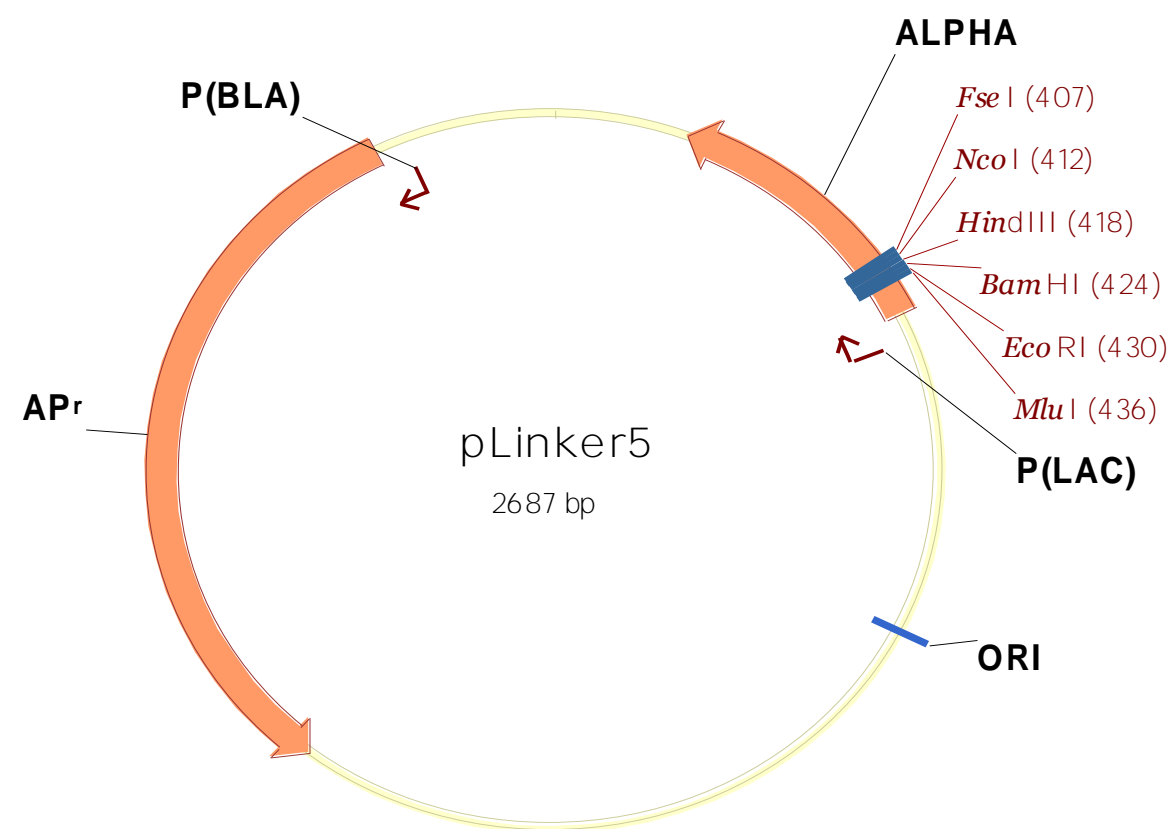

AV_Linker_rev: AGC TGC GAT CGC ACG CGT GAA TTC GGA TCC AAG CTT CCA TGG CTG GCC GGC C

AV Linker_fwd: AAT TGG CCG GCC AGC CAT GGA AGC TTG GAT CCG AAT TCA CGC GTG CGA TCG C

NAME OF PLASMID:	pmT/MCS
-------------------------	----------------

CONSTRUCTED BY:	Angelos Vachaviolos	BOX NO.:	Maxi IV Tübingen
REFERENCE:		DATE:	15.06.2010
ACCESSION NO:		CONC. (µG/µL):	1

TOTAL SIZE (BP):	9052	HOST:	<i>E. coli</i> XL1-blue
VECTOR SIZE (BP):	2648	BACKBONE:	pUC19
INSERT SIZE (BP):	6404	GENETIC MARKER:	Ampicillin

DESCRIPTION/CONSTRUCTION DETAILS:

The plasmid mT/MCS contains a loxP-flanked mT (tdTomato) downstream of the CAG promoter, followed by a Multiple Cloning site for FseI, AsiSI, MluI, XmaI and a FRT-PGK-Neo-FRT element.

To generate the mT/MCS plasmid (9052 bp), pmT/mG plasmid was modified and the mG fragment was removed with EcoRI and HindIII and replaced by a MCS.

MAP:

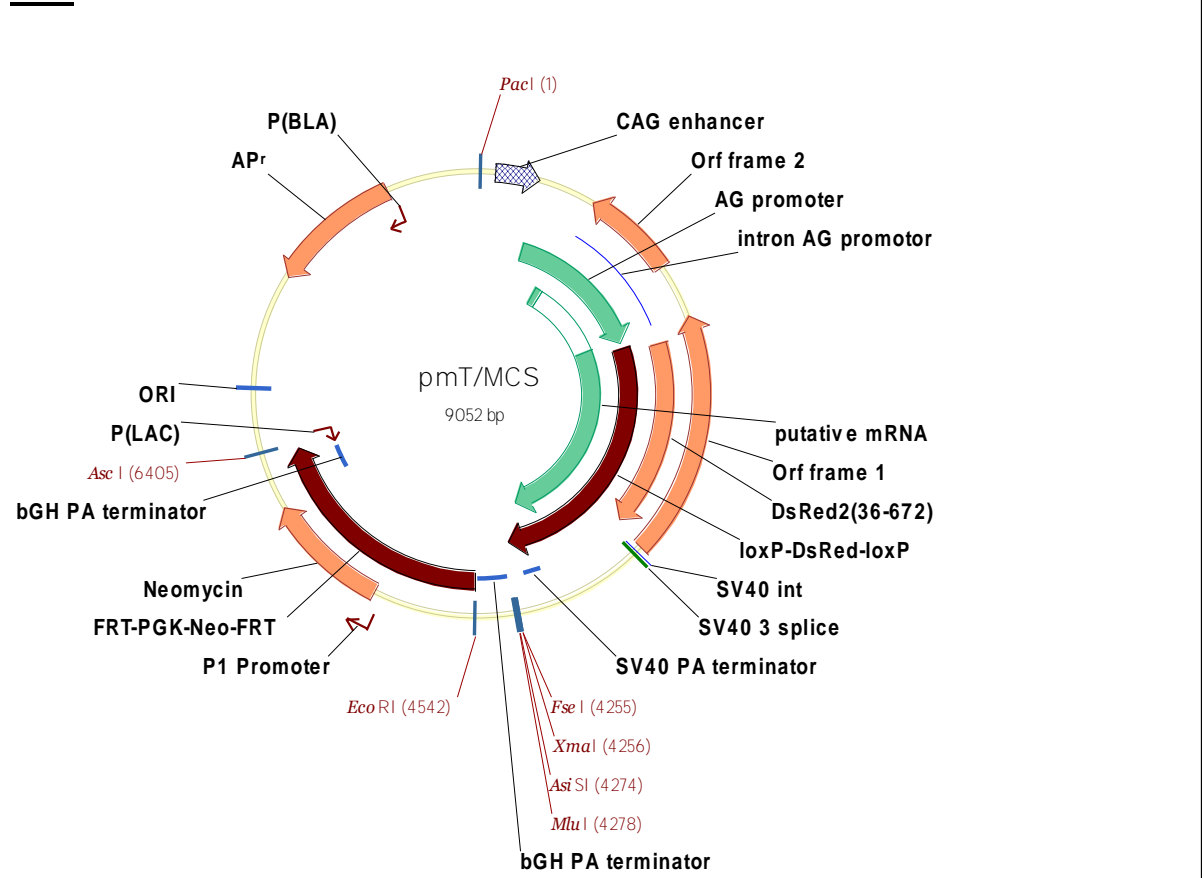

NAME OF PLASMID:	pmT/cGi500
-------------------------	-------------------

CONSTRUCTED BY:	Angelos Vachaviolos	BOX NO.:	Maxi IV Tübingen
REFERENCE:		DATE:	26 .06.2010
ACCESSION NO:		CONC. (µG/µL):	1

TOTAL SIZE (BP):	11297	HOST:	<i>E. coli</i> XL1-blue
VECTOR SIZE (BP):	9033	BACKBONE:	pUC19
INSERT SIZE (BP):	2264	GENETIC MARKER:	Ampicillin

DESCRIPTION/CONSTRUCTION DETAILS:

The plasmid mT/cGi500 contains a loxP-flanked mT (tdTomato) downstream of the CAG promoter, followed by a FRET-based cGMP sensor (cGi500) and a FRT-PGK-Neo-FRT element. To generate the mT/cGi500 plasmid (11297 bp), mT/MCS plasmid was digested with FseI and AsiSI producing a 9033bp vector to host the FseI, AsiSI digested pl5cGi500 fragment (2264bp).

MAP:

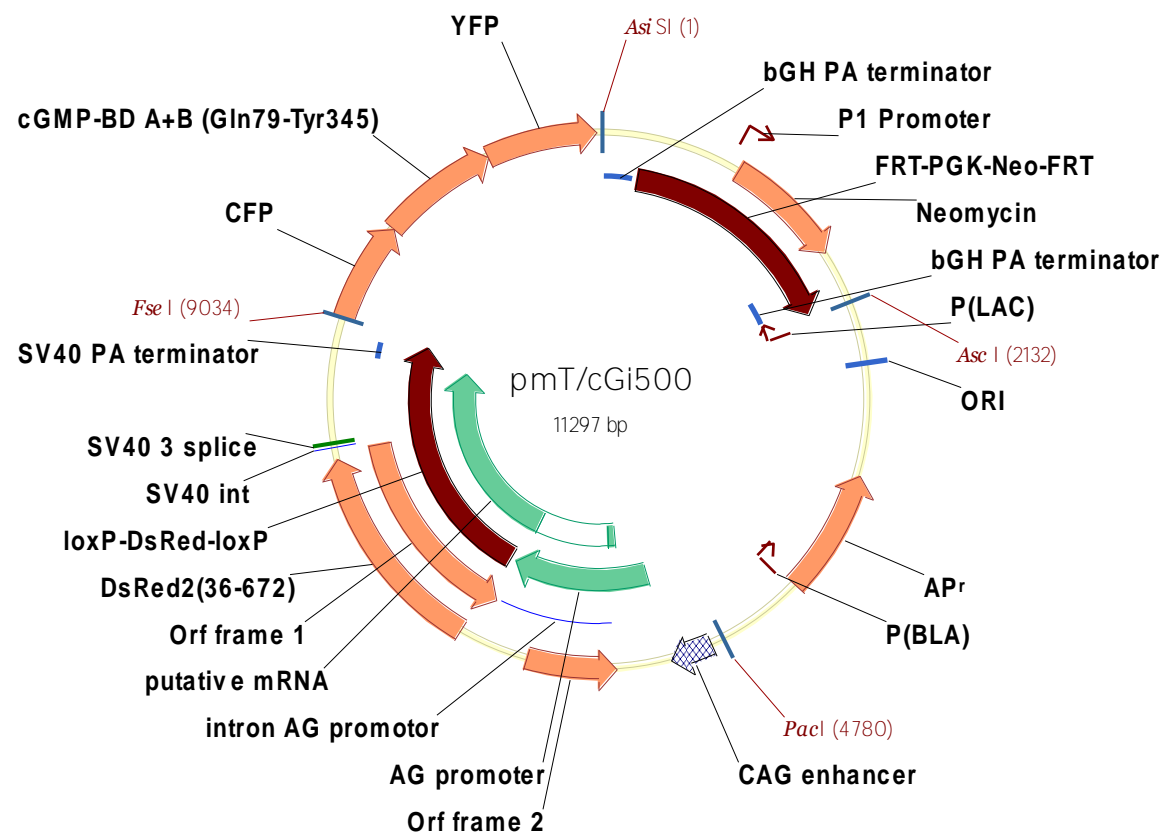

NAME OF PLASMID:	pmT/sr39tk
-------------------------	-------------------

CONSTRUCTED BY:	Angelos Vachaviolos	BOX NO.:	Maxi IV Tübingen
REFERENCE:		DATE:	08 .07.2010
ACCESSION NO:		CONC. (µG/µL):	1

TOTAL SIZE (BP):	10214	HOST:	<i>E. coli</i> XL1-blue
VECTOR SIZE (BP):	9033	BACKBONE:	pUC19
INSERT SIZE (BP):	1181	GENETIC MARKER:	Ampicillin

DESCRIPTION/CONSTRUCTION DETAILS:
 The plasmid mT/sr39tk contains a loxP-flanked mT (tdTomato) downstream of the CAG promoter, followed by a sr39 thymidine kinase and a FRT-PGK-Neo-FRT element. To generate the mT/sr39tk plasmid (10214 bp), mT/MCS plasmid was digested with FseI and AsiSI producing a 9033bp vector to host the FseI, AsiSI digested pl5sr39tk fragment(1181bp).

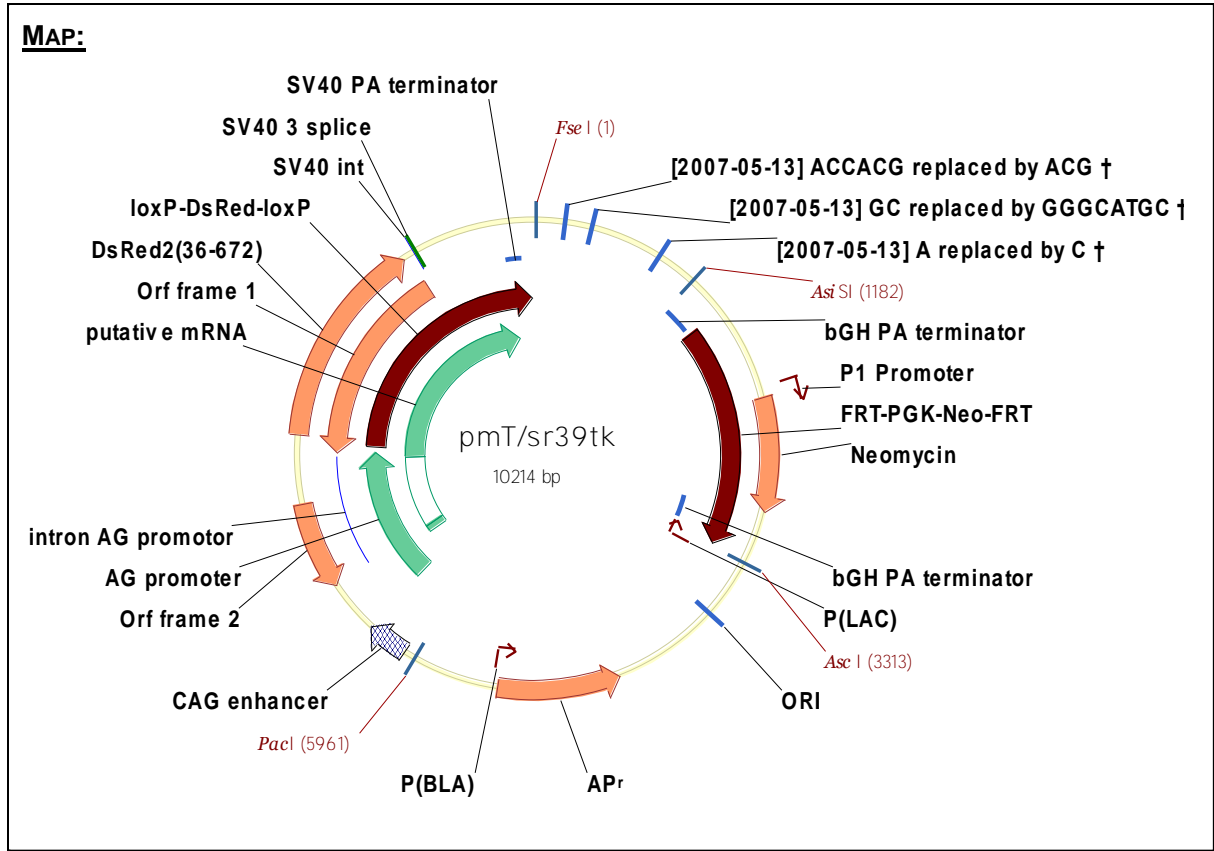

NAME OF PLASMID: Rosa26 mT/cGi500 (Targeting Vector)

CONSTRUCTED BY: Angelos Vachaviolos **BOX NO.:** Maxi IV Tübingen
REFERENCE: **DATE:** -
ACCESSION NO: **CONC. (µG/µL):** 1

TOTAL SIZE (BP): 18497 **HOST:** *E. coli* XL1-blue
VECTOR SIZE (BP): 9862 **BACKBONE:** pUC19
INSERT SIZE (BP): 8635 **GENETIC MARKER:** Ampicillin

DESCRIPTION/CONSTRUCTION DETAILS:
 The plasmid Rosa26 mT/cGi500 contains a loxP-flanked mT (tdTomato) downstream of the CAG promoter, followed by a Fret-based cGMP sensor (cGi500) and a FRT-PGK-Neo-FRT element.
 To generate the Rosa26 mT/cGi500 plasmid (18497 bp), Rosa26 mT/mG plasmid was digested with *AscI*/*PacI* producing a 9862bp vector to host the *AscI*/*PacI* digested pmTcGi500 fragment (8635bp).

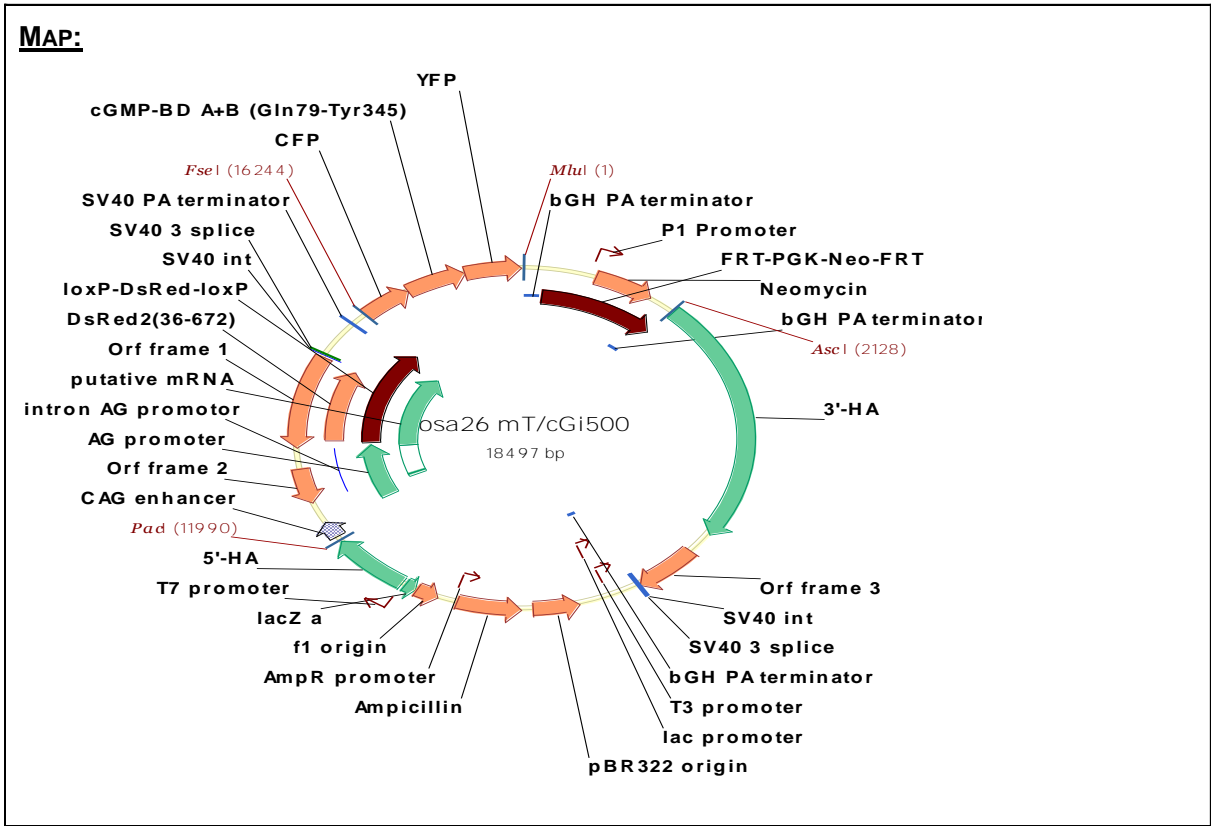

NAME OF PLASMID:	Rosa26 mT/sr39tk (Targeting Vector)
-------------------------	--

CONSTRUCTED BY:	Angelos Vachaviolos	BOX NO.:	Maxi IV Tübingen
REFERENCE:		DATE:	-
ACCESSION NO:		CONC. (µG/µL):	1

TOTAL SIZE (BP):	17428	HOST:	<i>E. coli</i> XL1-blue
VECTOR SIZE (BP):	9862	BACKBONE:	pUC19
INSERT SIZE (BP):	7566	GENETIC MARKER:	Ampicillin

DESCRIPTION/CONSTRUCTION DETAILS:
 The plasmid Rosa26 mT/sr39tk contains a loxP-flanked mT (tdTomato) downstream of the CAG promoter, followed by a sr39 thymidine kinase and a FRT-PGK-Neo-FRT element. To generate the Rosa26 mT/sr39tk plasmid (17428 bp), Rosa26 mT/mG plasmid was digested with *AscI*/*PacI* producing a 9862bp vector to host the *AscI*/*PacI* digested pmT/sr39tk fragment(7566bp).

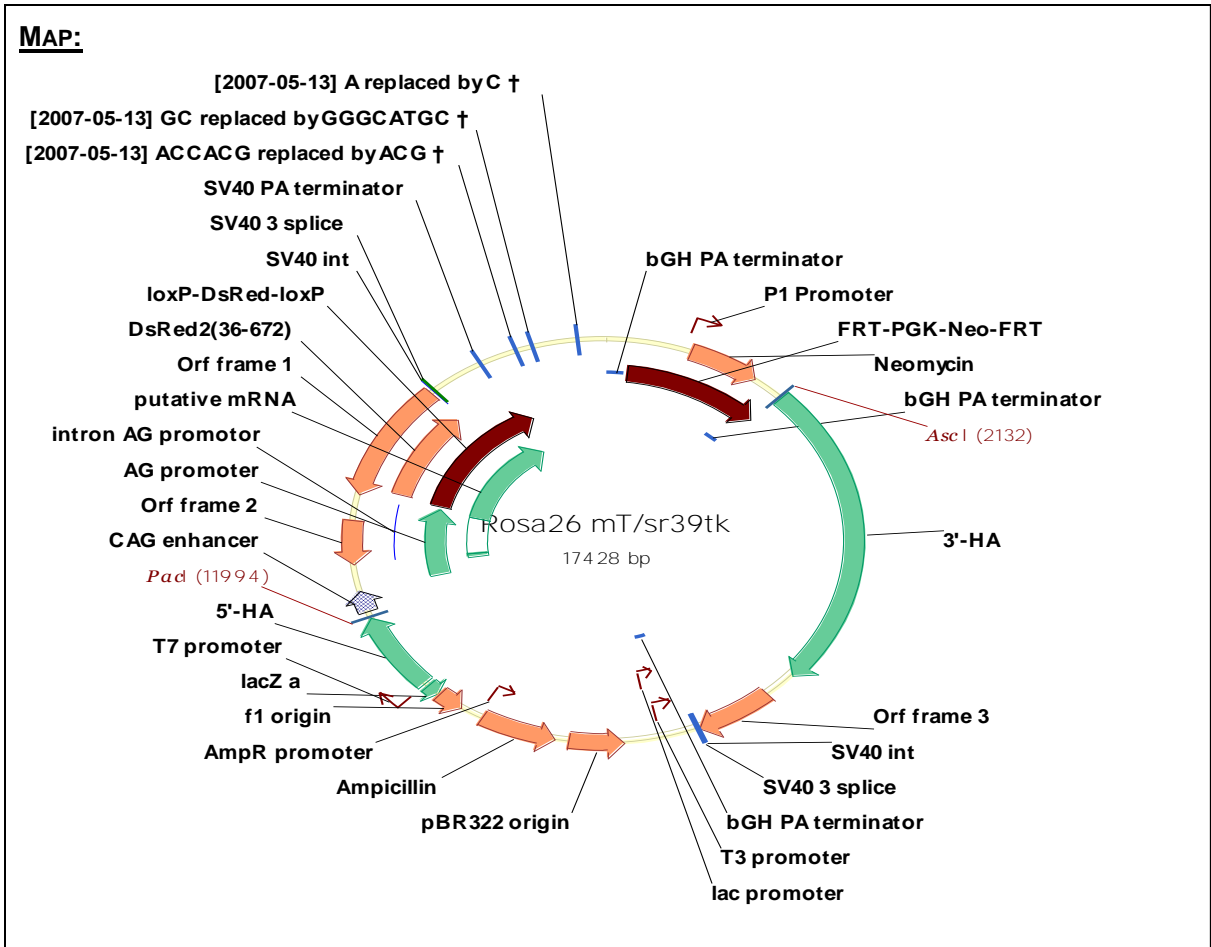

NAME OF PLASMID:	Rosa26 mT/MCS (Targeting Vector)
-------------------------	---

CONSTRUCTED BY:	Angelos Vachaviolos	BOX NO.:	Maxi IV Tübingen
REFERENCE:		DATE:	-
ACCESSION NO:		CONC. (µG/µL):	1

TOTAL SIZE (BP):	16266	HOST:	<i>E. coli</i> XL1-blue
VECTOR SIZE (BP):	9862	BACKBONE:	pUC19
INSERT SIZE (BP):	6472	GENETIC MARKER:	Ampicillin

DESCRIPTION/CONSTRUCTION DETAILS:

The plasmid Rosa26 mT/MCS contains a loxP-flanked mT (tdTomato) downstream of the CAG promoter, followed by a Multiple Cloning Site and a FRT-PGK-Neo-FRT element. To generate the Rosa26 mT/MCS plasmid (16266 bp), Rosa26 mT/mG plasmid was digested with *AscI*/*PacI* producing a 9862bp vector to host the *AscI*/*PacI* digested pmTMCS fragment (6742bp).

MAP:

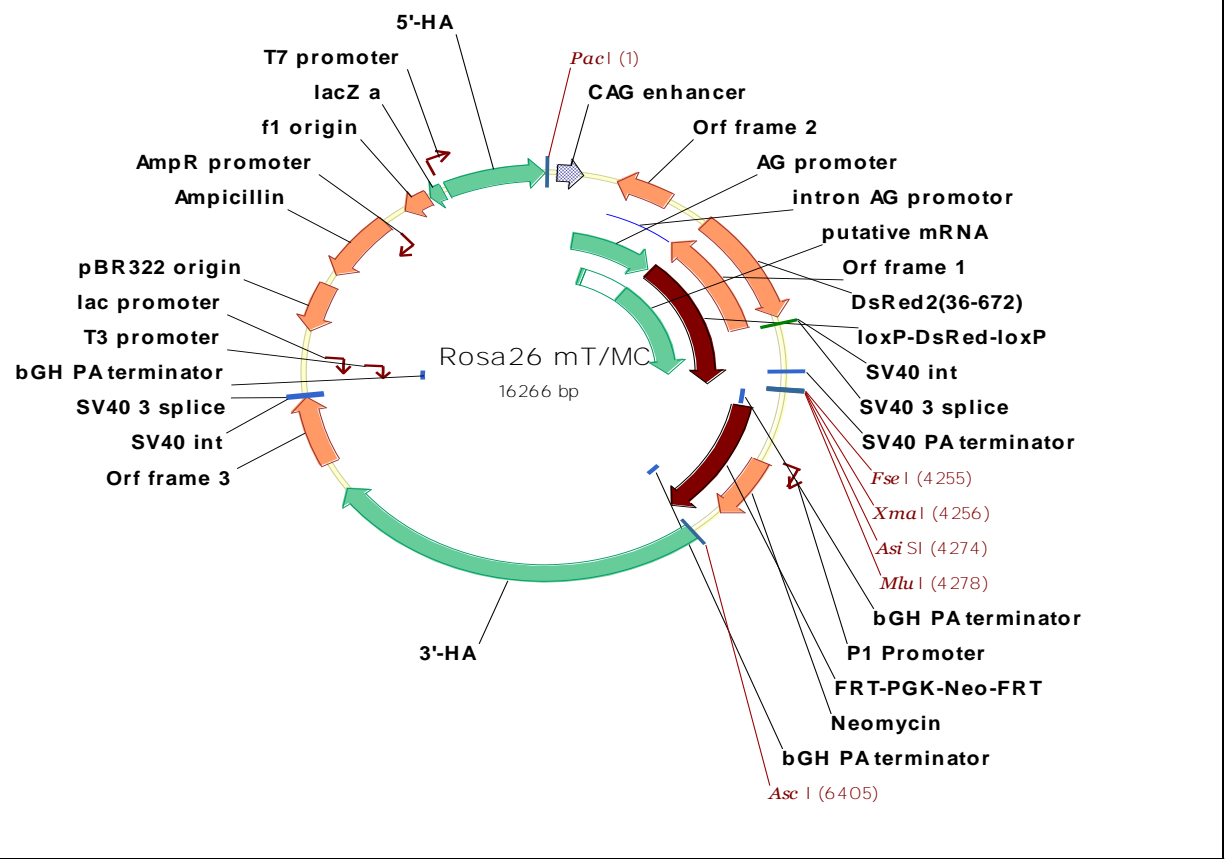

III. Cell Culture Plan

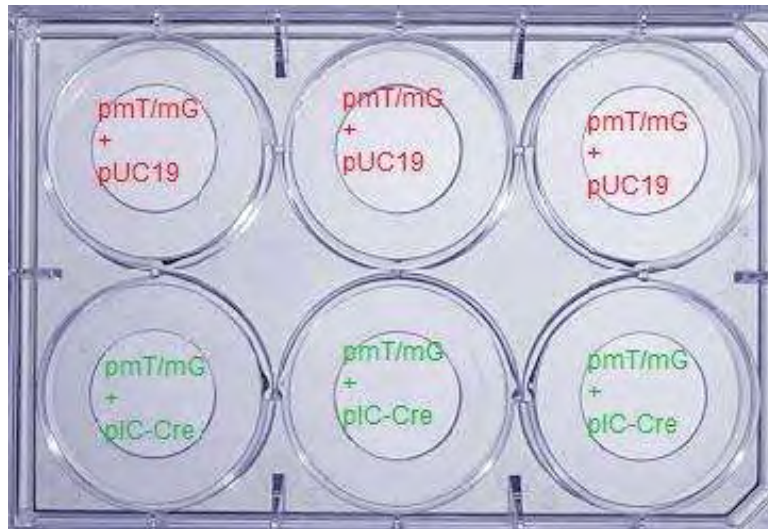

Per well has been used:

2 μ g of pUC19

2 μ g of pIC-Cre

3 μ g of pmTmG

3 μ g of pmTcGi500

IV. Abbreviations

Amp: Ampicillin

bp: base pairs

CFP: Cyan Fluorescent Protein

cGMP: cyclic Guanosine Monophosphate

dH₂O: de-ionized water

EDTA: Ethylene Diamine Tetra Acetate

FRET: Fluorescence Resonance Energy transfer

GC: Guanylyl Cyclase

GFP: Green Fluorescent Protein

Kb: kilo bases

MCS: Multiple Cloning Site

MEF: Mouse Embryonic Fibroblast

mG: membrane targeted GFP

mT: membrane targeted td Tomato

Neo: neomycin

OD: Optical Density

SSR: Site Specific Recombinase

tk: thymidine kinase

YFP: Yellow Fluorescent Protein

 : loxP site

 : FRT site

References:

1. **Mandar Deepak Muzumdar et al.**, 2007, A Global Double-Fluorescent Cre Reporter Mouse, *Genesis* 45:593–605.
2. **Kimberly A. Lucas et al.**, 2000, Guanylyl Cyclases and Signaling by Cyclic GMP, *Pharmacol Rev* 52:375–413, 2000
3. **Robert Feil et al.**, 2003 Cyclic GMP–Dependent Protein Kinases and the Cardiovascular System: Insights From Genetically Modified Mice, *Circ. Res.* 2003;93:907-916
4. **Alexander Lange**, 2006, Die NO/cGMP-vermittelte Signaltransduktion in der glatten Muskulatur, Bochum
5. **Zhenyu Li et al.**, 2003, A Stimulatory Role for cGMP-Dependent Protein Kinase in Platelet Activation, *Cell*, Vol. 112, 77–86
6. **Barbara Kemp-Harper et al.**, 2008, cGMP Matters, *Science Signaling* 1 (9), pe12
7. **Andrew T. Bender et al.**, 2006, Cyclic Nucleotide Phosphodiesterases: Molecular Regulation to Clinical Use, *Pharmacol Rev* 58:488–520, 2006
8. **F. Hofmann et al.**, 2006, Function of cGMP-Dependent Protein Kinases as Revealed by Gene Deletion, *Physiol Rev* 86: 1–23, 2006
9. **Michael Föllner et al.**, 2008, Anemia and splenomegaly in cGKI-deficient mice, *PNAS*, vol. 105, no. 18, 6771–6776
10. **Robert Feil et al.**, 2006, cGMP signalling: from bench to bedside, *EMBO reports* (2006) 7, 149–153
11. **Robert Feil**, 2007, Conditional Somatic Mutagenesis in the Mouse Using Site-Specific Recombinases, *HEP* (2007) 178:3–28
12. **Daniel Metzger et al.**, 1999, Engineering the mouse genome by site-specific recombination, *Current Opinion in Biotechnology* 1999, 10:470–476
13. **Robert Lukowski et al.**, Cre/loxP vermittelte konditionale Mutagenese des cGMP Signalwegs in der Maus, *Biospektrum* 3/05
14. **Michael Russwurm et al.**, 2007, Design of fluorescence resonance energy transfer (FRET)-based cGMP indicators: a systematic approach, *Biochem. J.* (2007) 407, 69–77
15. **Yuxin Lu et al.**, 2006, Noninvasive imaging of islet grafts using positron-emission tomography, 11294–11299 *PNAS*
16. **Leeta Alison Green et al.**, 2004, A Tracer Kinetic Model for ¹⁸F-FHBG for Quantitating Herpes Simplex Virus Type 1 Thymidine Kinase Reporter Gene Expression in Living Animals Using PET, *J. Nucl. Med.* 2004; 45:1560–1570
17. **Annika N Alexopoulou et al.**, 2008, The CMV early enhancer/chicken β actin (CAG) promoter can be used to drive transgene expression during the differentiation of murine embryonic stem cells into vascular progenitors, *BMC Cell Biology* 2008, 9:2
18. **Philippe Soriano et al.**, 1999, Generalized lacZ expression with the ROSA26 Cre reporter strain, *nature genetics* • volume 21

... Many thanks go to...

I would like here to thank everybody for helping me accomplish this diploma project. Thanks to my family that supported me (economically+ psychologically)!!! Thanks to my Greek teachers that gave me the necessary knowledge to be able to understand and do such a project!

But in particular:

First of all many thanks to Martin Thunemann, my supervisor in the lab. Especially in the first time when he really had to do a lot of babysitting and stand my silly questions! And because I was unique in converting my experiments into disaster. Thank you Martin for staying calm, kind, patient and always ready to help me!

It would be very rude of me if I forgot to thank our Technical Assistant Barbara Birk. Barbara thank you so much for all the help with the reagents in the lab, and for teaching me all these techniques, thank you for staying so late in the lab waiting for me to inoculate my maxi preps. Thank you for your great sense of humor! You knew how to cheer me up when I was really disappointed and discouraged from the bad results! Thank you a lot for our (little-quasi) trips around Tübingen! Hab dich Lieb!

Sandeep, Lai, I all thank you for your great sense of humor and your jokes especially at the "Mittagessen" time. I will never forget the: "Dude, this is not science! You put your DNA..."!!!

Finally, all my grateful thanks go to Prof. Robert Feil!!! Mr. Feil thank you for accepting me in your Lab! Thank you for all your questions that stressed me a lot I have to admit. This is how I learned why we centrifuge before we inoculate a maxi prep, how a ligase works or even how a sequencer works. Please don't be mad at me, because I can't remember the chemical structure of an ATP molecule!

Susi, thank you for your kindness and your sweet, cozy smile!

Thank you Lisa for your help concerning writing my thesis, and the ligation reaction ratios! Thank you also for your jokes and your stories that used to make my day!

Once again, Ich möchte mich hier noch mal ganz herzlich bei euch ALLEN bedanken!

Angelos Vachaviolos
Sept. 2010