

Analysis of Inland Container Terminal

Katsikavelis Kostantinos
Bourazanis Evangelos



Master of Science Thesis
UTH Mechanical Engineering
State-of-the-Art Design and Analysis Methods in Industry
38334 VOLOS

Approved by the three members of the Commission of Inquiry

Chief Examiner
(Supervisor)

Dr. Athanasios Ziliaskopoulos
Professor in Optimization of Production/Transportation Systems
Department of Mechanical Engineering, University of Thessaly

Second Examiner

Dr. George Liberopoulos
Professor in Stochastic Methods in Production Management
Department of Mechanical Engineering, University of Thessaly

Third Examiner

Dr Dimitrios Pantelis
Assistant Professor in Stochastic Operations Research Standards in Industrial
Management
Department of Mechanical Engineering, University of Thessaly

Abstract

The growing focus on inland/dry ports is indicative of transport development strategies gradually shifting inland to address capacity and efficiency issues in the light of global supply chains. The complexity of modern freight distribution, the increased focus on intermodal transport solutions and capacity issues appear to be the main drivers. The larger volumes of flows in networks, through a concentration of cargo on a limited set of ports of call and associated trunk lines to the hinterland, have also created the right conditions for nodes to appear along and at the end of these trunk lines. In the light of technological, market and supply chain changes, this thesis looks at how inland terminals play a role in the organization of regional freight distribution.

Abstract

Η συνεχής αύξηση της προσοχής που δίνεται στους λιμένες εσωτερικού είναι ενδεικτικό της σταδιακής μετάβασης στα ενδότερα, για κάλυψη των αναγκών σε χωρητικότητα και απόδοση των παγκοσμίων αλυσίδων διανομής. Η πολυπλοκότητα της τωρινής διανομής φόρτου, η αυξημένη προσοχή στις λύσεις συνδυασμένων μεταφορών και ζητημάτων χωρητικότητας μονοπωλούν το ενδιαφέρον. Οι μεγαλύτεροι όγκοι σε ροές στα δίκτυα, μέσα από τη συγκέντρωση του φόρτου σε περιορισμένο αριθμό λιμένων και σε συσχετισμένες κύριες αρτηρίες μεταφοράς στο εσωτερικό, δημιούργησαν τις κατάλληλες συνθήκες να εμφανιστούν κόμβοι στα ανάμεσα και στο τέρμα αυτών. Υπό το πρίσμα της τεχνολογίας, της αγοράς και των αλυσίδων διανομής, αυτή η διπλωματική εργασία, εξετάζει τους λιμένες εσωτερικού και πως αυτοί παίζουν ρόλο στην οργάνωση της τοπικής κατανομής φόρτου.

FOREWORD

First of all, we want to express our deeper regards to Professor A. Ziliaskopoulos and especially to his assistant Dr. A. Lois for their invaluable support in our thesis. Secondly, we would like to thank Professor George Liberopoulos and Assistant Professor Dimitrios Pantelis for their participation. At last, we would like to thank our families for their help and tolerance.

Katsikavelis Kostantinos & Bourazanis Evangelos

Volos, July 2017

TABLE OF CONTENTS

FOREWORD	5
TABLE OF CONTENTS	6
TABLE OF FIGURES	9
TABLES	11
1 INTRODUCTION	12
1.1 Background	12
1.2 Containerisation	12
1.2.1 Origin	13
1.2.2 Twentieth Century	13
1.2.3 Effects	15
1.2.4 Twenty-First Century	15
1.3 The role of transportation in logistics chain	17
1.3.1 Definitions	17
1.3.2 Components of Logistics System	18
1.3.3 History and Advancement of Logistics	19
1.4 Interrelationships Between Transportation and Logistics	20
1.4.1 Transport Costs and Goods Characters in Logistics	20
1.4.2 The Effects of Transportation on Logistics Activities	21
1.4.3 The Role of Transportation in Service Quality	21
1.5 Forms of Logistics Operation	21
1.5.1 Supply Chain Management	21
1.5.2 Reverse Logistics	22
1.5.3 Maritime Logistics	24
1.5.4 Air Freight Logistics	24
1.5.5 Land Logistics	24
1.5.6 Express Delivery	25
1.5.7 E-commerce	25
2 INFRASTRUCTURES	27
2.1 Intermodal terminal concepts in Europe	27
2.2 Terminal design, process organisation and equipment in the U.S.	28
2.3 Recent developments in terminal design and equipment	31
2.4 Infrastructure	33
2.4.1 Warehouses	33
2.4.2 Container Lay Down Area	33
2.4.3 Intermodal Yard	34
2.4.4 Customs facility	34
2.5 Container Handling Equipment	34
2.6 Customer's intermodal "life cycle"	39
2.7 Size of intermodal terminals	41

3 CONTAINER & EQUIPMENT	42
3.1 Container	42
3.2 Container-Carriers	49
4 BUSINESS MODELS	52
4.1 Intermodal business models in Europe	52
4.2 Intermodal business models in North America	54
4.3 Comparison of American and European intermodal business models	57
5 STATISTICS	59
5.1 Comparison of intermodal volume in North America and Europe 2007	59
6 MANAGEMENT & FINANCE	61
6.1 Intermodal Wagon Management	61
6.2 Intermodal wagon management in the U.S.	61
6.3 Comparison of intermodal wagon management in the U.S. and Europe	63
6.4 Financing of intermodal terminal investments	64
7 INTERMODAL GROWTH	66
7.1 Key drivers of intermodal growth in Europe	66
7.2 Key drivers of intermodal growth in U.S.	67
8 DESIGN PROCESS	69
8.1 Geo-Positions	69
8.2 The cost calculation module	74
8.3 Dry Ports in Europe	75
8.4 Logistics Park Kansas City Intermodal Facility	79
8.4.1 Inland Port VIII	81
8.4.2 Inland Port XXXI	82
8.4.3 Inland Port XXXII	84
8.4.4 The Value of Co-Location	85
8.4.5 Site Selection Features & Benefits	86
8.4.6 Infrastructure Surrounding LPKC	86
8.4.7 Container Yard / Drayage Services	87
8.4.8 Development Partners	88
9 INLAND PORT DESIGN	89
9.1 Necessity of Building an Intermodal Station in Greece	89
9.2 Decision Making Process for Choosing the hub Position.	89
9.2 Selecting the appropriate position	92
9.2 Services	100
9.3 Costs	101
9.4 Preliminary economic evaluation	102
9.5 Proposal for Construction	106
10 CONCLUSION	108
10.1 Conclusion	108

11 REFERENCE

Table of Figures

Figure 1. First container transports.....	16
Figure 2. Overview of Logistics System (source: BTRE, 2001)	18
Figure 3. Logistics historical development	19
Figure 4. Cost ratio of logistics items (modified: Chang, 1998).....	20
Figure 5. Interaction of business processes and supply chain (source: Cooper et al., 1997).....	22
Figure 6. Consumer supply chain from, Krumwiede et al., 2002	23
Figure 7. Third-party reverse logistics from, http://www.fedex.com/us/solutions/downloads/acer.pdf	23
Figure 8. The transport pattern of traditional.....	26
Figure 9. The transport pattern of e-commerce Business.....	26
Figure 10. Bedford Yard in Chicago	27
Figure 11. Transshipment station for intermodal transport, from Munich Riem station.	28
Figure 12. Typical terminal concept in Europe: cross-section.....	28
Figure 13. UP intermodal terminal ICTF Los Angeles (CA): aerial and cross-section, from Port of Los Angeles.	30
Figure 14. BNSF intermodal terminal Alliance (TX): aerial and layout map, from BNSF	31
Figure 15. BNSF terminal Southern California International Gateway (SCIG) in Los Angeles (CA): cross-section of facility, from Port of Los Angeles.	32
Figure 16. Redesign of UP's intermodal terminal ICTF Los Angeles (CA), from Port of Los Angeles.	33
Figure 17. Container lay down area, from http://www.metrans.eu/terminal-operations/rail-hub-terminal-prague-uhrineves-cz/	34
Figure 18. Rail Mounted Gantry Crane (RMG), from https://www.liebherr.com/en/rou/products/maritime-cranes/port-equipment/rail-mounted-stacking-cranes/rail-mounted-gantry-cranes.html	35
Figure 19. Rail Mounted Gantry Crane (RMG), from http://www.konecranes.com/equipment/container-handling-equipment/rail-mounted-gantry-cranes	35
Figure 20. Rubber Tired Gantry Crane (RTG), from http://www.konecranes.com/equipment/container-handling-equipment/rubber-tired-gantry-cranes	36
Figure 21. Straddle Carrier, from http://www.konecranes.com/equipment/container-handling-equipment/straddle-carriers	37
Figure 22. Reach Stackers, from http://www.konecranes.com/equipment/lift-trucks/reach-stackers	37
Figure 23. Container Lift Trucks, from http://www.konecranes.com/equipment/lift-trucks/container-lift-trucks	38
Figure 24. Sidelifter, from http://www.konecranes.com/equipment/lift-trucks/reach-stackers	38
Figure 25. A straight mast container handler at Haikou Xiuying Port, Hainan, China, from https://en.wikipedia.org/wiki/Forklift#/media/File:Straight_mast_container_handler_02.jpg	38
Figure 26. Automated Gate System: driver clearance post,.....	40
Figure 27. Automated Gate Systems at CN intermodal facility in Brampton, from CN International.....	40
Figure 28. Commonly used container lengths, from https://commons.wikimedia.org/w/index.php?curid=41113427	42
Figure 29. 20 feet container, from https://www.hapag-lloyd.com/en/products/fleet/container.html	43
Figure 30. 40 feet container, from https://www.hapag-lloyd.com/en/products/fleet/container.html	44
Figure 31. 40 feet high cube container, from https://www.hapag-lloyd.com/en/products/fleet/container.html	45
Figure 32. 20 feet open top container, from https://www.hapag-lloyd.com/en/products/fleet/container.html	45
Figure 33. 40 feet open top container, from https://www.hapag-lloyd.com/en/products/fleet/container.html	46
Figure 34. Roof and door openings for 20 & 40 feet open top containers, from https://www.hapag-lloyd.com/en/products/fleet/container.html	46
Figure 35. 20 feet flat container, from https://www.hapag-lloyd.com/en/products/fleet/container.html	47
Figure 36. 40 feet flat container, from https://www.hapag-lloyd.com/en/products/fleet/container.html	47
Figure 37. 20/40 feet flat-collapsible container, from https://www.hapag-lloyd.com/en/products/fleet/container.html	47
Figure 38. 20 feet high cube container, from https://www.hapag-lloyd.com/en/products/fleet/container.html	48
Figure 39. 20 feet refrigerated container, from https://www.hapag-lloyd.com/en/products/fleet/container.html	48
Figure 40. 40 feet refrigerated container, from https://www.hapag-lloyd.com/en/products/fleet/container.html	48
Figure 41. 20 feet tank container, from https://www.hapag-lloyd.com/en/products/fleet/container.html	49

Figure 42. Tanktainer & open-topped container covered by a fabric curtain, from https://en.wikipedia.org/wiki/Flatcar#/media/File:Railroad_car_with_container_loads.jpg .	49
Figure 43. Double-stacked container well cars, from https://en.wikipedia.org/wiki/Well_car#/media/File:DTTX_724681_20050529_IL_Rochelle.jpg .	50
Figure 44. Highway semi-trailers in piggyback service at Albuquerque, New Mexico, from https://en.wikipedia.org/wiki/Intermodal_freight_transport#/media/File:Roadrailleurs.jpg .	51
Figure 45. Business model of European intermodal traffic: generalist type of intermodal operator	53
Figure 46. Business model in U.S. international intermodal traffic	55
Figure 47. Business model in U.S. domestic intermodal traffic	56
Figure 48. Intermodal traffic of UIRR member companies: 1970-2007	60
Figure 49. TTX Company's ownership	61
Figure 50. Most common intermodal wagons in North America, from https://www.bsnf.com .	63
Figure 51. Logistics polarisation in the Rhine-Scheldt Delta: logistics zones, trimodal dry ports, rail-based dry ports and barge-based dry ports, Notteboom (2000)	70
Figure 52. Main Container Ports, Trade Corridors and Distribution Hubs in North America, Cushman & Wakefield (2009).	72
Figure 53. Prague-Uhrineves (CZ) dry port	75
Figure 54. Budapest (HU) dry port	77
Figure 55. Dunajska Streda (SK) dry port	78
Figure 56. Inland Port VIII	82
Figure 57. Inland Port XXXI	83
Figure 58. Inland Port XXXII	85
Figure 59. LPKC facilities	87
Figure 60. Main Container Ports, Trade Corridors and Distribution Hubs in North America, Cushman & Wakefield (2009).	90
Figure 61. Intermodal terminals & interchange points in North America, Cushman & Wakefield (2009)	90
Figure 62. Logistics polarisation in the Rhine-Scheldt Delta: logistics zones, trimodal dry ports, rail-based dry ports and barge-based dry ports, Notteboom (2000)	91
Figure 63. European Rail Freight Corridors	93
Figure 64. RFC 7 Members	93
Figure 65. Rail network in Greece	94
Figure 66. TEU Volume in Greece	95
Figure 67. Area of development in Kileler, Larissa, from http://www.arcgis.com/apps/Compare/storytelling_tabbed/index.html?appid=9c32a112c1274e14af5db5ef70b67176	97
Figure 68. Area of development in Kileler, Larissa, from http://www.arcgis.com/apps/Compare/storytelling_tabbed/index.html?appid=9c32a112c1274e14af5db5ef70b67176	97
Figure 69. Area of development in Thessaloniki, from http://www.arcgis.com/apps/Compare/storytelling_tabbed/index.html?appid=9c32a112c1274e14af5db5ef70b67176	99
Figure 70. Area of development in Thessaloniki, from http://www.arcgis.com/apps/Compare/storytelling_tabbed/index.html?appid=9c32a112c1274e14af5db5ef70b67176	100

Tables

Table 1 Inland Port Characteristics.....	29
Table 2. Handling volume of Union Pacific’ major intermodal terminals: 2007.....	41
Table 3. TEU capacities.....	43
Table 4. Key actors of intermodal traffic in Europe.....	58
Table 5. Intermodal traffic in North America, USA and Europe by segments: 2007.....	59
Table 6 Financing of Intermodal Stations.....	65
Table 7 Key Drivers of Intermodal Growth.....	68
Table 8 Location of Intermodal Stations.....	74
Table 9. Prague-Uhrineves (CZ) dry port facts.....	75
Table 10. Budapest (HU) dry port facts.....	77
Table 11. Dunajska Streda (SK) dry port facts.....	79
Table 12. Inland Port VIII specifications.....	82
Table 13. Inland Port VIII specifications.....	84
Table 14 TEU Volume in Greece.....	92
Table 15. TEU Volume in Greece.....	95
Table 16. Building Costs of Intermodal Station.....	101
Table 17. Estimated investment expenditure for the base case facility.....	102
Table 18. Investment for the Hypothetical Intermodal Facility.....	103
Table 19. Estimated Annual Operating Costs for Intermodal Terminal.....	103
Table 20. Model Sensitivity Cost Per Lift at Different Annual Lift Volumes.....	105

1 INTRODUCTION

This chapter describes the background of inland ports, as it includes the containerisation and the general concept of logistics.

1.1 Background

In many places around the world, bimodal and trimodal inland terminals have become an intrinsic part of the transport system, particularly in regions having a high reliance on trade. Transport development is gradually shifting inland after a phase that focused on the development of port terminals and maritime shipping networks. There are many reasons for this growing attention. The complexity of modern freight distribution, the increased focus on intermodal transport solutions and capacity issues appear to be the main drivers. While trucking tends to be sufficient in the initial phase of the development of inland freight distribution systems, at some level of activity, diminishing returns such as congestion, energy consumption and empty movements become strong incentives to consider the establishment of inland terminals as the next step in regional freight planning. The massification (i.e. economies of scale through larger volumes) of flows in networks, through a concentration of cargo on a limited set of ports of call and associated trunk lines to the hinterland, has also created the right conditions for nodes to appear along and at the end of these trunk lines.

The evolution of inland freight distribution can be seen as a cycle in the ongoing development of containerization and intermodal transport. The geographical characteristics linked with modal availability and the capacity of regional inland access are important in shaping this development. Thus, there is no single strategy in terms of modal preferences, as the regional effect remains fundamental. Each inland port remains the outcome of the considerations of a transport geography pertaining to modal availability and efficiency, market function and intensity, the regulatory framework and governance.

The establishment of global supply chains and the strategy of Asian and Pacific countries focusing on the export-oriented paradigm have been powerful forces shaping contemporary freight distribution. Indirectly, this has forced players in the freight transport industry (shipping companies, terminal operators and logistics providers) to examine supply chains as a whole and to identify legs where capacity and reliability were an issue. Once maritime shipping networks and port terminal activities were better integrated, particularly through the symbiotic relationship between maritime shipping and port operations, inland transport became the obvious focus and the inland terminal became a fundamental component of this strategy. This initially took place in developed countries, particularly in North America and Europe, which tended to be at the receiving end of many containerized supply chains. The focus has also shifted to considering inland terminals for the early stages of global supply chains (outbound logistics), namely in countries having a marked export-oriented function.

In the light of technological, market and supply chain changes, this thesis investigates how inland terminals play a role in the organization of regional freight distribution. The first part aims at analyzing an inland port.

1.2 Containerisation

Containerization is a system of intermodal freight transport using intermodal containers (also called shipping containers and ISO containers) made of weathering steel. The containers have

standardized dimensions. They can be loaded and unloaded, stacked, transported efficiently over long distances, and transferred from one mode of transport to another—container ships, rail transport flatcars, and semi-trailer trucks—without being opened. The handling system is completely mechanized so that all handling is done with cranes and special forklift trucks. All containers are numbered and tracked using computerized systems.

The system, developed after World War II, dramatically reduced the costs of transport, supported the post-war boom in international trade, and was a major element in globalization. Containerization did away with the manual sorting of most shipments and the need for warehousing. It displaced many thousands of dock workers who formerly handled break bulk cargo. Containerization also reduced congestion in ports, significantly shortened shipping time and reduced losses from damage and theft.

1.2.1 Origin

Before containerization, goods were usually handled manually as break bulk cargo. Typically, goods would be loaded onto a vehicle from the factory and taken to a port warehouse where they would be offloaded and stored awaiting the next vessel. When the vessel arrived, they would be moved to the side of the ship along with other cargo to be lowered or carried into the hold and packed by dock workers. The ship might call at several other ports before off-loading a given consignment of cargo. Each port visit would delay the delivery of other cargo. Delivered cargo might then have been offloaded into another warehouse before being picked up and delivered to its destination. Multiple handling and delays made transport costly, time consuming and unreliable.

Containerization has its origins in early coal mining regions in England beginning in the late 18th century. In 1766 James Brindley designed the box boat 'Starvationer' with 10 wooden containers, to transport coal from Worsley Delph (quarry) to Manchester by Bridgewater Canal. In 1795, Benjamin Outram opened the Little Eaton Gangway, upon which coal was carried in wagons built at his Butterley Ironwork. The horse-drawn wheeled wagons on the gangway took the form of containers, which, loaded with coal, could be transhipped from canal barges on the Derby Canal, which Outram had also promoted.

By the 1830s, railroads on several continents were carrying containers that could be transferred to other modes of transport. The Liverpool and Manchester Railway in the United Kingdom was one of these. "Simple rectangular timber boxes, four to a wagon, they were used to convey coal from the Lancashire collieries to Liverpool, where they were transferred to horse-drawn carts by crane." Originally used for moving coal on and off barges, "loose boxes" were used to containerize coal from the late 1780s, at places like the Bridgewater Canal. By the 1840s, iron boxes were in use as well as wooden ones. The early 1900s saw the adoption of closed container boxes designed for movement between road and rail.

1.2.2 Twentieth Century

On 17 May 1917 Benjamin Franklin Fitch inaugurated exploitation of the experimental installation for transfer of the containers called the demountable bodies based on his own design in Cincinnati, Ohio in US. Later in 1919, his system was extended to over 200 containers serving 21 railway stations with 14 freight trucks.

Prior to the Second World War, many European countries independently developed container systems. In 1919, Stanisław Rodowicz, an engineer, developed the first draft of the container

system in Poland. In 1920, he built a prototype of the biaxial wagon. The Polish-Bolshevik War stopped development of the container system in Poland.

In 1926, a regular connection of the luxury passenger train from London to Paris, Golden Arrow/Fleche d'Or, by Southern Railway and French Northern Railway, began. For transport of passengers' baggage four containers were used. These containers were loaded in London or Paris and carried to ports, Dover or Calais, on flat cars in the UK and "CIWL Pullman Golden Arrow Fourgon of CIWL" in France.

At the Second World Motor Transport Congress in Rome, September 1928, Italian senator Silvio Crespi proposed the use of containers for road and railway transport systems, using collaboration rather than competition. This would be done under the auspices of an international organ similar to the Sleeping Car Company, which provided international carriage of passengers in sleeping wagons.

In 1928 Pennsylvania Railroad (PRR) started regular container service in the northeast United States. After the Wall Street Crash of 1929 in New York and the subsequent Great Depression, many countries were without any means of transport for cargo. The railroads were sought as a possibility to transport cargo, and there was an opportunity to bring containers into broader use. Under auspices of the International Chamber of Commerce in Paris in Venice on September 30, 1931, on one of the platforms of the Maritime Station (Mole di Ponente), practical tests were done to assess the best construction for European containers as part of an international competition.

In the same year, 1931, in USA Benjamin Franklin Fitch designed the two largest and heaviest containers in existence anywhere at the time. One measured 17'6" by 8'0" by 8'0" with a capacity of 30,000 pounds in 890 cubic feet, and a second measured 20'0" by 8'0" by 8'0", with a capacity of 50,000 pounds in 1,000 cubic feet.

In November 1932 in Enola the first container terminal in the world was opened by PRR Pennsylvania RailRoad company. The Fitch hooking system was used for reloading of the containers. The development of containerization was created in Europe and the US as a way to revitalize rail companies after the Wall Street Crash of 1929, which had caused economic collapse and reduction in use of all modes of transport.

In the United Kingdom containers were first standardized by the Railway Clearing House (RCH) in the 1920s, allowing both railway owned and privately owned vehicles to be carried on standard container flats. By modern standards these containers were small, being 1.5 or 3.0 meters long (5 or 10 ft), normally wooden and with a curved roof and insufficient strength for stacking. From 1928 the London, Midland and Scottish Railway offered "door to door" intermodal road-rail services using these containers. This standard failed to become popular outside the United Kingdom.

Pallets made their first major appearance during World War II, when the United States military assembled freight on pallets, allowing fast transfer between warehouses, trucks, trains, ships, and aircraft. Because no freight handling was required, fewer personnel were needed and loading times were decreased.

Truck trailers were first carried by railway before World War II, an arrangement often called "piggyback", by the small Class I railroad, the Chicago Great Western in 1936. The Canadian Pacific Railway was a pioneer in piggyback transport, becoming the first major North American railway to introduce the service in 1952. In the United Kingdom, the big four railway companies offered services using standard RCH containers that could be craned on and off the back of trucks. Moving companies such as Pickfords offered private services in the same way.

In the 1950s, a new standardized steel Intermodal container based on specifications from the United States Department of Defense began to revolutionize freight transportation. The International Organization for Standardization (ISO) then issued standards based upon the U.S. Department of Defense standards between 1968 and 1970.

The White Pass and Yukon Route railway acquired the world's first container ship, the Clifford J. Rogers, built in 1955, and introduced containers to its railway in 1956. In the United Kingdom, the modernisation plan and in turn the Beeching Report strongly pushed containerization. The British Railways freightliner service was launched carrying 8-foot (2.4 m) high pre-ISO containers. The older wooden containers and the pre-ISO containers were rapidly replaced by 10-foot (3.0 m) and 20-foot (6.1 m) ISO standard containers, and later by 40-foot (12 m) containers and larger.

In the U.S., starting in the 1960s, the use of containers increased steadily. Rail intermodal traffic tripled between 1980 and 2002, according to the Association of American Railroads (AAR), from 3.1 million trailers and containers to 9.3 million. Large investments were made in intermodal freight projects. An example was the USD \$740,000,000 Port of Oakland intermodal rail facility begun in the late 1980s.

Since 1984, a mechanism for intermodal shipping known as double-stack rail transport has become increasingly common. Rising to the rate of nearly 70% of the United States' intermodal shipments, it transports more than one million containers per year. The double-stack rail cars design significantly reduces damage in transit and provides greater cargo security by cradling the lower containers so their doors cannot be opened. A succession of large, new, domestic container sizes was introduced to increase shipping productivity. In Europe, the more restricted loading gauge has limited the adoption of double-stack cars. However, in 2007 the Betuweroute was completed, a railway from Rotterdam to the German industrial heartland, which may accommodate double-stacked containers in the future. Other countries, like New Zealand, have numerous low tunnels and bridges that limit expansion for economic reasons.

Since electrification generally predated double-stacking, the overhead wiring was too low to accommodate it. However, India is building some freight-only corridors with the overhead wiring at 7.45 m above rail, which is high enough.

1.2.3 Effects

Containerization greatly reduced the expense of international trade and increased its speed, especially of consumer goods and commodities. It also dramatically changed the character of port cities worldwide. Prior to highly mechanized container transfers, crews of 20–22 longshoremen would pack individual cargoes into the hold of a ship. After containerization, large crews of longshoremen were no longer necessary at port facilities, and the profession changed drastically.

1.2.4 Twenty-First Century

As of 2009, approximately 90% of non-bulk cargo worldwide is moved by containers stacked on transport ships; 26% of all container transshipment is carried out in China. For example, in 2009 there were 105,976,701 transshipments in China (both international and coastal, excluding Hong Kong), 21,040,096 in Hong Kong (which is listed separately), and only 34,299,572 in the United States. In 2005, some 18 million containers made over 200 million

trips per year. Some ships can carry over 14,500 twenty-foot equivalent units (TEU), such as the Emma Mærsk, 396 m (1,299 ft) long, launched in August 2006. It has been predicted that, at some point, container ships will be constrained in size only by the depth of the Straits of Malacca, one of the world's busiest shipping lanes, linking the Indian Ocean to the Pacific Ocean. This so-called Malaccamax size constrains a ship to dimensions of 470 m (1,542 ft) in length and 60 m (197 ft) wide.

However, few initially foresaw the extent of the influence of containerization on the shipping industry. In the 1950s, Harvard University economist Benjamin Chinitz predicted that containerization would benefit New York by allowing it to ship its industrial goods more cheaply to the Southern United States than other areas, but he did not anticipate that containerization might make it cheaper to import such goods from abroad. Most economic studies of containerization merely assumed that shipping companies would begin to replace older forms of transportation with containerization, but did not predict that the process of containerization itself would have a more direct influence on the choice of producers and increase the total volume of trade.



Figure 1. First container transports

The widespread use of ISO standard containers has driven modifications in other freight-moving standards, gradually forcing removable truck bodies or swap bodies into standard sizes and shapes (though without the strength needed to be stacked), and changing completely the worldwide use of freight pallets that fit into ISO containers or into commercial vehicles.

Improved cargo security is also an important benefit of containerization. The cargo is not visible to the casual viewer and thus is less likely to be stolen; the doors of the containers are usually sealed so that tampering is more evident. Some containers are fitted with electronic monitoring devices and can be remotely monitored for changes in air pressure, which happens when the doors are opened. This reduced the thefts that had long plagued the shipping industry. Recent developments have focused on the use of intelligent logistics optimization to further enhance security.

The use of the same basic sizes of containers across the globe has lessened the problems caused by incompatible rail gauge sizes in different countries. The majority of the rail networks in the world operate on a 1,435 mm (4 ft 8 1/2 in) gauge track known as standard gauge, but many countries (such as Russia, India, Finland, and Lithuania) use broader gauges, while many others in Africa and South America use narrower gauges on their networks. The use of container trains in all these countries makes transshipment between different trains of different gauges easier.

Containers have become a popular way to ship private cars and other vehicles overseas using 20- or 40-foot containers. Unlike roll-on/roll-off vehicle shipping, personal effects can be loaded into the container with the vehicle, allowing for easy international relocation.

1.3 The role of transportation in logistics chain

Since logistics advanced from 1950s, there were numerous researches focused on this area in different applications. Due to the trend of nationalization and globalization in recent decades, the importance of logistics management has been growing in various areas. For industries, logistics helps to optimize the existing production and distribution processes based on the same resources through management techniques for promoting the efficiency and competitiveness of enterprises. The key element in a logistics chain is transportation system, which joints the separated activities. Transportation occupies one-third of the amount in the logistics costs and transportation systems influence the performance of logistics system hugely. Transporting is required in the whole production procedures, from manufacturing to delivery to the final consumers and returns. Only a good coordination between each component would bring the benefits to a maximum.

1.3.1 Definitions

Council of Logistics Management (1991) defined that logistics is ‘part of the supply chain process that plans, implements, and controls the efficient, effective forward and reverse flow and storage of goods, services, and related information between the point of origin and the point of consumption in order to meet customers’ requirements’. Johnson and Wood’s definition (cited in Tilanus, 1997) uses ‘five important key terms’, which are logistics, inbound logistics, materials management, physical distribution, and supply-chain management, to interpret. Logistics describes the entire process of materials and products moving into, through and out of firm. Inbound logistics covers the movement of material received from suppliers. Materials management describes the movement of materials and components within a firm. Physical distribution refers to the movement of goods outward from the end of the assembly line to the customer. Finally, supply- chain management is somewhat larger than logistics, and it links logistics more directly with the user’s total communications network and with the firm’s engineering staff.

The commonality of the recent definitions is that logistics is a process of moving and handling goods and materials, from the beginning to the end of the production, sale process and waste disposal, to satisfy customers and add business competitiveness. It is ‘the process of anticipating customer needs and wants; acquiring the capital, materials, people, technologies, and information necessary to meet those needs and wants; optimizing the goods- or service-producing network to fulfil customer requests; and utilizing the network to fulfil customer requests in a timely way’ (Tilanus, 1997). Simply to say, ‘logistics is customer-oriented operation management’.

1.3.2 Components of Logistics System

Figure 1 provides an overview of the logistics system. Logistics services, information systems and infrastructure/resources are the three components of this system and closely linked. The interaction of the three main components in the logistics system is interpreted as follows. Logistics services support the movement of materials and products from inputs through production to consumers, as well as associated waste disposal and reverse flows. They include activities undertaken in-house by the users of the services (e.g. storage or inventory control at a manufacturer's plant) and the operations of external service providers.

Logistics services comprise physical activities (e.g. transport, storage) as well as non-physical activities (e.g. supply chain design, selection of contractors, freightage negotiations). Most activities of logistics services are bi-direction. Information systems include modelling and management of decision making, and more important issues are tracking and tracing. It provides essential data and consultation in each step of the interaction among logistics services and the target stations. Infrastructure comprises human resources, financial resources, packaging materials, warehouses, transport and communications. Most fixed capital is for building those infrastructures. They are concrete foundations and basements within logistics systems.

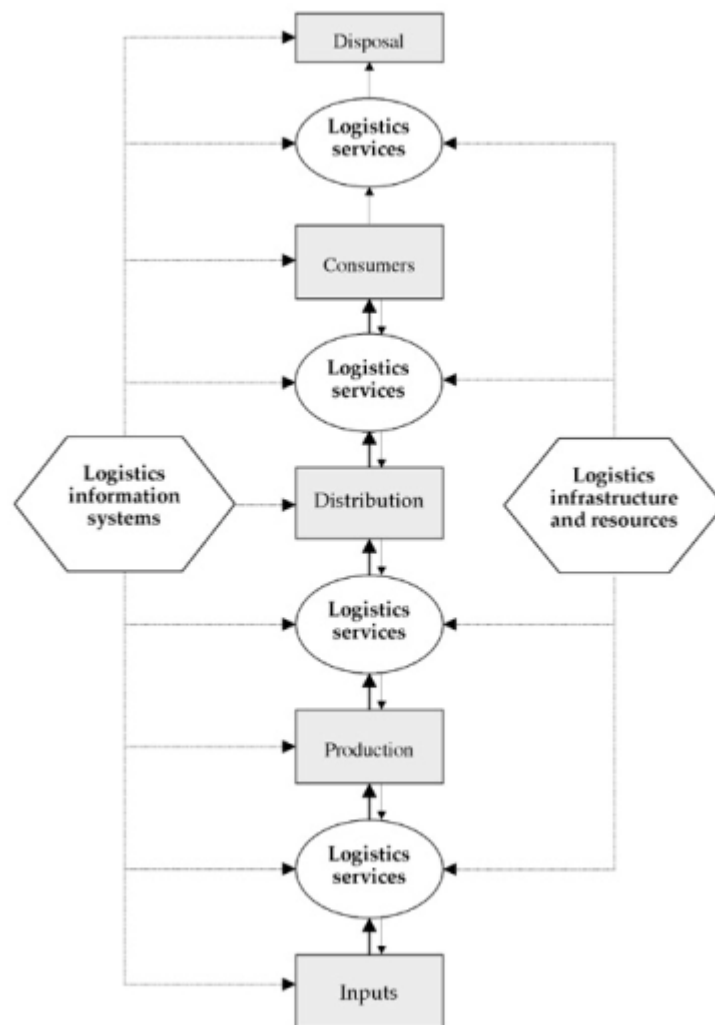

Figure 2. Overview of Logistics System (source: BTRE, 2001)

1.3.3 History and Advancement of Logistics

Logistics was initially a military activity concerned with getting soldiers and munitions to the battlefield in time for flight, but it is now seen as an integral part of the modern production process. The main background of its development is that the recession of America in the 1950s caused the industrial to place importance on goods circulations. The term, logistics, was initially developed in the context of military activities in the late 18th and early 19th centuries and it launched from the military logistics of World War II. The probable origin of the term is the Greek *logistikos*, meaning ‘skilled in calculating’. (BTRE, 2001) Military definitions typically incorporate the supply, movement and quartering of troops in a set. And now, a number of researches were taken and made logistics applications from military activities to business activities.

Business logistics was not an academic subject until the 1960s. A key element of logistics, the trade-off between transport and inventory costs, was formally recognized in economics at least as early as the mid-1880s. (BTRE, 2001) Based on the American experience, the development of logistics could be divided into four periods (Chang, 1998), which are represented as Figure 2.

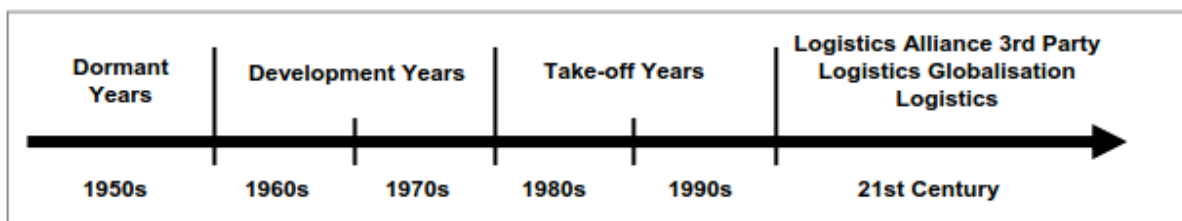

Figure 3. Logistics historical development

Before the 1950s, logistics was under the dormant condition. Production was the main part of the managers concerned, and industry logistics was once regarded as “necessary evil” in this period. During the 1950s to and 1960s, applying new ideas of administration on business was a tendency. Drucker (2001), who thought Logistics was The Economy’s Dark Continent, regarded the procedure of physical distribution after producing products as the most possible development area in American businesses but also the most neglected area. Lewis’s study (cited in Chang, 1998) in 1956 on the role of air transportation in physical distribution was the application of “total cost concept” and it pointed out the notions of trade-off between inventory and transportation. From the 1970s onwards, more and more applications and researches of logistics appeared. Due to petroleum price rise in 1973, the effects of logistics activities on enterprises grew. Slow growth of market, pressure of high stagflation, release of transportation control, and competitions of the third world on products and materials all increased the significance of logistics system on planning and business at that time.

The further tendency of logistics in the early 21st century is logistics alliance, Third Party Logistics (TPL) and globalized logistics. Logistics circulation is an essential of business activities and sustaining competitiveness, however, to conduct and manage a large company is cost consuming and not economic. Therefore, alliance of international industries could save working costs and cooperation with TPL could specialize in logistics area.

1.4 Interrelationships Between Transportation and Logistics

Without well-developed transportation systems, logistics could not bring its advantages into full play. Besides, a good transport system in logistics activities could provide better logistics efficiency, reduce operation cost, and promote service quality. The improvement of transportation systems needs the effort from both public and private sectors. A well-operated logistics system could increase both the competitiveness of the government and enterprises.

1.4.1 Transport Costs and Goods Characters in Logistics

Transport system is the most important economic activity among the components of business logistics systems. Around one third to two thirds of the expenses of enterprises' logistics costs are spent on transportation. According to the investigation of National Council of Physical Distribution Management (NCPDM) in 1982 (Chang, 1988), the cost of transportation, on average, accounted for 6.5% of market revenue and 44% of logistics costs.

BTRE (2001) indicated that Australian gross value added of the transport and storage sector was \$34,496 million in 1999-2000, or 5.6% of GDP. Figure 3 shows the components of logistics costs based on the estimation from Air Transportation Association (Chang, 1988). This analysis shows transportation is the highest cost, which occupies 29.4% of logistics costs, and then in order by inventory, warehousing cost, packing cost, management cost, movement cost and ordering cost. The ratio is almost one-third of the total logistics costs. The transportation cost here includes the means of transportation, corridors, containers, pallets, terminals, labours, and time. This figure signifies not only the cost structure of logistics systems but also the importance order in improvement processing. It occupies an important ratio in logistics activities. The improvement of the item of higher operation costs can get better effects. Hence, logistics managers must comprehend transport system operation thoroughly.

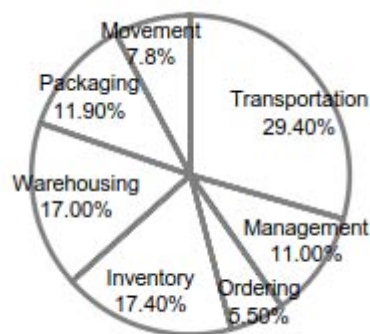

Figure 4. Cost ratio of logistics items (modified: Chang, 1998)

Transport system makes goods and products movable and provides timely and regional efficacy to promote value-added under the least cost principle. Transport affects the results of logistics activities and, of course, it influences production and sale. In the logistics system, transportation cost could be regarded as a restriction of the objective market. Value of transportation varies with different industries. For those products with small volume, low weight and high value, transportation cost simply occupies a very small part of sale and is less regarded; for those big, heavy and low-valued products, transportation occupies a very big part of sale and affects profits more, and therefore it is more regarded.

1.4.2 The Effects of Transportation on Logistics Activities

Transportation plays a connective role among the several steps that result in the conversion of resources into useful goods in the name of the ultimate consumer. It is the planning of all these functions and sub-functions into a system of goods movement in order to minimize cost maximize service to the customers that constitutes the concept of business logistics. The system, once put in place, must be effectively managed. (Fair et al., 1981)

Traditionally these steps involved separate companies for production, storage, transportation, wholesaling, and retail sale, however basically, production/manufacturing plants, warehousing services, merchandising establishments are all about doing transportation. Production or manufacturing plants required the assembly of materials, components, and supplies, with or without storage, processing and material handling within the plant and plant inventory.

Warehousing services between plants and marketing outlets involved separate transport. Merchandising establishments completed the chain with delivery to the consumers. The manufacturers limited themselves to the production of goods, leaving marketing and distribution to other firms. Warehousing and storage can be considered in terms of services for the production process and for product distribution. There have been major changes in the number and location of facilities with the closure of many single-user warehouses and an expansion of consolidation facilities and distribution centres. These developments reflect factors such as better transport services and pressures to improve logistics performance.

1.4.3 The Role of Transportation in Service Quality

The role that transportation plays in logistics system is more complex than carrying goods for the proprietors. Its complexity can take effect only through highly quality management. By means of well-handled transport system, goods could be sent to the right place at right time in order to satisfy customers' demands. It brings efficacy, and also it builds a bridge between producers and consumers. Therefore, transportation is the base of efficiency and economy in business logistics and expands other functions of logistics system. In addition, a good transport system performing in logistics activities brings benefits not only to service quality but also to company competitiveness.

1.5 Forms of Logistics Operation

1.5.1 Supply Chain Management

Supply Chain Management (SCM) is the concept for handling the production procedures in broad sense. An effective SCM application could promote the industry to satisfy the demand of new business environment. Ross (1998) defined SCM as 'a continuously evolving management philosophy that seeks to unify the collective productive competencies and resources of the business functions found both within the enterprise and outside in the firm's allied business partners located along intersecting supply channels into a highly competitive, customer-enriching supply system focused on developing innovative solutions and synchronizing the flow of marketplace products, services, and information to create unique, individualized sources of customer value.'

SCM can be divided into three main activities – purchase, manufacture and transport (Thomas et al., 1996). Cooper et al. (1997) analyzed the three elements of SCM – supply chain business processes, supply chain management components, and supply chain network structure. Figure

4 shows the entire elements in SCM frame. It displays the details of the whole processes from purchasing, management, production, and distribution to customers. The information flow is like an individual system to link the whole supply chain from supplier and manufacturer to consumer. Unimpeded information flow could increase the operation accuracy for costs saving and promote the competitiveness of firms. The product flow proceeds through the whole production processes from material supply via manufactories till providing the finished products to consumers. The items in vertical direction show the various management tasks within the supply chain. Particularly, the return flow, or reverse logistic, is one of the elements in the system but with converse direction from the others.

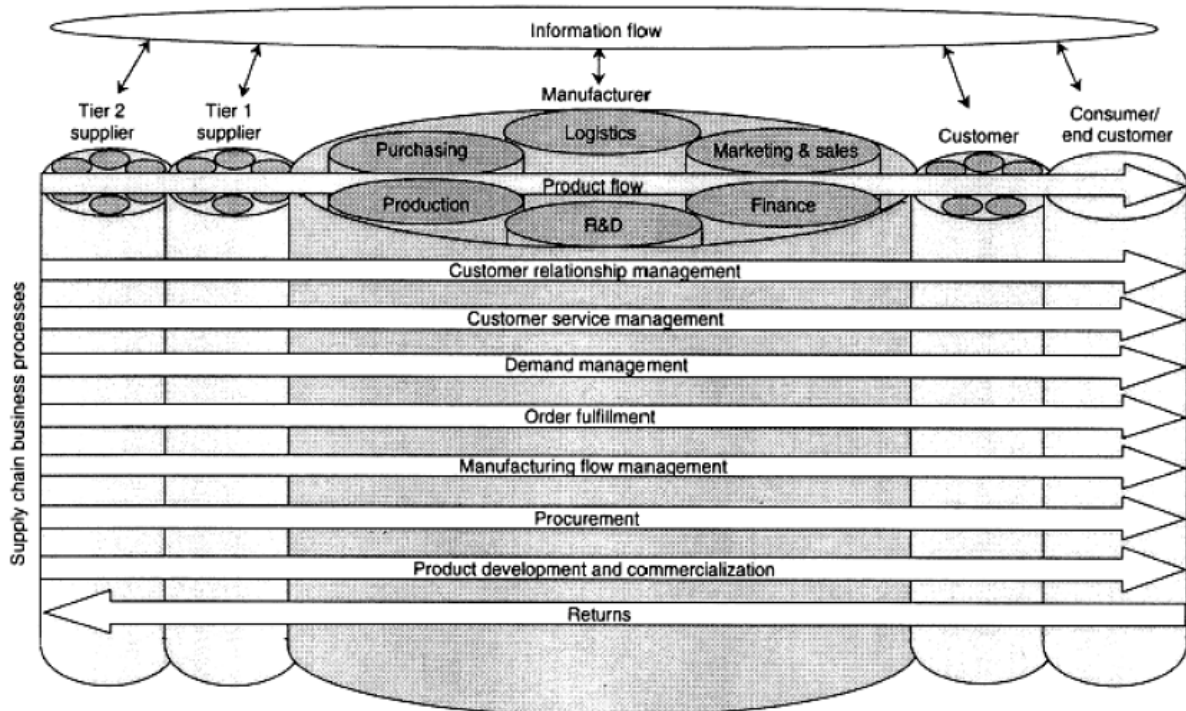

Figure 5. Interaction of business processes and supply chain (source: Cooper et al., 1997)

1.5.2 Reverse Logistics

The concept of reverse logistics has been applied in promoting customer service and resources recycling. Concerning quality control, the defective components and finished products will be returned to their producers through reverse logistics systems. Nowadays, reverse logistics has been developed rapidly for increasing industries' competitiveness, promoting customer service level, and recycling the reusable material. Meanwhile, the demand of reverse logistics brings out a new market for the third-party logistics industries.

Rogers et al. (1998) defined reverse logistics as 'the process of planning, implementing, and controlling the efficient, cost effective flow of raw materials, in- process inventory, finished goods and related information from the point of consumption to the point of origin for the purpose of recapturing value or proper disposal'. Figure 5 shows the structure of logistics systems, which includes forward logistics, backward logistics and information flow. The flow in black arrows presents the direction of reverse logistics, whose direction is counter to the ordinary logistics represented in hollow arrows. The information flow interlaces between different stakeholders within the system. Each stakeholder can communicate with the others

directly to maximum their profitability. Reverse logistics will be adopted in various modes and applications in the future due to its efficiency and benefits in environment protection.

The two main reasons behind the rise of reverse logistics are the globalization of markets and policies for environment protection. A successful reverse logistics could help to increase the service level of companies and reduce the costs of producing processes. More and more companies want to build their reverse logistics system. However, the system needs professional knowledge in logistics management and particular facilities. Thus, the third-party logistics service provides another option for small to middle size companies to have their reverse logistics system. Figure 6 shows a system of reverse logistics service on how FedEx, a third-party logistics provider, serves Acer computer, the customer company. At the first step of the system, the customer applies a request for returning the product through the Internet, and then FedEx builds the data of the products; meanwhile the system organizes the route of the delivery trips of the product. The customer can check the processing condition and wait for sending back at the right time.

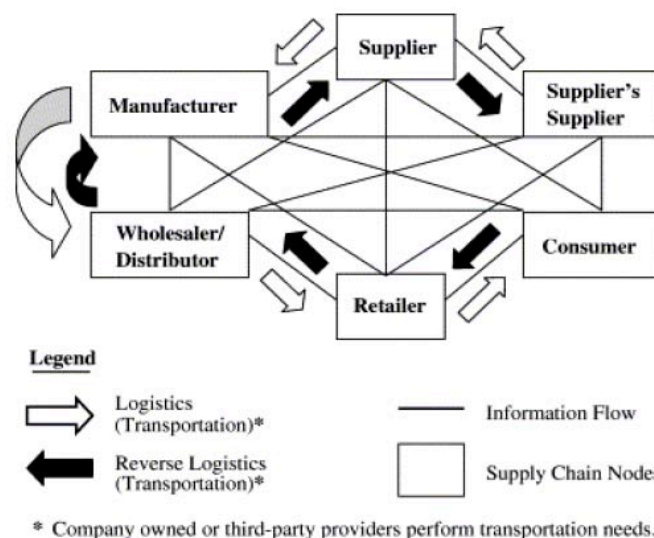

Figure 6. Consumer supply chain from, Krumwiede *et al.*, 2002

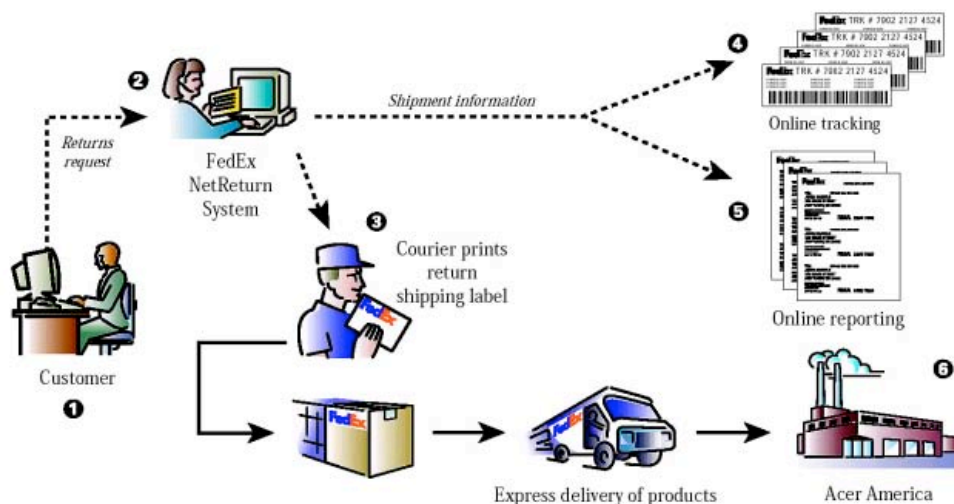

Figure 7. Third-party reverse logistics from, <http://www.fedex.com/us/solutions/downloads/acer.pdf>

1.5.3 Maritime Logistics

Maritime industry plays an important role in international freight. It can provide a cheap and high carrying capacity conveyance for consumers. Therefore, it has a vital position in the transportation of particular goods, such as crude oil and grains. Its disadvantage is that it needs longer transport time and its schedule is strongly affected by the weather factors. To save costs and enhance competitiveness, current maritime logistics firms tend to use large-scaled ships and cooperative operation techniques. Moreover, current maritime customers care about service quality more than the delivery price. Thus, it is necessary to build new logistics concepts in order to increase service satisfaction, e.g. real-time information, accurate time windows and goods tracking systems. The operation of maritime transport industry can be divided into three main types: (1) Liner Shipping: The business is based on the same ships, routes, price, and regular voyages. (2) Tramp Shipping: The characters of this kind of shipping are irregular transport price, unsteady transport routes, and schedule. It usually delivers particular goods, such as Dry Bulk Cargo and crude oil. (3) Industry Shipping: The main purpose of industry shipping is to ensure the supply of raw materials. This sometimes needs specialized containers, such as the high-pressure containers for natural gas.

1.5.4 Air Freight Logistics

Air freight logistics is necessary for many industries and services to complete their supply chain and functions. It provides the delivery with speed, lower risk of damage, security, flexibility, accessibility and good frequency for regular destinations, yet the disadvantage is high delivery fee. Reynolds-Feighan (2001) said air freight logistics is selected 'when the value per unit weight of shipments is relatively high and the speed of delivery is an important factor'. The characteristics of air freight logistics are that: (1) airplanes and airports are separated. Therefore, the industries only need to prepare planes for operation; (2) it allows to speed delivery at far destinations; (3) air freight transport is not affected by landforms.

Research data show that the freight transport market keeps growing. Given the trend of global markets, air freight logistics also has to change their services. The future tendencies of air freight development are integration with other transport modes and internationalization and alliance and merger between air transport companies the future pattern of air freight logistics is cooperative with other transport modes, such as maritime and land transport, to provide a service base on Just-In-Time, and door-to-door.

1.5.5 Land Logistics

Land logistics is a very important link in logistics activities. It extends the delivery services for air and maritime transport from airports and seaports. The most positive characteristic of land logistics is the high accessibility level in land areas. The main transport modes of land logistics are railway transport, road freight transport and pipeline transport.

Railway transport has advantages like high carrying capacity, lower influence by weather conditions, and lower energy consumption while disadvantages as high cost of essential facilities, difficult and expensive maintenance, lack of elasticity of urgent demands, and time consumption in organizing railway carriages. Road freight transport has advantages as cheaper investment funds, high accessibility, mobility and availability. Its disadvantages are low capacity, lower safety, and slow speed. The advantages of pipeline transport are high

capacity, less effect by weather conditions, cheaper operation fee, and continuous conveyance; the disadvantages are expensive infrastructures, harder supervision, goods specialization, and regular maintenance needs.

The excessive usage of land transport also brings many problems, such as traffic jams, pollution and traffic crashes. In the future, to improve the land transport in transport efficiency and reliability, a revolution of transport policies and management is required, e.g. pricing.

1.5.6 Express Delivery

As the increasing demand of time accuracy and decentralization of production, the need to reduce stock costs has led to the Just-In-Time (JIT) delivery principle, which involves more frequent delivery of materials at the right time and at the right place in the production process. The characteristics of express delivery are: (1) door-to-door service; (2) efficiency; (3) traceability; (4) Just-In-Time (JIT); (5) growing various delivery demands.

The trend toward increasingly compact products is expected to improve the cost-benefit ratio of express delivery by decreasing the transportation cost share. Smaller products will enlarge the market for express delivery services. Also, the increasing value of products requires rapid transportation, because companies want to reduce the interest costs bound up in stock and inventories. For future development, the industries should consider integrating the services with 24-hour stores so that customers could choose a certain shop as the pick-up station. Meanwhile, the services would become more efficient and controlled due to more regular routes to those shops instead of personal houses.

1.5.7 E-commerce

E-commerce is the future trend of business style. It brings many benefits for both companies and consumers: (1) E-commerce expands the market area from regional to global; (2) E-commerce uses electronic techniques instead of traditional paper works, which promotes the industries' efficiency and competitiveness; (3) The number of trips is increased. On the other hand the average load of single trip is reduced, which means it needs higher carriage if using the same means of transportation; (4) E-commerce will impact on transport system due to the increased trips; (5) E-commerce might reduce the number of warehouses and the stock cost. Therefore the prices could be lowered. Figure 7 and Figure 8 express the differences between the transport patterns of traditional trade and e-commerce. However other new topics, of course, accompany with the system and need to be concerned, such as Internet security, transport impacts and door-to-door services. A healthy and successful e-commerce environment is determined by the optimal logistics operation.

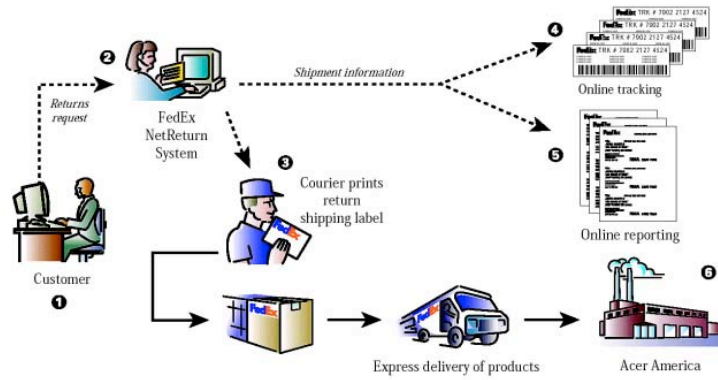

Figure 8. The transport pattern of traditional

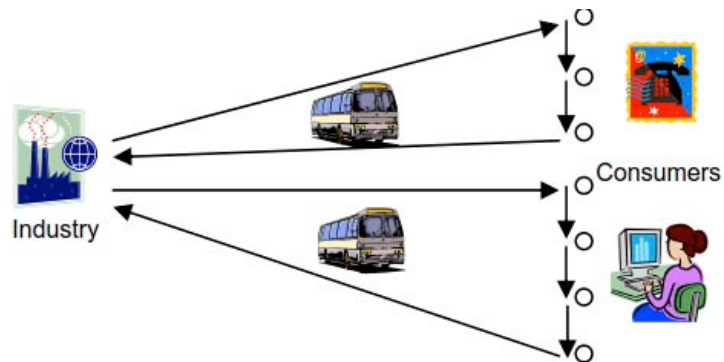

Figure 9. The transport pattern of e-commerce Business

2 INFRASTRUCTURES

This chapter will analyse terminal concepts in terms of the design, process organisation, layout, handling technology, IT and operations in Europe and the U.S.

2.1 Intermodal terminal concepts in Europe

As a matter of fact, there are various terminal concepts applied in Europe. The differences can be attributed to cultural, economic or historical reasons. In spite of that, during the last 10 to 15 years, one terminal concept providing common or very similar features has become more and more popular across Europe. This particular concept can be characterised as follows:

The terminals are built “around” a handling area ensuring the transfer between road and rail. This handling area is best described as a module which can be multiplied if more capacity were to be required. The handling area, with capacity to handle an annual volume of 120,000-150,000 units, typically has the following components (see Figure 11):

- 4 tracks of each 600 – 700 m (2,000 – 2,300 ft)
- 1 driving lane and 1 loading/unloading lane for lorries
- 3-4 intermediate storage lanes
- 2 rail-mounted gantry cranes over all tracks and lanes
- Additionally, the terminals provide for 2-4 arrival/departure tracks adjacent to the facility or at nearby marshaling yards or rail stations.

European rail/road terminals are used to allow all lorries entering the handling area. They consequently also carry out live-lifts between lorry and train. The check-in/check-out is usually a manual gate with desk service for drivers. There are few exceptions with semi-automated clearance processes.

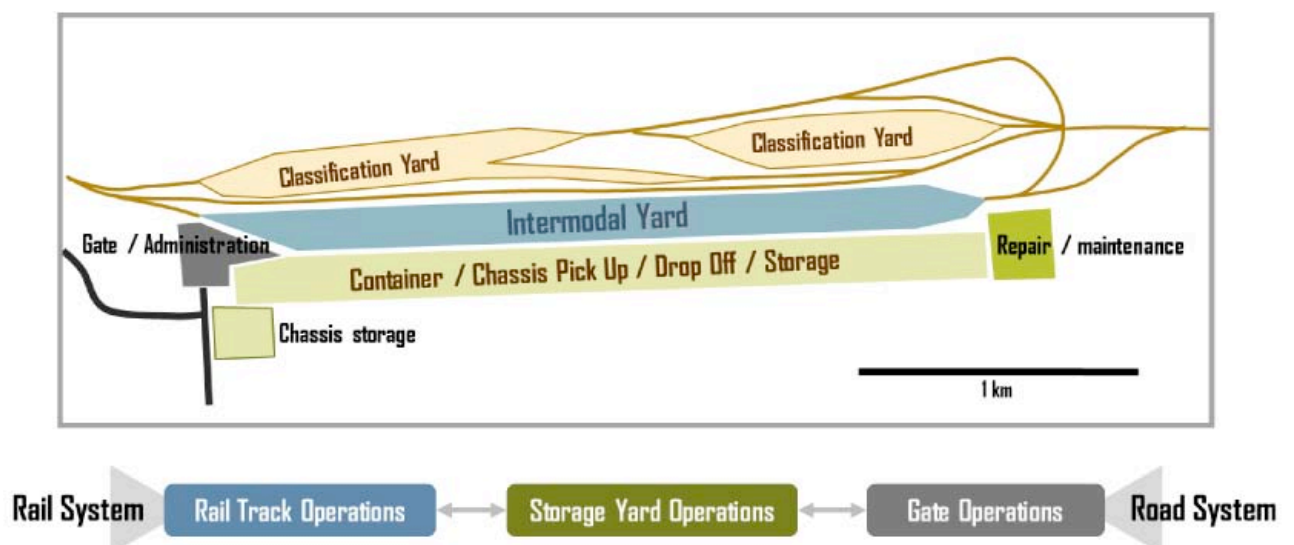

Figure 10. Bedford Yard in Chicago

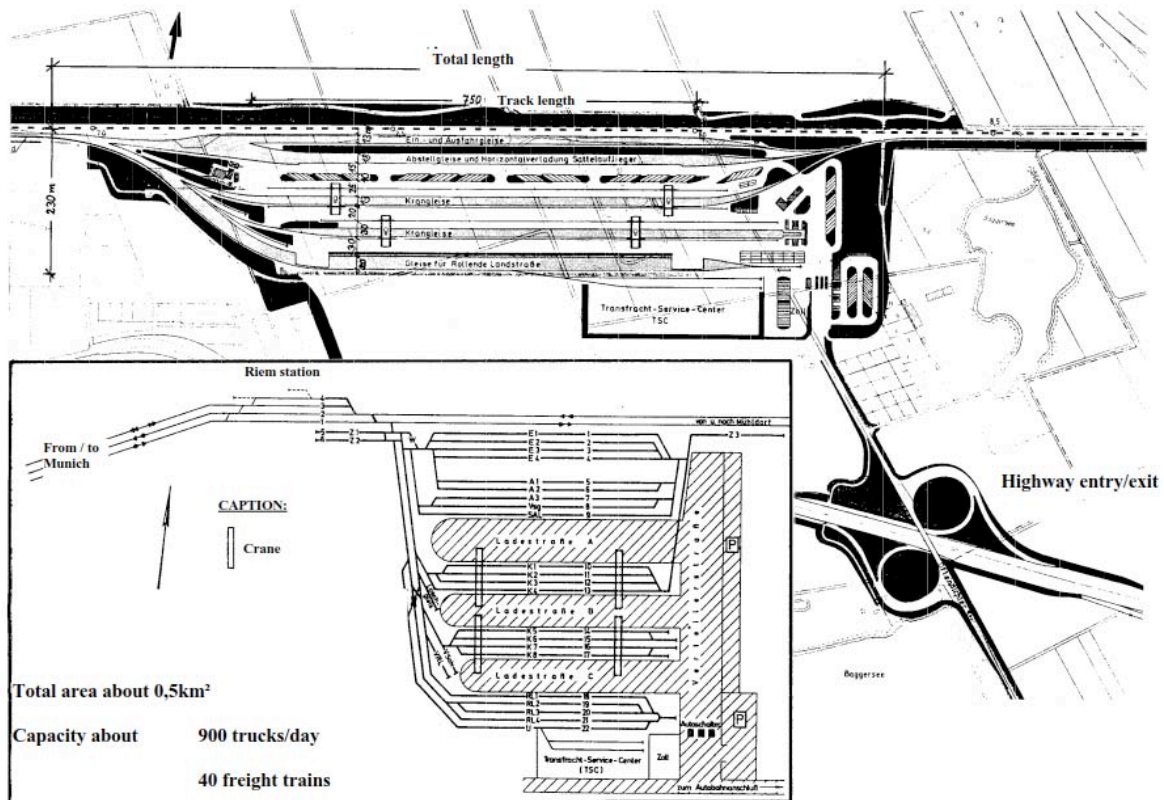

Figure 11. Transshipment station for intermodal transport, from Munich Riem station.

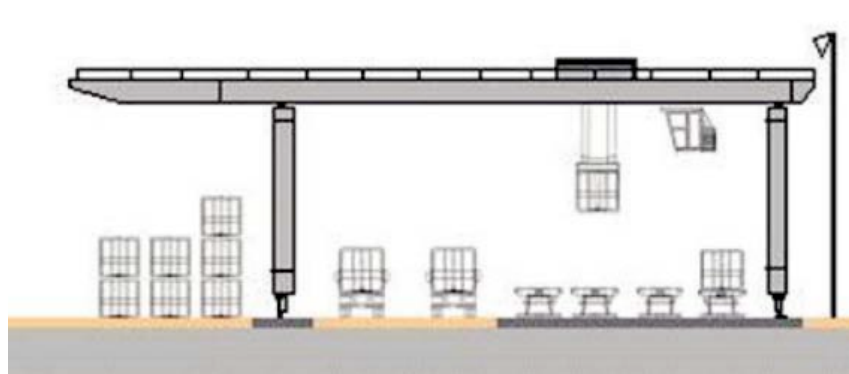

Figure 12. Typical terminal concept in Europe: cross-section.

2.2 Terminal design, process organisation and equipment in the U.S.

- U.S. intermodal terminals are usually built to a basic standard concept all over the country and vary virtually only in capacity and size. What largely determines the layout of terminals are the distinctive process organisation and handling technologies generally deployed:
- All lorries delivering outbound intermodal units must run through a strict check-in process at the in-gate. The same applies for the out-gate clearance if a lorry has picked up a shipment for road delivery.

- Intermodal terminals in the U.S. are characterised by the indirect handling of intermodal units. Lorry- and rail-side operations are usually completely separated. The delivery lorries park the intermodal loading units for rail shipment in an interim parking area, and these units are subsequently transferred to the handling area by terminal vehicles. At some facilities, however, railways allow lorries to enter the handling area for direct or live-lift load transshipments. In most cases the railways block certain time-slots for the direct handling of intermodal units to avoid interferences with internal movements.
- Current U.S. terminals feature a wheel-based operation. Every intermodal loading unit is parked on wheels on the interim parking spot. This is self-evident for a trailer, but containers remain on the chassis used for their road conveyance. The complete set – container on chassis – is then taken by terminal tractors into the handling yard. No reach-stacker or fork-lift truck is required at the interim parking area. The prerequisite for this process organisation is that each intermodal customer is member of a chassis pool, uses one railway’s chassis pool, or has his own fleet of chassis delivered for use by the railway.
- The “heart” of the terminal, the handling yard, also features a standard design. The handling capacity of a facility is easily increased by multiplying the handling modules. Each includes the following components:
 - One handling track
 - One parking lane for the trailers and chassis-mounted containers to be transferred onto wagons
 - One driving lane for vehicles.
 - Mobile rubber-tyred gantry cranes (RTG) spanning the entire handling module to enforce the transshipment of units (see Figure 19).

Parking or support tracks for the intermediate parking of trainsets are also required. U.S. railways try to locate them adjacent to the terminal.

This terminal handling concept results in a typical layout adopted by all major railways and implemented at most intermodal terminals.

Table 1 Inland Port Characteristics

INLAND PORT CHARACTERISTICS	
EU	US
1) Terminals are built “around” a handling area ensuring the transfer between road and rail	1) Usually built to a basic standard concept and vary virtually only in capacity and size
2) Handling area, with capacity to handle an annual volume of 120,000-150,000 units	2) Largely determines the layout of terminals, the distinctive process organization and handling technologies
3) Usual Size	3) They are characterised by the indirect handling of intermodal units. Lorry- and rail-side operations are usually completely separated. Delivery lorries park the intermodal loading units for rail shipment in an interim parking area, and units are subsequently transferred to the handling area by terminal vehicles.
- 4 tracks of each 600 – 700 m (2,000 – 2,300 ft)	4) The “heart” of the terminal, the handling yard, also features a standard design. The handling capacity of a facility is easily increased by multiplying the handling modules
- 1 driving lane and 1 loading/unloading lane for lorries	- One handling track
- 3-4 intermediate storage lanes	- One parking lane for the trailers and chassis-mounted containers to be transferred onto wagons
- 2 rail-mounted gantry cranes over all tracks and lanes	- One driving lane for vehicles.
- Terminals provide for 2-4 arrival/departure tracks adjacent to the facility	- Mobile rubber-tyred gantry cranes (RTG) spanning the entire handling module to enforce transshipment of units
4) European rail/road terminals are used to allow all lorries entering the handling area	5) Parking or support tracks for the intermediate parking of trainsets are also required. U.S. railways try to locate them adjacent to the terminal
5) They consequently also carry out live-lifts between lorry and train	6) Every intermodal loading unit is parked on wheels on the interim parking spot.
6) The check-in/check-out is usually a manual gate with desk service for drivers	7) All lorries run through a strict check-in process at the in/out gate
	8) This terminal handling concept results in a typical layout adopted by all major railways and implemented at most intermodal terminals



Figure 13. UP intermodal terminal ICTF Los Angeles (CA): aerial and cross-section, from Port of Los Angeles.

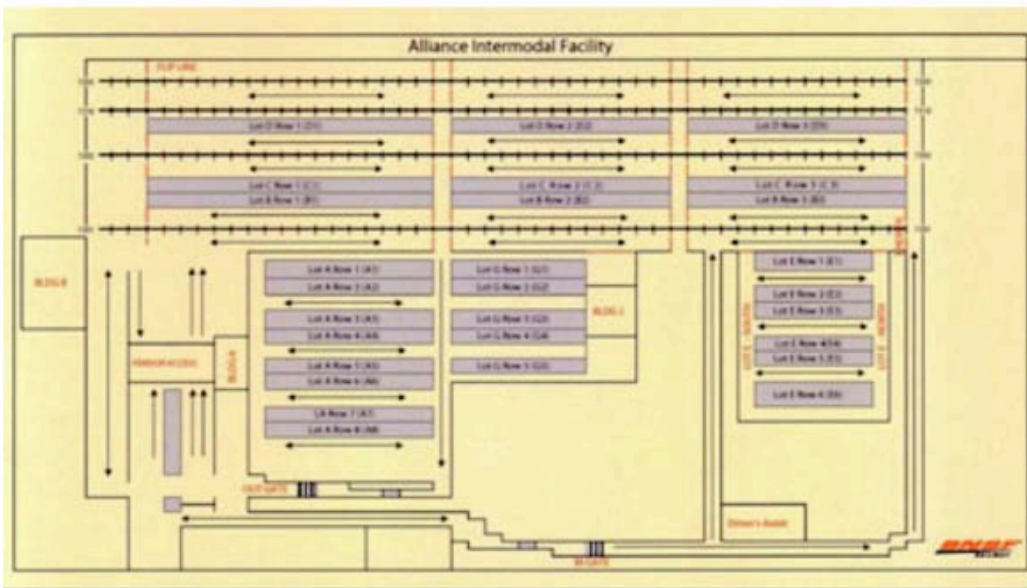

Figure 14. BNSF intermodal terminal Alliance (TX): aerial and layout map, from BNSF

2.3 Recent developments in terminal design and equipment

In recent years, this well-proven terminal concept has been put on trial. Interestingly, the decisive impulse came from administrations especially of U.S. west-coast states such as California or Washington. California is also known in Europe for pursuing a rather independent environmental policy, which now extends to rail freight and intermodal traffic. The U.S. states have determined a set of environmental objectives for example with respect to air pollution, noise or land use, which have to be complied with a specified timeframe. In order to match these environmental objectives e.g. in Los Angeles or Seattle, the U.S. railways were required to re-design terminals. The result of the process of re-thinking terminal layout and process organisation is shown by two examples from Los Angeles in Figures 50-51. Both the building of BNSF’s new facility and the complete re-construction of UP’s twenty-year-old ICTF terminal must be

finalised during the next few years. The new terminal concepts are characterised as follows:

To match the air-pollution objective, the railways have been forced to shift from diesel-driven handling equipment to electrically-powered rail-mounted gantry cranes (RMG), and reduce or even eliminate terminal-internal tractor movements. These prerequisites have led to a terminal concept featuring a fairly compact layout of handling modules composed of wide-span cantilever gantry cranes and a set of handling tracks under the crane portal.

Basically, the indirect process organisation shall be maintained. However, lorries will now have direct access to cranes. Trailers can be parked under the cantilevers of gantry cranes, while the new concept provides an interim storage area for containers under the portal. Containers can even be stacked, which raises the efficiency of land use and also contributes to improving the environmental footprint of intermodal traffic. Owing to the direct access of trucks to handling, yard live-lifts can also be carried out.

The BNSF facility features so-called nested gantry cranes. They perform the transfer between lorries and interim storage space for containers. The large gantry cranes move the container between this area and the wagons. Live lifts can also be performed off the backside cantilever. However, what in the first place was driven by environmental objectives can also improve the economics of intermodal traffic. According to BNSF experts, these objectives will translate into a 20% minimum saving on investment and a saving in excess of 20% through application of the new terminal concept. Against this background, BNSF is set to install this concept not only in west-coast sea ports such as Seattle and Los Angeles where environmental policy is rather strict, but also at inland terminals like Memphis or Kansas City.

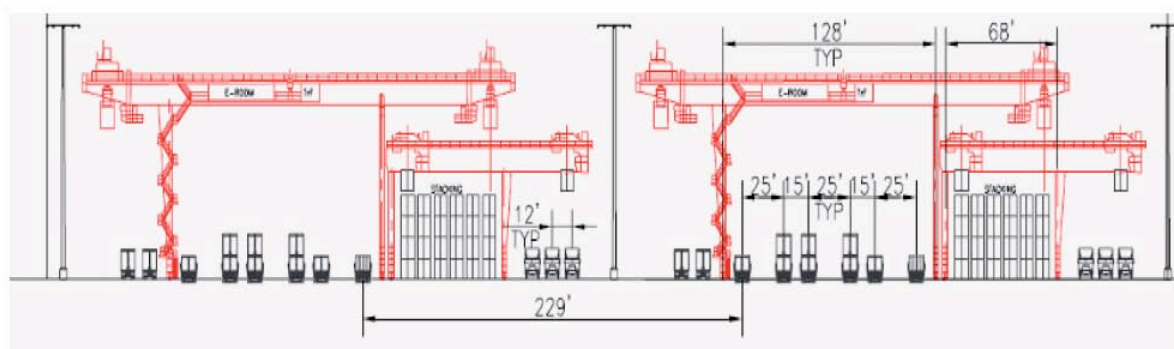

Figure 15. BNSF terminal Southern California International Gateway (SCIG) in Los Angeles (CA): cross-section of facility, from Port of Los Angeles.

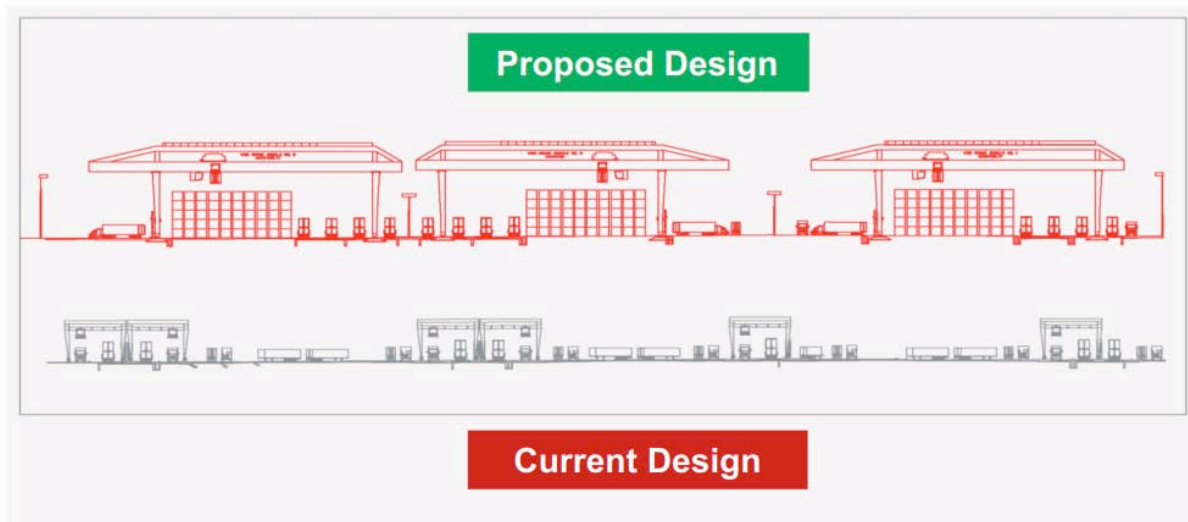

Figure 16. Redesign of UP's intermodal terminal ICTF Los Angeles (CA), from Port of Los Angeles.

2.4 Infrastructure

2.4.1 Warehouses

Warehouses are created at container terminals to hold specific goods that are transported to the port but are not being shipped out in the same container. This style of transport is not common; however, this can be service supplied by the terminal owners to increase imports. Those goods, when warehoused, incur additional handling and storage costs increasing revenue as well.

2.4.2 Container Lay Down Area

A lay down area is the vast amount of space where container handling equipment place full or empty containers prior to loading onto the containers' next step in its journey to its destination. The lay down area is composed of multiple structural layers to support the loads brought on by the equipment and cargo.



Figure 17. Container lay down area, from <http://www.metrans.eu/terminal-operations/rail-hub-terminal-prague-uhrineves-cz/> .

The lay down area surface is also designed for multiple functions. The pavement must drain towards a drainage system as well as have a sufficient grip to prevent skidding. Finally, the pavement is painted to show lanes for travel as well as rows to place Intermodal container containers when not in transit.

2.4.3 Intermodal Yard

Intermodal yard are mainly consisted of two parts, rail yards and container storage yards. Rail yards should have access to rails and container storage yards should have access to trucks. Container storage yards include yards for inbound containers with cargo and internal movements, yards for outbound containers with cargo, yards for trans-shipment containers and yards for empties. The area requirements are measured in TEU ground slots (the area required for one 20-ft container) plus operating space for equipment that transfers containers to and from the yards and that stack and deliver containers.

2.4.4 Customs facility

Customs should have both base offices at the warehouse and around the gates. The office at the warehouse is mainly for detecting harmful agriculture and smuggling. Office at gates are mainly for the reason of detecting mis-picked cargo or radiation containers. At gates, there should be radiation-detection equipment aim at detecting dangerous weapons and radiation stuff that can be used to make dirty bombs. Radiation Portal Monitors (RPMs) are passive radiation detection devices used for the screening of individuals, vehicles, cargo or other vectors for detection of illicit sources such as at borders or secure facilities.

2.5 Container Handling Equipment

Handling equipment can be designed with intermodality in mind, assisting with transferring containers between rail, road and sea. These can include:

- **Rail Mounted Gantry Crane (RMGC)** consist of a supporting framework that can traverse the length of a quay or yard on a rail track. Instead of a hook, they are equipped with a specialized handling tool called a spreader. The spreader can be lowered on top of a container and locks onto the container's four locking points ("corner castings") using a twistlock mechanism. Cranes normally transport a single container at once, but some newer cranes have the capability to pick up two to four 20-foot containers at once.



Figure 18. Rail Mounted Gantry Crane (RMG), from <https://www.liebherr.com/en/rou/products/maritime-cranes/port-equipment/rail-mounted-stacking-cranes/rail-mounted-gantry-cranes.html> .



Figure 19. Rail Mounted Gantry Crane (RMG), from <http://www.konecranes.com/equipment/container-handling-equipment/rail-mounted-gantry-cranes>

- **Rubber tyred gantry cranes (RTG)**, smaller gantry cranes are also available running on rubber tyres so that tracks are not needed. They are used to move and straddle multiple lanes of rail, road, or container storage. They also are capable of lifting fully loaded containers to great heights. Smaller rubber tyred gantry cranes come in the form of straddle carriers which are used when moving individual containers or vertical stacks of containers.

Portable gantry crane systems, such as rubber tyred gantry cranes, are in high demand in terminals and ports restricted in size and reliant on maximizing vertical space and not needing to haul containers long distances. This is due to the relatively slow speed yet high reach of rubber tyred gantry cranes when compared to other forms of container terminal equipment

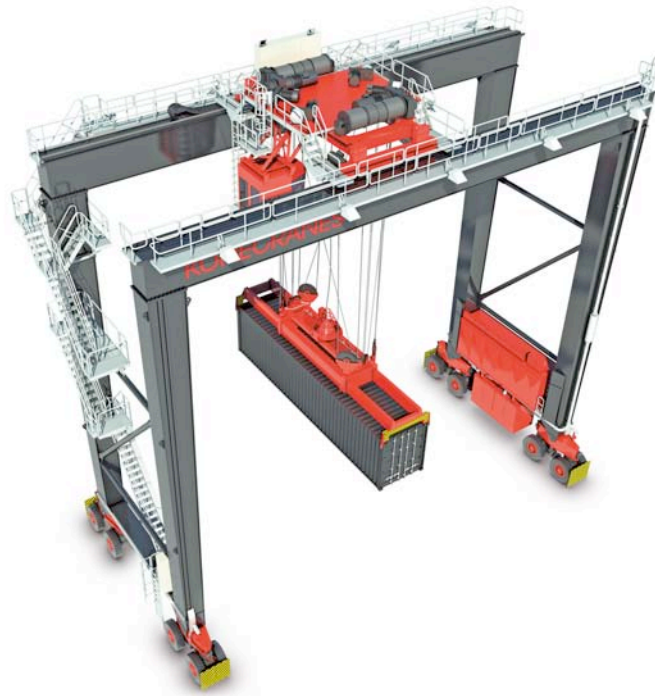

Figure 20. Rubber Tired Gantry Crane (RTG), from <http://www.konecranes.com/equipment/container-handling-equipment/rubber-tired-gantry-cranes> .

- **Straddle carriers**, and the larger rubber tyred gantry crane are able to straddle container stacks as well as rail and road vehicles, allowing for quick transfer of containers.



Figure 21. Straddle Carrier, from <http://www.konecranes.com/equipment/container-handling-equipment/straddle-carriers>.

Inter-modal container transport facilities used for storage areas such as Reach Stackers, Tractor-Trailer Units (TTUs) and Vehicles.

- A **reach stacker** is a vehicle used for handling intermodal cargo containers in small terminals or medium-sized ports. Reach stackers are able to transport a container short distances very quickly and pile them in various rows depending on its access.

Reach stackers have gained ground in container handling in most markets because of their flexibility and higher stacking and storage capacity when compared to forklift trucks. Using reach stackers, container blocks can be kept 4-deep due to second row access.

There are also empty stackers or empty container handlers that are used only for handling empty containers quickly and efficiently.



Figure 22. Reach Stackers, from <http://www.konecranes.com/equipment/lift-trucks/reach-stackers> .

Parameters for cranes and inter-modal cargo transport facilities considered in detailed design are: quantities, size limit, power requirement, handling capacity, handling speed, cost, load to land limit, and other working environment constraints.

The deployment of equipment shall be designed with a key mission to create enough cargo transportation to balance the cargo flow. Queueing theory shall be introduced to the quantity and quality of equipment required.



Figure 23. Container Lift Trucks, from <http://www.konecranes.com/equipment/lift-trucks/container-lift-trucks>.

- **Sidelifters** are a road-going truck or semi-trailer with cranes fitted at each end to hoist and transport containers in small yards or over longer distances.



Figure 24. Sidelifter, from <http://www.konecranes.com/equipment/lift-trucks/reach-stackers>

- **Forklift trucks** in larger sizes are often used to load containers to/from truck and rail.



Figure 25. A straight mast container handler at Haikou Xiuying Port, Hainan, China, from https://en.wikipedia.org/wiki/Forklift#/media/File:Straight_mast_container_handler_02.jpg.

Flatbed trucks with special chain assemblies such as QuickLoadz can pull containers onto or off of the bed using the corner castings.

2.6 Customer's intermodal "life cycle"

This section explains, from the customer perspective, the processing or "life cycle" of an intermodal shipment at intermodal terminals in the U.S.

The central IT reservation systems are actually the "heart" of intermodal traffic with all major U.S. railways. This ensures an efficient management of all processes related to shipping intermodal units and, in particular, accelerates terminal procedures while guaranteeing a very high level of safety and security. Any shipment for carriage by an intermodal service, must be booked with the railway in question. Railways attempt to convince their customers to book electronically. According for example to Norfolk Southern officials, 95 % of all bookings are processed via electronic data interchange (EDI) today. Those customers who continue to book via fax are billed an extra fee, which is justified given the additional cost entailed.

A delivery lorry arriving at a terminal with an intermodal shipment, which has not been booked, will not be cleared at the check-in-gate. Either the lorry must leave immediately, or the driver is ushered to a help desk where he/she can clarify the issue with the company which ordered him/her. U.S. railways also recommend advance-submission of the bill of lading (waybill) electronically. At some terminals, there are "fast tracks" ensuring an accelerated clearing process for those lorries. On the other hand, the check-in process requires more time if drivers provide a paper version of the bill of lading.

The check-in process includes the following procedures:

1. check of bill of lading and other documents, if applicable;
2. cross-check of booked versus actual equipment (container, trailer) identity;
3. registering of chassis identity, if applicable;
4. damage inspection of equipment, inspection of seals;
5. instructions for the driver as to which parking lot he/she shall take the intermodal shipment.

Usually the railways do not check immediately whether the driver has deposited the equipment on the right spot. The driver of the terminal tractor who brings the shipment to the handling yard must however cross-check with the database.

During the last 20 years, the U.S. railways have heavily invested in state-of-the-art technology to improve and accelerate the gate clearance process. Since about ten years, virtually all new terminals are fitted with Automated Gate Systems (AGS), and older facilities are being modernised in this respect. Even if the systems in operation are different, they have common features as follows (Figures 25 & 26):

1. Lorry drivers do not have to leave their vehicles anymore. Based on advanced booking data – as a prerequisite - they proceed directly to check-in posts equipped with special computers with screen and simplified keyboard, plus a microphone. This is the only connection to the gate house, where an operator is charged with controlling and managing all processes and eventually communicating with drivers.
2. To start the clearance process, drivers typically must indicate a booking reference code and the identity code of the intermodal unit to be shipped.
3. Damage inspection and identification of shipments are carried out automatically. Lorries drive through a camera portal designed to record damage to the equipment. Nowadays OCR (optical character recognition) cameras are frequently installed as well. The

software application is able to “read” the identity code of containers, trailers and chassis automatically. The rate of correct readings is claimed to be 85 to 95 %. The operator, however, obtains the pictures from the video cameras and is thus able to cross-check the results provided by the OCR-based software.

4. When the shipment has been cleared, a paper slip will be printed containing information on the parking lot to which the shipment should be driven.



Figure 26. Automated Gate System: driver clearance post,



Figure 27. Automated Gate Systems at CN intermodal facility in Brampton, from CN International.

2.7 Size of intermodal terminals

In Europe, large intermodal terminals handle about 200,000 to 300,000 units annually. In the U.S., there are many facilities handling between 250,000 and 500,000 units per year. The largest terminals are in the “hot spots” of American intermodal traffic, in Chicago and Los Angeles. BNSF’s largest terminal actually is in L.A. with an annual capacity of about 1.5 million lifts. Figure 55 represents the top-ranking terminals of Union Pacific showing that eight of ten terminals are in the range of the biggest European terminals.

Over the last few years, the U.S. railways have tended to build large and central terminals in key economic centres called “megapolitan areas” and close to smaller sites, the aim being to boost the efficiency of rail transport. According to customers, the effect of this policy is that road distances to terminals have increased and drayage costs reached a comparatively high ratio. This evolution is regarded as critical since it might raise the resistance to using intermodal services.

Table 2. Handling volume of Union Pacific’ major intermodal terminals: 2007

Top 10 Intermodal Terminals	Annual Lifts 2007
ICTF (Los Angeles), California	719,000
Marion (Memphis), Tennessee	414,000
East Los Angeles, California	360,000
Global II (Chicago), Illinois	353,000
Global I (Chicago), Illinois	310,000
Dallas, Texas	292,000
Seattle, Washington	250,000
Yard Center (Chicago), Illinois	238,000
Oakland, California	236,000
Englewood (Houston), Texas	214,000

Source: UP website

3 CONTAINER & EQUIPMENT

This chapter will present container types and analyse technical aspects of container in Europe and the U.S. and container carriers.

3.1 Container

Containers, also known as intermodal containers or ISO containers because the dimensions have been defined by ISO, are the main type of equipment used in intermodal transport. The twenty-foot equivalent unit (often TEU or teu) is an inexact unit of cargo capacity often used to describe the capacity of container ships and container terminals. It is based on the volume of a 20-foot-long (6.1 m) intermodal container, a standard-sized metal box which can be easily transferred between different modes of transportation, such as ships, trains and trucks.

According to ISO standards, there are five common standard lengths:

1. 20 ft (6.10 m)
2. 40 ft (12.19 m)
3. 45 ft (13.72 m)
4. 48 ft (14.63 m)
5. 53 ft (16.15 m)



Figure 28. Commonly used container lengths, from <https://commons.wikimedia.org/w/index.php?curid=41113427>.

Table 3. TEU capacities

TEU capacities for common container sizes				
Length	Width	Height	Volume	TEU
20 ft (6.1 m)	8 ft (2.44 m)	8 ft 6 in (2.59 m)	1,360 cu ft (38.5 m ³)	1
40 ft (12.2 m)	8 ft (2.44 m)	8 ft 6 in (2.59 m)	2,720 cu ft (77 m ³)	2
45 ft (13.7 m)	8 ft (2.44 m)	8 ft 6 in (2.59 m)	3,060 cu ft (86.6 m ³)	2 or 2.25
48 ft (14.6 m)	8 ft (2.44 m)	8 ft 6 in (2.59 m)	3,264 cu ft (92.4 m ³)	2.4
53 ft (16.2 m)	8 ft (2.44 m)	8 ft 6 in (2.59 m)	3,604 cu ft (102.1 m ³)	2.65
High cube				
20 ft (6.1 m)	8 ft (2.44 m)	9 ft 6 in (2.90 m)	1,520 cu ft (43 m ³)	1
Half height				
20 ft (6.1 m)	8 ft (2.44 m)	4 ft 3 in (1.30 m)	680 cu ft (19.3 m ³)	1

The three common sizes are:

- one TEU - 20 feet (6.1 m) x 8-foot (2.4 m) x 8-foot-6-inch (2.59 m)

General Purpose Container

20'

ISO Size Type Code: 22G0, 22G1



General Purpose Container

20'

Construction	Inside Dimensions			Door Opening		Weights			Capacity m ³ cu.ft	Hapag-Lloyd Serial Number	Foot- note
	Length	Width	Height	Width	Height	Max. Gross kg lbs	Tare kg lbs	Max. Payload kg lbs			
8'6" high	mm ft	mm ft	mm ft	mm ft	mm ft						
Steel container with corrugated walls and wooden floor	5 895 19'4 1/8"	2 350 7'8 1/2"	2 392 7'10 1/8"	2 340 7'8 1/8"	2 292 7'6 1/4"	30 480 67 200	2 250 4 960	28 230 62 240	33.2 1172	CPSU 100 000 - 108 362 CPSU 108 470 - 182 089 VLU 955 076 - 957 000 HLXU 200 000 - 212 799 HLXU 212 800 - 239 799 HLXU 300 000 - 310 089	1) 2) 3) 1) 2) 3)
	5 900 19'4 1/4"	2 352 7'8 5/8"	2 395 7'10 1/4"	2 340 7'8 1/8"	2 292 7'6 1/4"	32 500 71 650	2 370 5 220	30 130 66 430	33.2 1172	HLXU 310 100 - 340 699 HLXU 340 800 - 354 699	1) 2) 3) 1) 2) 3)
and steel floor	5 895 19'4 1/8"	2 350 7'8 1/2"	2 392 7'10 1/8"	2 340 7'8 1/8"	2 292 7'6 1/4"	32 500 71 650	2 570 5 670	29 930 65 980	33.2 1172	HLXU 340 700 - 340 799 CPSU 108 363 - 108 468	1) 2) 3) 3)
Construction	Inside Dimensions				Weights			Capacity m ³ cu.ft	Hapag-Lloyd Serial Number	Foot- note	
	Length	Width	Height		Max. Gross kg lbs	Tare kg lbs	Max. Payload kg lbs				
8'6" high ISO Size Type Code: 22U6	mm ft	mm ft	Middle mm ft	Side mm ft							
Steel container with corrugated walls, wooden floor and removable steel roof	5 886 19'3 3/4"	2 342 7'8 1/8"	2 388 7'10"	2 313 7'7"	30 480 67 200	2 700 5 950	27 780 61 250	32.8 1160	FANU 260 200 - 261 799	4)	
	5 886 19'3 3/4"	2 342 7'8 1/8"	2 388 7'10"	2 313 7'7"	30 480 67 200	2 700 5 950	27 780 61 250	32.8 1160	HLXU 365 000 - 365 649	4)	
	5 859 19'3 1/4"	2 350 7'8 1/8"	2 390 7'9 1/2"	2 309 7'7 1/2"	32 500 71 650	2 850 6 280	29 650 65 370	32.1 1132	HLXU 365 650 - 365 949	4)	

Figure 29. 20 feet container, from <https://www.hapag-lloyd.com/en/products/fleet/container.html>.

- two TEU - 40 feet (12 m) x 8-foot (2.4 m) x 8-foot-6-inch (2.59 m)

General Purpose Container

40'

ISO Size Type Code: 42G0, 42G1



General Purpose Container

40'

Construction	Inside Dimensions			Door Opening		Weights			Capacity m ³ cu.ft	Hapag-Lloyd Serial Number	Foot- note
	Length	Width	Height	Width	Height	Max. Gross kg lbs	Tare kg lbs	Max. Payload kg lbs			
8'6" high	mm ft	mm ft	mm ft	mm ft	mm ft						
Steel container with corrugated walls and wooden floor	12 029 39'5 1/4"	2 350 7'8 1/2"	2 392 7'10 1/4"	2 340 7'8 1/4"	2 292 7'6 1/4"	30 480 67 200	3 780 8 330	26 700 58 870	67,7 2 390	CPSU 400 000 – 475 275 HLXU 400 000 – 449 999 HLXU 500 000 – 507 749 HLXU 509 750 – 510 249	
	12 032 39'5 1/4"	2 352 7'8 3/4"	2 395 7'10 1/4"	2 340 7'8 1/4"	2 292 7'6 1/4"	32 500 71 650	4 030 8 885	28 470 62 765	67,7 2 390	HLXU 507 750 – 509 749 HLXU 510 250 – 542 999	

Construction	Inside Dimensions				Weights			Capacity m ³ cu.ft	Hapag-Lloyd Serial Number	Foot- note
	Length	Width	Height		Max. Gross kg lbs	Tare kg lbs	Max. Payload kg lbs			
			Middle mm ft	Side mm ft						
8'6" high ISO Size Type Code: 42U6	mm ft	mm ft	mm ft	mm ft						
Steel container with corrugated walls, wooden floor and removable steel roof	12 020 39'5 1/4"	2 342 7'8 1/4"	2 388 7'10"	2 313 7'7"	30 480 67 200	4 700 10 360	25 780 56 840	67,2 2 374	FANU 462 100 – 462 399	3)
	12 020 39'5 1/4"	2 342 7'8 1/4"	2 388 7'10"	2 313 7'7"	30 480 67 200	4 700 10 360	25 780 56 840	67,2 2 374	FANU 462 400 – 463 999 HLXU 465 000 – 466 249	3)
	12 020 39'5 1/4"	2 345 7'8 1/4"	2 380 7'9 1/4"	2 300 7'6 1/2"	30 480 67 200	4 700 10 360	25 780 56 840	65,3 2 306	HLXU 467 950 – 467 999	3)

Figure 30. 40 feet container, from <https://www.hapag-lloyd.com/en/products/fleet/container.html>.

- highcube-40 feet (12 m) x 8-foot (2.4 m) x 9-foot-6-inch (2.90 m)

High Cube General Purpose Container

40'

ISO Size Type Code: 45G0, 45G1

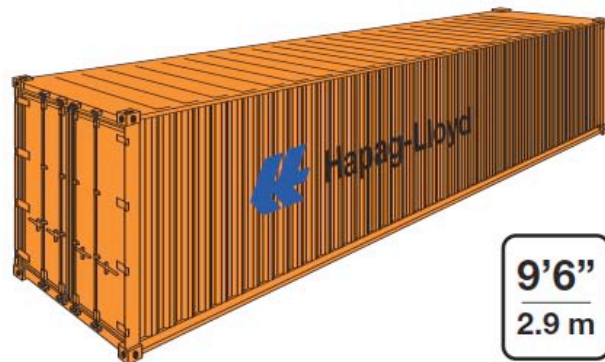

High Cube General Purpose Container

40'

Construction	Inside Dimensions			Door Opening		Weights			Capacity m ³ cu.ft	Hapag-Lloyd Serial Number	Foot- note
	Length	Width	Height	Width	Height	Max. Gross kg lbs	Tare kg lbs	Max. Payload kg lbs			
9'6" high	mm ft	mm ft	mm ft	mm ft	mm ft						
	12 024 39'5¼"	2 350 7'8½"	2 697 8'10¼"	2 340 7'8¼"	2 597 8'6¼"	30 480 67 200	4 020 8 860	26 460 58 340	76,3 2 694	HLXU 450 000 - 459 599 HLXU 633 600 - 635 399	
	12 032 39'5¾"	2 350 7'8½"	2 699 8'10¼"	2 340 7'8¼"	2 597 8'6¼"	30 480 67 200	4 000 8 818	26 480 58 378	76,3 2 694	HLXU 600 000 - 627 099 HLXU 631 100 - 631 799 CPSU 600 000 - 648 568	
Steel container with corrugated walls and wooden floor	12 032 39'5¾"	2 352 7'8½"	2 700 8'10¼"	2 340 7'8¼"	2 597 8'6¼"	32 500 71 650	4 010 8 840	28 490 62 810	76,3 2 694	HLXU 627 100 - 631 099 HLXU 631 800 - 633 599 HLXU 635 400 - 655 899 HLXU 656 000 - 659 899	
and steel floor	12 032 39'5¾"	2 352 7'8½"	2 700 8'10¼"	2 340 7'8¼"	2 597 8'6¼"	32 500 71 650	4 460 8 840	28 040 62 810	76,3 2 694	HLXU 655 900 - 655 999	

Construction	Inside Dimensions				Weights			Capacity m ³ cu.ft	Hapag-Lloyd Serial Number	Foot- note
	Length	Width	Height		Max. Gross kg lbs	Tare kg lbs	Max. Payload kg lbs			
9'6" high ISO Size Type Code: 45U6	mm ft	mm ft	Middle mm ft	Side mm ft						
	12 020 39'5¼"	2 342 7'8¼"	2 693 8'10"	2 618 8'7"	30 480 67 200	4 900 10 803	25 580 56 394	75,8 2 677	HLXU 665 100 - 665 199 HLXU 467 000 - 467 299	1) 1)
Steel container with corrugated walls, wooden floor and removable steel roof	12 020 39'5¼"	2 342 7'8¼"	2 693 8'10"	2 618 8'7"	32 500 71 650	5 200 11 436	27 300 60 180	76,0 2 684	HLXU 665 200 - 666 849	1)

Figure 31. 40 feet high cube container, from <https://www.hapag-lloyd.com/en/products/fleet/container.html>.

In countries where the railway loading gauge is sufficient, truck trailers are often carried by rail.

Other container types are presented below:

- Open-topped version is covered by a fabric curtain and is used to transport heavy loads and over-sized cargo as well as project cargo.

Open Top Container

20'

ISO Size Type Code: 22U1



Figure 32. 20 feet open top container, from <https://www.hapag-lloyd.com/en/products/fleet/container.html>.

Open Top Container

40'

ISO Size Type Code: 42U1



Figure 33. 40 feet open top container, from <https://www.hapag-loyd.com/en/products/fleet/container.html>.

Roof and door openings of Open Top Containers

20', 40'

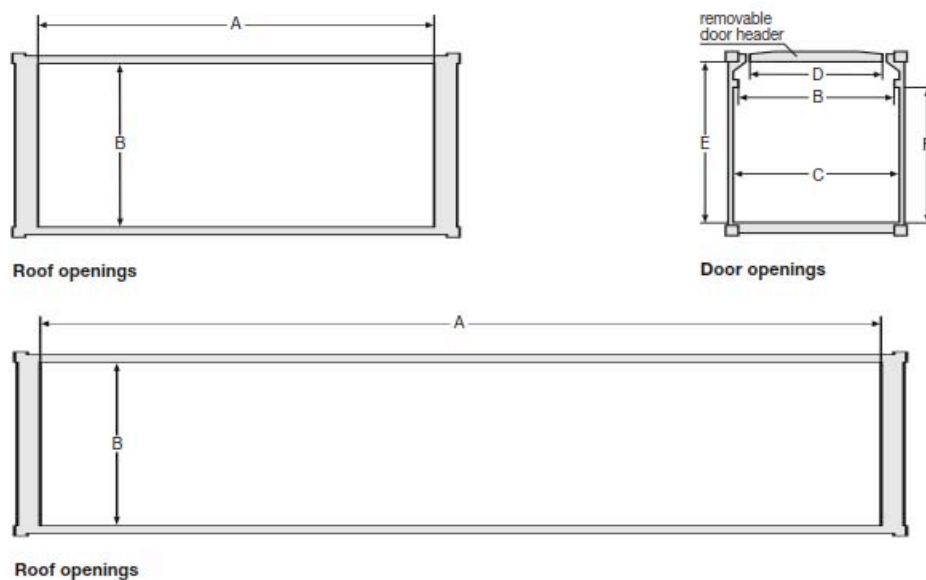

Figure 34. Roof and door openings for 20 & 40 feet open top containers, from <https://www.hapag-loyd.com/en/products/fleet/container.html>.

- Flat version is used to transport heavy loads (including timber) and over-sized cargo as well as project cargo.

Flat - All Types

20'

ISO Size Type Code: 8'6" high, 22P3, 22P8



Figure 35. 20 feet flat container, from <https://www.hapag-lloyd.com/en/products/fleet/container.html>.

High Cube Flat

40'

ISO Size Type Code: 45P8

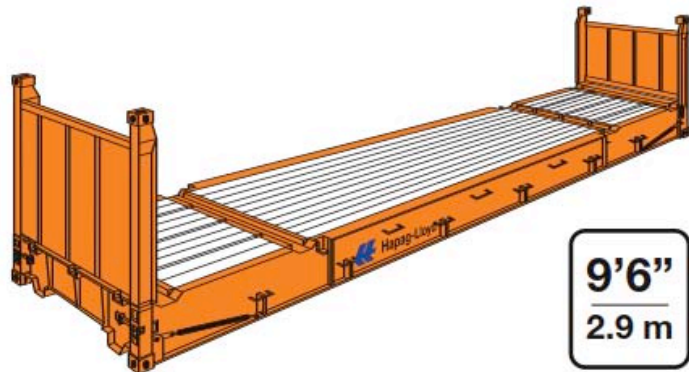

Figure 36. 40 feet flat container, from <https://www.hapag-lloyd.com/en/products/fleet/container.html>.

Flat-Collapsible and/or Convertible into a Platform

20'/40'

ISO Size Type Code: according to Flat Series

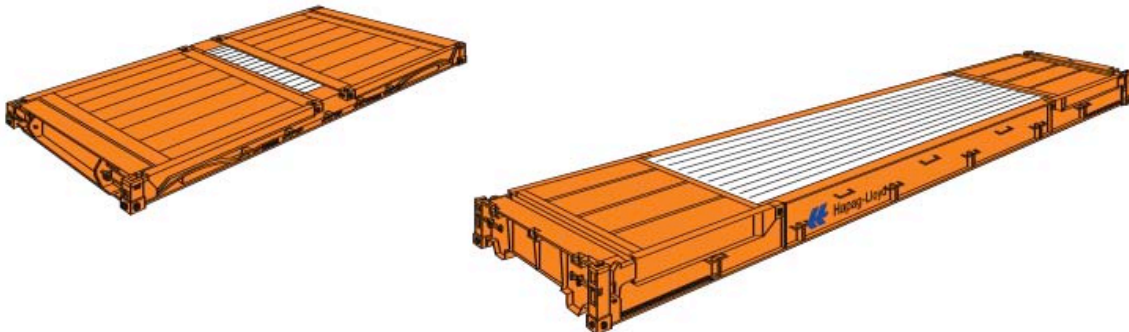

Figure 37. 20/40 feet flat-collapsible container, from <https://www.hapag-lloyd.com/en/products/fleet/container.html>.

- Ventilated version is used for goods that need ventilation.

Ventilated Container

20'

ISO Size Type Code: 22V0



Figure 38. 20 feet high cube container, from <https://www.hapag-lloyd.com/en/products/fleet/container.html>.

- Refrigerated containers (reefer) are used for perishables.

Refrigerated Container (Temperature Controlled Container)

20'

ISO Size Type Code: 22R1, 22R9



Figure 39, 20 feet refrigerated container, from <https://www.hapag-lloyd.com/en/products/fleet/container.html>.

Refrigerated Container (Temperature Controlled Container)

40'

ISO Size Type Code: 45R1 High Cube, 42R9

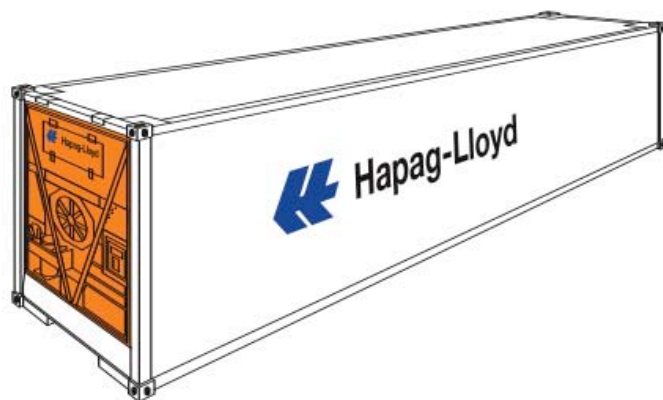

Figure 40. 40 feet refrigerated container, from <https://www.hapag-lloyd.com/en/products/fleet/container.html>.

- Swap body units have the same bottom corners as intermodal containers but are not strong enough to be stacked. They have folding legs under their frame and can be moved between trucks without using a crane.
- A container called a tanktainer, with a tank inside a standard container frame, carries liquids (foodstuffs or chemical products).

Tank Container

20'

ISO Size Type Codes: 20T5 = 8' high, 22T0 = 8'6" high, 22T5, 22T6

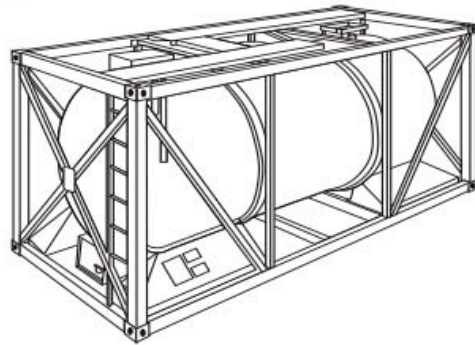

Figure 41. 20 feet tank container, from <https://www.hapag-lloyd.com/en/products/fleet/container.html> .

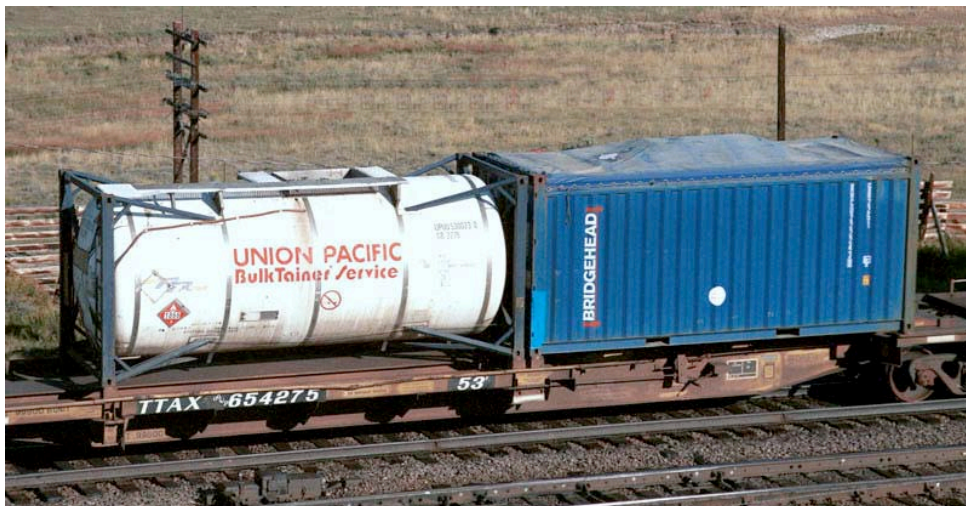

Figure 42. Tanktainer & open-topped container covered by a fabric curtain, from https://en.wikipedia.org/wiki/Flatcar#/media/File:Railroad_car_with_container_loads.jpg .

3.2 Container-Carriers

The North American intermodal industry has been employing two transport technologies, which both imply the vertical transshipment of the intermodal equipment:

- Container on Flatcar (COFC): This is the transportation of both marine (ISO) and domestic containers on a flat car, which is a container wagon in European terminology. American railways emphasize that the COFC movement is made without the container being mounted on a chassis (see Figure 9).



Figure 43. Double-stacked container well cars, from https://en.wikipedia.org/wiki/Well_car#/media/File:DTTX_724681_20050529_IL_Rochelle.jpg

- **Trailer on Flatcar (TOFC):** This is the movement of a semi-trailer or a container mounted on a chassis on a special flat car. This technology is also known as piggyback transport (see Figure 10). Some flatcars are designed with collapsible trailer hitches so they can be used for trailer or container service. Such designs allow trailers to be rolled on from one end, though lifting trailers on and off flatcars by specialized loaders is more common. TOFC terminals typically have large areas for storing trailers pending loading or pickup.



Figure 44. Highway semi-trailers in piggyback service at Albuquerque, New Mexico, from https://en.wikipedia.org/wiki/Intermodal_freight_transport#/media/File:Roadrailleurs.jpg .

If the rail line has been built with sufficient vertical clearance then Double-stack rail transport can be used. Where lines are electrified with overhead electric wiring double stacking is normally not possible. The mandatory requirement to fit under overhead wire for the traction engine electrical power supply sets the height limit for the railcars to allow for trailer transport. This requires a certain low building height which led to a minor size of wheels for the railcars. Hence increased degradation of bogeys by wheel wear-out is a cost disadvantage for the system.

When carried by rail, containers can be loaded on flatcars or in container well cars. In Europe, stricter railway height restrictions (smaller loading gauge and structure gauge) and overhead electrification prevent containers from being stacked two high, and containers are hauled one high either on standard flatcars or other railroad cars. Taller containers are often carried in well cars (not stacked) on older European railway routes where the loading gauge (especially with the reduced gauge for UK lines) is particularly small.

Narrow gauge railways of 610 mm (2 ft) gauge have smaller wagons that do not readily carry ISO containers, nor do the 30-foot (9.14 m) long and 7-foot (2.13 m) wide wagons of the 762 mm (2 ft 6 in) gauge Kalka-Shimla Railway. Wider narrow gauge railways of e.g. 914 mm (3 ft) and 1,000 mm (3 ft 3 3/8 in) gauge can take ISO containers, provided that the loading gauge allows it.

4 BUSINESS MODELS

This chapter will present the business models in Europe and the U.S.

The business models, in Europe, mostly reflect the fairly complex structure of intermodal actors. They are particularly determined through the establishment of a new category of specialized logistic service provider, the intermodal operator. They feature a very straight supplier-customer relationship while, which is not familiar in North America. The European intermodal operator is economically responsible for and organizing the intermodal chain of transport, develops and defines the products and determines how services are produced on rail.

While the business models of the North American intermodal industry differ largely, in most cases even fundamentally, from the situation in Europe. In America, the key players are the major freight railways that have shaped the intermodal business models.

In order to highlight the main differences and similarities between America and Europe, we will first describe the European North American business models and then compare them with North American the ones.

4.1 Intermodal business models in Europe

The differences in the economic and regulatory framework of the European rail freight industry compared to the American situation had a substantial influence on the business models of European intermodal traffic though they haven't completely prejudiced them. The main differences are as follows:

- European Union legislation requires from state railways to separate the management of the infrastructure from commercial activities.
- Freight railways in the U.S. provide for their own, private rail network. Since, in Europe, networks are state-owned public infrastructure network managers are subject to EU and national regulation, which requires them to ensure a non-discriminatory access for every authorised user.
- The situation is similar with regard to intermodal terminals in Europe as most of them are publicly owned.

The liberalization of the rail freight industry in Europe made impossible an “all-inclusive” intermodal business model such as in North America. But even when European railways were integrated companies the business models were much more complex than in North America and essentially centered around a new category of logistic service provider, the intermodal operator. So not only did the regulatory framework impact on the shape of business models in Europe, but it also did on the mentality. From the beginning in the 1960s the intermodal operators had the primary function to bring together two rather antagonistic “worlds”, the world of state railways and the world of shippers and logistic service providers that had cargo to be moved. Intermodal operators were supposed to link the demand for rail services with the production side of rail transport.

This role has been maintained to date. What has changed significantly however, is that intermodal operators have strengthened their responsibilities and involvement in the intermodal chain. Among the various business models, the classic or generalist type of

intermodal operator is estimated to represent a market share of about 60 per cent of total intermodal rail/road traffic in Europe. It is characterized as follows (see also Figure 44):

- This intermodal operator is defining, implementing and operating intermodal services on account of third parties.
- He is used to operate “open” services. Train space can be booked by any customer. Increasingly, this intermodal operator is purchasing block train services from railway undertakings and thus takes on the economic risk of filling train capacity.
- The generalist type of operator traditionally preferred to maintain a “broker” role and keep his assets as low as possible. Therefore, he was purchasing supply services such as transshipment, rail transport, wagons or road trucking.
- In recent years, owing to increased competition in intermodal traffic following the liberalization of this industry and of rail traction, more and more generalist operators have re-considered their approach especially with regard to improving their control on the intermodal supply chain and increased their content of the value chain. Thus, it becomes more important to own or operate key terminals, gain experience in traction services, offer pick-up and delivery trucking.

As concerns the market of continental shipments generalist intermodal operators usually are applying the wholesale model and selling terminal-to-terminal services to forwarding agents, express and parcel carriers and road operators, which themselves deliver the door-to-door services to shippers and also organize the over-the-road pick-up and delivery of equipment. So, the market positioning of European intermodal operators completely match the approach of the U.S. freight railways to their domestic traffic, which is comparable to the European continental services. Obviously, the intermodal service providers on both continents do acknowledge the leadership of the logistic industry in this market and prefer a clear and neutral distribution channel for their services.

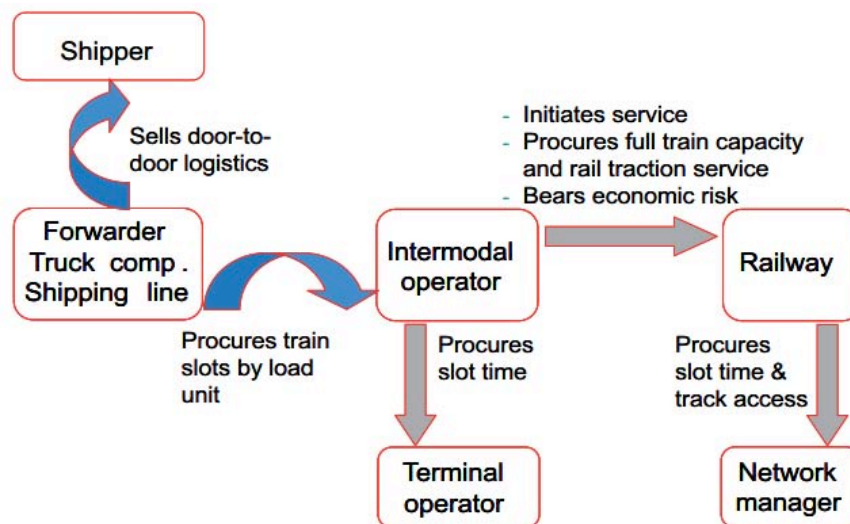

Source: KombiConsult

Figure 45. Business model of European intermodal traffic: generalist type of intermodal operator

As concerns the rail hinterland traffic of marine containers European intermodal operators are faced with a very different situation compared to American railways. The latter can focus on one group of customers, the steamship lines. In Europe, carrier’s haulage - when the shipping line is controlling the hinterland transport of a container - has gained market shares in recent years. Despite this, European forwarding agents traditionally strong in controlling the

transcontinental movement of containers have maintained a firm market presence. According to industry information, the majority of hinterland containers continue to be shipped under merchant haulage as it is called. As a consequence, generalist intermodal operators in Europe are usually required to serve both customer groups in order to make sure their trains are loaded efficiently. As regards the scope of services, though, they are largely in the same position as their American colleagues. They deliver both port-to-door and door-to-door services. For the latter, they are used to contract trucking companies to carry out the road leg of the service.

In addition to the business model of the generalist intermodal operator two other business models have become more common in Europe. One of them is the railway in operator role. Freight railways, which previously carried out traction services on behalf of intermodal operators, are seeking a horizontal extension of their scope of logistics in combined transport. Usually they are providing an “open” system of intermodal services targeting primarily the logistic industry’s customers. In this respect those European railways are drawing nearer to the business model of U.S. railways.

Another intermodal business model may be designated as logistic service provider in operator role. It has been developed by forwarders and shipping lines whose core business is to perform door-to-door or port-to-port logistics. Initially, their intermodal services were rather designed as “closed systems” for conveying shipments arising from within their own logistics. However, the companies quickly adopted the operator role by offering spare transport capacity to other users in order to improve the capacity utilization rate, and, with the extension of the business, specifically plan intermodal services with regard to volumes of third parties. Some of these new operators even push the integration further ahead by providing rail transportation or terminal handling services of their own.

By establishing proprietary intermodal services the logistic service providers extended their existing value chain and accomplished an increased integration of the supply chain. At the same time, they “eliminated” the broker function of the generalist operator at least for those shipments, which are carried on their own services.

4.2 Intermodal business models in North America

The major North American freight railways are the only ones that design, organize, sell, produce and fulfil intermodal services as a kind of one-stop shop. A prerequisite for this business model – though not necessarily its “logic” result – is full integration. The US Railways own and provide themselves for the majority of critical resources, as follows:

- Rail network. Additionally, if they seek to supply services to locations off their network they can often rely on trackage rights – the right to operate on foreign rail lines by own locos and staff – or haulage rights – the opportunity to subcontract traction service to foreign railway.
- Intermodal terminals.
- Locomotives.
- Wagons. Railways own one part of intermodal wagons required, the other part is supplied from the wagon pool of TTX, a cooperative society, collectively owned by major American railways.

Against this background, the American freight railways have developed distinguished business models for the international and the domestic intermodal traffic segments in terms of

market positioning, selection of distribution channels and scope of services, which reflect the specific logistic requirements and customer structures of both markets. What is remarkable, is that all North American freight railways have adopted the same business models except for one case, which will be explained below.

The North American intermodal industry considers the international traffic, the transport of marine containers between ports and inland locations, as a retail business. This means that they sell these services directly and virtually only to steamship lines, which in turn organize the entire transcontinental movement of a container on behalf of a shipper. Depending on customer preference railways provide either a port-to-door or a port-to-terminal service (see Figure 45). If it's a door-to-door transport including drayage, i.e. the over-the-road transport of a container between a terminal and a customer location, railways usually do not carry out this service but contract it to a motor trucking company.

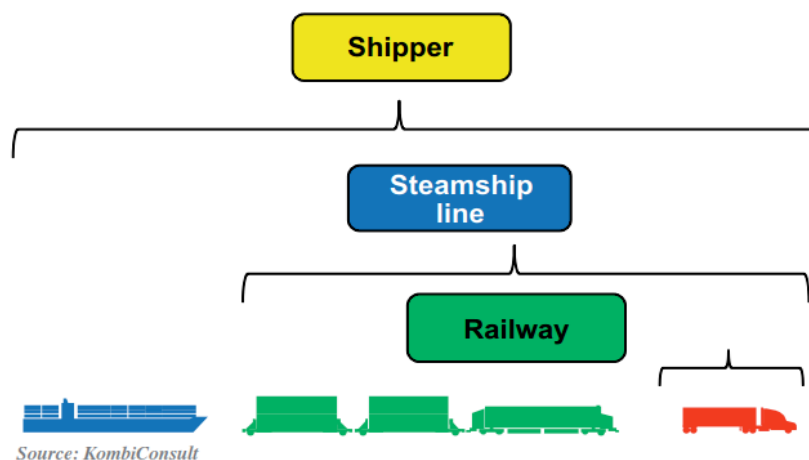

Figure 46. Business model in U.S. international intermodal traffic

The US Railways' approach of domestic intermodal transport is as clear as their approach of international traffic. There is however one exception, and it is not generally so in Canada. Railways in the U.S. are selling domestic intermodal services on a wholesale basis to various groups of logistic services providers who have the contact to the final customer such as the industrial manufacturer or retailer of consumer goods. They therefore organize and carry out the door-to-door service (see also Figure 20 overleaf). Domestic intermodal customers come from the following categories of logistic service providers:

1. Motor carriers are likely to represent the largest group of logistic service providers in America. These are road operators performing full-truckload (FTL) movements with own and – if it's not an owner-operator - contracted trucks and drivers. Over the past 20 years, road-based companies and increasingly big motor carriers have become major customers to the intermodal industry since they have recognized the economic benefits of using rail for long hauls and deploying their trucks for local or regional drayage services. Main customers are J.B. Hunt, Schneider National, Swift, and Werner. Virtually all motor carriers started intermodal traffic by employing lifttable trailers. In recent years, many of them have changed their equipment strategy and are shifting to domestic containers, which – due to double-stack transport – ensure more favourable rail rates. FTL usually are less time-sensitive but very cost-oriented.
2. Less-than-truckload (LTL) carriers in North America are committed to a service, which, in Europe, forwarding agents for groupage cargo do. They collect small-size freight flows, below FTL loads, on a regional level and consolidate individual shipments to full truckloads at their hubs. At the receiving hubs, the truckloads are broken up, shipments

sorted and distributed by delivery trucks. In contrast to Europe where many, especially medium-size forwarders are sharing the groupage market, in the U.S., LTL carriers are a comparatively small group of service providers with a handful of companies dominating about 75 to 80 per cent of the market volume. Notwithstanding that LTL shipments – like in Europe – are extremely demanding as concerns transit time and reliability, American railways were successful to establish intermodal services matching these requirements. As a result, major LTL carriers such as Yellow, Con-way or FedEx National LTL have become regular customers.

3. Parcel carriers have virtually the same service level requirements. UPS, the largest parcel service provider in the world and the top U.S. logistic company, is not only using intermodal services intensely but, according to railway information, is even the biggest customer of U.S. domestic intermodal traffic. Another parcel carrier moving freight on intermodal services is U.S. Postal Services.

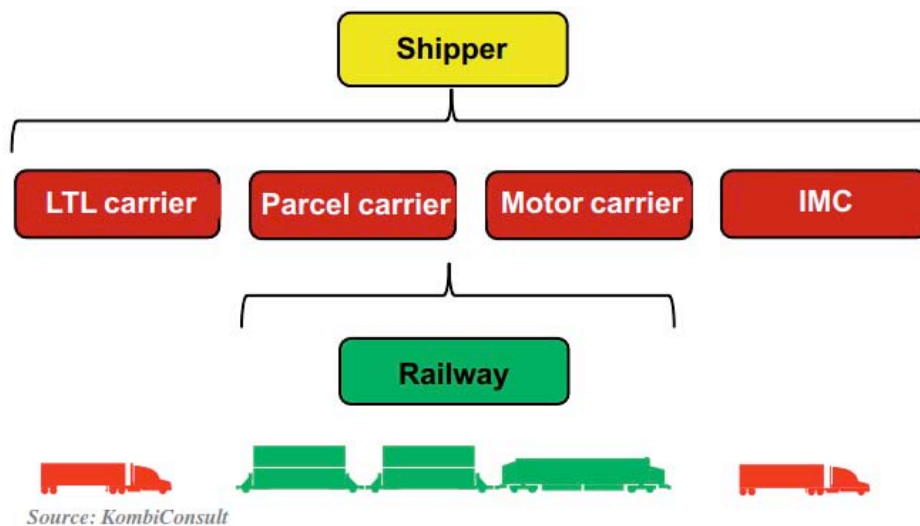

Figure 47. Business model in U.S. domestic intermodal traffic

4. Intermodal marketing companies (IMC) emerged in the 1980s. IMC's or third parties, as they were called, generally, were asset-free logistic companies that were committed to shifting freight from road to rail. They were a kind of "freight broker" that bought fixed capacities of intermodal trains and filled them with loads they collected mostly from smaller shippers. Logistic operations such as trucking were used to be contracted. Meanwhile IMC's have extended this basic business model and equally have freight moving over the road. Too, some IMC's own assets such as containers, trucks, warehouses or even freight wagons. While in the beginning IMC's were a specialty of the North American intermodal industry this business model has been transferred to Europe and is known as 3PL or 4PL on both sides of the Atlantic. Among intermodal customers are 3PL carriers such as APL Logistics, Exel, or the Hub Group, as well as Pacer as one of the few 4PLs, which in the U.S. means a 3PL but doing business with own equipment.

The capabilities of these target customer groups have not only determined the market positioning of U.S. freight railways in domestic traffic – no direct sale to shippers - but also the scope of service. Since all customers - except for many IMC's – employ own intermodal equipment and usually organize the pick-up and delivery of intermodal equipment themselves the U.S. freight railways overwhelmingly provide terminal-to terminal services or ramp-to-ramp services as it is also called in the U.S.

In earlier years, railways were used to supply customers that didn't provide for own, leased or rented intermodal trailers or containers, with rail-controlled equipment. They particularly had a large fleet of liftable trailers, which was deliberately reduced to promote the more cost-efficient container transport (see also chapter 9). For example, Norfolk, Southern and Union Pacific established a joint pool of 53' domestic containers. Compared to the amount of customer-owned equipment – only J.B. Hunt provides for a fleet of some 40,000 53' domestic containers - the extent of rail-controlled equipment, however, is moderate.

North American domestic intermodal traffic knows two major exceptions from the business model described above:

1. As concerns their U.S. activities, Canadian National and Canadian Pacific are delivering domestic services through wholesalers like all Class I freight railways. In Canada, however, they are providing the majority of domestic movements on a direct to retailer basis including the door-to-door transport of cargo. It could not yet be clarified whether this market positioning leads to conflicts of interest and “internal” competition for freight with their wholesale customers.
2. Triple Crown Services, a subsidiary of Norfolk Southern, operates a dedicated network of RoadRailer services east of the Mississippi. Triple Crown is a full-service logistic provider directly to shippers. Based on its fleet of some 6,500 RoadRailer trailers the company is organizing and performing the door-to-door transport of commodities. It has particularly been serving the automotive industry but has now broadened its customer base. Triple Crown is renowned for its superb service quality and has won a couple of industry awards over the years. The RoadRailer technology is a stand-alone system not compatible with “conventional” intermodal equipment and infrastructure. In order to create a market for this technology it is supposed that Triple Crown was obliged to select this retail-based business model.

4.3 Comparison of American and European intermodal business models

The key players who initiate, design and manage intermodal services differ in Europe and in North America. In America, the major freight railways are driving intermodal traffic and have developed distinguished business models for the domestic and the international business, which are taking account of the specific patterns governing the demand side of the American logistic industry.

European intermodal traffic, in contrast, has primarily been shaped by intermodal operators. They are a new category of logistic service provider tailored to the specific economic, regulatory and competitive environment of the European continent. There is no direct equivalent of the intermodal operator in Northern America even though the early IMCs and intermodal operators had some common features particularly as concerns the “broker” role.

What strikes the European expert is that the American intermodal industry seems to opt for rather standardized business models. US Class I freight railways design similar intermodal

products for the same group of customers and establish comparable service promises. One reason for this situation might be a lack of competition since every major freight railway owns its network of lines, This could reduce the necessity for every company to distinguish itself from another. The authors of this report, however, believe that the fairly homogeneous business models much more reflect a mentality of many American enterprises. They wish to keep their business simple and understandable for their customers, or as BNSF has put it

in a presentation on its Intermodal Vision: “Create intermodal rail service for our customers that is easy to understand and use: simple network; simple network offerings.”

The situation in Europe seems to be quite different. Any business model is much more complex and less transparent than in the U.S. In our view this is primarily owing to the fact that, in Europe, virtually every physical or organizational role in the intermodal chain of transport has also been allocated to a separate actor.

Further, even if we can pinpoint the major business models, most intermodal operators tend to differentiate services and if it’s through “cosmetic” supplements. The variety or even diversity in the European intermodal industry is also reflected in the number of intermodal service providers. According to the 2007 UIC Combined Transport study, 105 companies supplied intermodal services in Europe. Their aggregated traffic volume, however, accounted for just about 60 per cent of the number of shipments moved by the six major North American freight railways in the same period. Even if we consider that most domestic intermodal markets in Europe continue to be served primarily by national service providers one could wonder if the polypolistic market structure is really healthy for this industry and fostering its progress.

Table 4. Key actors of intermodal traffic in Europe

	Actor	Description
Demand side	Steamship line	Overseas transport of containers
	Forwarding agent	Organization of door-to-door transport of cargo for third parties independent of mode of transport
	Road operator	Carrying out of freight transport for third parties with trucks
	Shipper	Distributor or procurer of commodities (manufacturer, commerce)
Supply side	Railway (undertaking)	Supplier of rail traction services; carrying out of freight transport by rail
	Infrastructure (network) manager	Owner and operator of rail infrastructure (tracks, signals etc.)
	Terminal operator	Manager of intermodal facility enabling rail/road transshipment
	Wagon operator	Supplier of intermodal railcars for lease or rent
	Intermodal operator	Supplier of intermodal services

Source: KombiConsult

5 STATISTICS

This chapter will present the intermodal volume in Europe and the U.S.

5.1 Comparison of intermodal volume in North America and Europe 2007

In 2007, the intermodal industry in Europe achieved an all-time record when volumes rose to 17.1 million TEU.⁵ Despite that, total North American intermodal traffic was almost 70 per cent and U.S. traffic about 45 per cent higher than in Europe. While, in America, the two intermodal market segments, international and domestic/continental traffic, accounted for almost the same amount of TEU, in Europe, hinterland rail transport of marine containers came off better with a share of 57 percent (see Table 4). This is particularly owing to the different pattern of intermodal equipment employed on both sides of the Atlantic. 20' and 30' tank and bulk containers mainly carrying chemical products have a rather high percentage of European continental traffic. It is obvious that the "TEU weight" of those units is substantially smaller than the 48' and 53' domestic containers and trailers, which clearly dominate the American domestic market.

Table 5. Intermodal traffic in North America, USA and Europe by segments: 2007

Market segment	Intermodal traffic volume (TEU)		
	North America	USA	Europe
Domestic / Continental	14,400,000	12,900,000	7,352,855
International / Container hinterland	14,300,000	11,800,000	9,759,965
Total	28,700,000	24,700,000	17,112,820

Source: IANA, AAR, UIC, KombiConsult calculations

The U.S. intermodal industry also has a lead over Europe as concerns the tonnage shipped on intermodal services though the edge is distinctively smaller. According to our calculations the US Class I freight railways moved a gross weight of 205 million metric tons, in 2007. This gives an average of 17 tons per intermodal loading and 8.3 tons per TEU. In the same year, European intermodal traffic amounted to 172.2 million tones thus 19% less than in the U.S.

Overall average gross weight, however, was more than 20% higher and even reached 10 tons per TEU.

First of all, this finding suggests the structure of commodities varies between both intermodal industries. In fact, U.S. railways representatives reported that both on domestic and international services the share of light-weight products is comparatively high. International traffic is dominated by full import containers from China and other eastern Asian countries carrying mostly voluminous consumer goods, and empties returning to ports. But also, domestic intermodal services are often geared to customers shipping rather light-weight consumer goods, industrial products, parcels, and Less-than-Truckload (LTL) shipments. In contrast to that, the European intermodal industry can sell services especially for continental cargo on the argument that, on many corridors, it can enable increased payloads compared to road transport.

In Europe, in contrast to North America, comprehensive statistical data on intermodal traffic hadn't been recorded prior to the pioneering survey of the International Union of Railways (UIC) in 2006. Until then, although only representing approximately 35 per cent of the total intermodal traffic volume, the only reliable source of domestic and international intermodal data was provided by the UIRR (association of intermodal operators) see Figure 47.

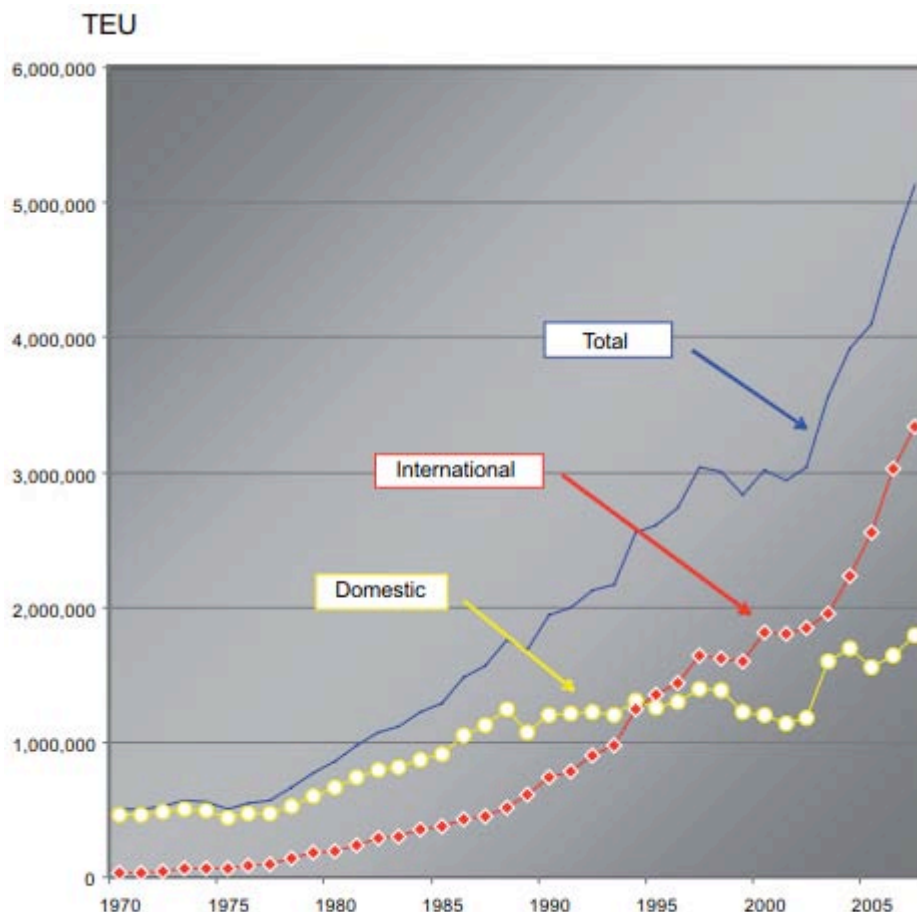

Source: UIRR, KombiConsult graph

Figure 48. Intermodal traffic of UIRR member companies: 1970-2007

6 MANAGEMENT & FINANCE

This chapter will present wagon management and financing methods in Europe and the U.S.

6.1 Intermodal Wagon Management

The objective of wagon management is to provide the appropriate number, type and quality of wagons at the right place, at the right time and at a reasonable cost. In order to meet these requirements, wagon management covers the entire life cycle of a wagon, from market research, procurement, financing, service assignment and operations to maintenance and deployment of used wagons. In this respect, the survey on intermodal transport in the U.S. is not only highly instructive since the industry there has chosen a completely different model for the provision of specialist intermodal wagons than in Europe, but is also startling as the U.S. is always considered as the home of competition.

6.2 Intermodal wagon management in the U.S.

In the U.S., freight railways only own a small proportion of all intermodal wagons employed. The bulk of these wagons are actually provided by TTX.

What might be viewed spectacular from a European perspective is that TTX is a cooperative company whose shares are owned by ten of North America's leading railways which are also its primary customers (see Figure 48). Today, TTX manages a pool of over 210,000 rail wagons employed for intermodal and automotive services as well as carrying lumber, machinery, building materials, steel, and other commodity groups where flat, covered and open wagons are required. Both the business model and the pooling agreements are under the jurisdiction of the DoT Surface Transportation Board which has granted TTX a limited anti-trust immunity, i.e. exempted the company from competition law.



Source: TTX, KombiConsult

Figure 49. TTX Company's ownership

TTX was established in 1955 by 41 railways with the aim of sharing assets in particular Trailer-Train equipment, for which railways wanted to share the economic risk. Today the main objective of TTX is to supply the U.S. railways with a fleet of reliable, high quality wagons matching the specific demand of their customers at competitive rates. TTX is also responsible for keeping the fleet at a reasonable size, balancing new equipment acquisitions with innovative modifications and upgrading the existing fleet. The major general benefits, which TTX renders to its customers, are as follows:

- Low-cost equipment resulting in inexpensive hire rates
- A reduction in idle days thanks to an efficient North America-wide pool of wagons
- Capital conservation: railways must not bear the capital cost for new equipment
- The owners' equipment risk is virtually eliminated thanks to the possibility for wagons to be returned within 5 days and for wagons to be modified for alternative uses
- TTX has three maintenance divisions performing various types of repair and modification work, and 31 Field Maintenance Operations carrying out inspections and less extensive repairs on site
- Market analysis and planning
- Engineering research and development

The Intermodal Equipment Distribution Services handle day-to-day management for all intermodal wagons. On an average day, 92 to 94 % of the fleet is in service. TTX's distribution system enables wagons to be directed from railways with excess capacity to those railways that are short of wagons. This ensures that customers have sufficient equipment when they need it. In addition, wagons are directed to and from repair facilities and new wagons are brought from manufacturers to the railways. TTX, however, does not interfere with the freight railways' operational business and e.g. assigns wagons to services or determines wagon sequences.

Over the past ten years, TTX has invested \$3.9bn (€3.0bn) in new wagon purchases, with 61 % dedicated to intermodal wagons. TTX currently operates a fleet of approximately 44,000 intermodal wagons. From a European standpoint, this straight figure would underestimate the fleet size as the majority of wagons are articulated vehicles comprising two, three, five, six, eight or even ten units or platforms for carrying intermodal equipment. Therefore, the total loading capacity of TTX wagons in terms of intermodal units is estimated to be more than six times higher than represented by the number of 44,000 wagons. The current TTX intermodal fleet breaks down as follows:

- Less than 5% of all wagons are single-unit vehicles.
- About 12,500 wagons are designed to carry trailers though some can also accommodate containers. They provide a loading capacity for almost 50,000 large road trailers. The most common design is the spine wagon, which in a similar design is also used in UK intermodal traffic. The spine wagon features a fairly "lean" design just composed of a central longitudinal beam, a platform for accommodating the trailer's axles, and a coupling device to absorb and secure the king pin.
- The majority of trailer-carrying wagons meanwhile are designed for 53' or 48' long trailers.
- Approximately 31,000 wagons are double-stack container wagons providing for more than 160,000 platforms. Since not every platform corresponds to a 40'+ container slot, the total loading capacity cannot readily be calculated. However, we estimate that

double-stack wagons account for a loading capacity of almost 300,000 40' or larger containers.

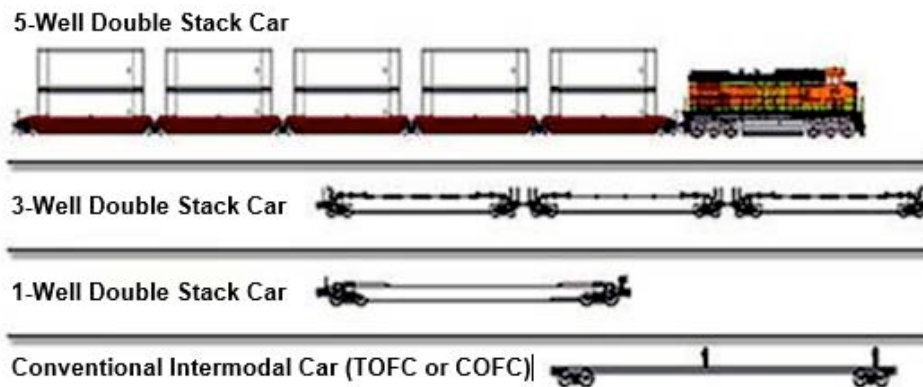

Figure 50. Most common intermodal wagons in North America, from <https://www.bsnf.com>.

6.3 Comparison of intermodal wagon management in the U.S. and Europe

In Europe, the business models for the provision and management of intermodal wagons vary substantially from the American cooperative wagon pool represented by TTX. Four basic models, disregarding how wagon purchases have been financed, are applied here:

- Incumbent railway undertakings (RUs) own and manage a large proportion of the intermodal wagon fleet. If requested by intermodal operators to quote a rate for a block-train service, RUs usually offer to supply their “railway” wagons for a separate rate as well.
- Some intermodal operators have procured a significant fleet of “private” intermodal wagons, which they manage on their own and usually only deploy on proprietary services.
- Other intermodal operators possessing wagons have handed over the management of their vehicles to a RU, which holds shares in the company concerned.
- Leasing/renting companies most likely have contributed most to increasing the fleet of intermodal wagons in Europe over the past 20 years. The market leader here certainly is AAE. These companies have succeeded in providing wagons to virtually every provider of intermodal or rail haulage services.

In the U.S., the intermodal wagon – or even more general, the rail wagon – is viewed rather as a “commodity” and not as a piece of competition. In this respect, there are great similarities with the motor-carrier and entire logistics industry in the U.S. For U.S. railways, it is obviously more important that TTX provides state-of-the-art and well-maintained wagons at competitive hiring rates, ensures optimum utilization and assumes capital risks on “broader shoulders” than trying to compete on wagons. It bears pointing out, however, that the level of competition between Class I railways in intermodal traffic is not that intense considering that every railway owns a large network connecting major economic centers in the U.S.

By contrast, in Europe, a cooperative pooling potential corresponding to the TTX business model is very unlikely to be realized, as things now stand. Wagons are not regarded as

“commodities” but as an instrument to achieve a competitive edge over others. This also applies to IT systems, intermodal equipment and other resources. This attitude is understandable against the background of the liberalization of the European rail freight industry. Market economy and competition are highly appreciated and demanded from authorities – competition at every level is the order of the day – in an attempt to achieve a more efficient railway system.

For the time being, it has yet to be determined whether the European approach to managing necessary and valuable inputs for the production of intermodal services really brings about more efficient results than the U.S. solution. In the current, still transitory situation from a state-owned, integrated railway system to a new market balance, it would certainly be difficult to delve into this issue. Anyone daring to take a step in this direction would be suspected of trying to stifle competition. But authorities should ask themselves whether control over critical resources such as wagons does not in itself constrain the forces of competition.

6.4 Financing of intermodal terminal investments

Up to now, the U.S. railways have financed their intermodal terminal investments completely from their own resources.

They are all the more “irritated” to observe projects initiated by cities or regional development agencies securing public funds or a 25 % tax discount for establishing intermodal facilities.

There are also some projects which may be categorised as public-private partnerships. Public administrations or related companies build and own a terminal presumably to promote regional development. They strike a deal with a railway that commits to serving the facility with intermodal trains. NS has given the example of a West Virginia terminal in this respect.

In Europe, intermodal terminals are wholly privately financed very seldom. Usually the investor can obtain public funds, though the extent and also the scope of funded components varies considerably. Since the funding schemes are intended for implementation on a national scale, the system is not very transparent. Given that, we can distinguish the following schemes:

1. Financing of investments in national state railways terminals:
 - States cover full cost or cost of infrastructure, while operator pays for superstructure.
 - Terminal operations had often been entrusted to national intermodal operators or railways.
 - Owing to EU legislation requiring non-discriminatory access, operations are now integrated into infrastructure manager companies or in joint ventures with other companies.
2. Financing of investments in private terminals:
 - Very few such schemes.
 - Most of them not “really” private: e.g. Investment by local port or railroad authority (shares held and financed by city administrations).
 - Regional subsidies.

3. Investment by private companies in public terminals fostered by a range of subsidies across Europe:

- EU basically allows up to 50 % funding of infrastructure and 30 % of handling equipment
- France & Italy: regional authorities give approximately 30 % grants towards investment in handling equipment, IT systems, etc.
- Netherlands: up to 50 % state and region grants
- Switzerland (non-EU): up to 80 % grant or zero-interest loan on total investment
- Germany: up to 85 % state grant on total investment

Table 6 Financing of Intermodal Stations

Financing of Investments in National State Railways Terminals				
	States	Operator	National Intermodal Operators	Railways
Cost of infrastructor	x			
Superstructure		x		
Terminal Operations			x	x
Financing of Investments in Private Terminals				
Very few such themes				
Most of them not "really" private: e.g. Investment by local port or railroad authority (shares held and financed by city administrations)				
Regional subsidies				
Investment by Private Companies in Public Terminals Fostered by a Range of Subsidies Across Europe				
	Funding of Infrastructure	Handling Equipment	Total Investment	
EU basically allows up to	50%	30%		
France & Italy: regional authorities		30%		
Netherlands			50%	
Germany			85%	
Switzerland (non-EU)			80%	

7 INTERMODAL GROWTH

This chapter will present the key drivers of intermodal growth in Europe and the U.S.

7.1 Key drivers of intermodal growth in Europe

Key drivers of intermodal growth in Europe

1. Growth of foreign trade and cross-border freight volumes between Member States of the European Union (EU):
 - Elimination of trade barriers (European Single Market)
 - Deregulation of freight transport sector
 - EU enlargement
2. Growth of global trade and maritime container traffic
3. National port strategies: promotion of rail hinterland transport of seaborne containers
4. Beneficial regulatory framework and/or dedicated subsidies to promote intermodal transport in some European countries (environmental policy; modal shift policy)
5. New business models of intermodal operators (IO):
 - Block-train services: IO define service parameters; train capacity risks shifted from railways to IO
 - Stronger involvement in intermodal value chain (terminals, wagons, rail haulage, road pick-up and delivery)
 - Downstream” and “upstream” extension of logistics service providers
6. Restructuring of intermodal service supply:
 - Cut-down of extensive networks serving every station, especially in domestic traffic
 - Strengthening of competitive, viable trade routes
7. Development of international intermodal networks following “Europeanisation” of freight and logistics
8. Innovative and improved production systems such as shuttle trains, gateway or hub operational schemes
9. Enhanced timetables matching customer requests
10. Cost and service competition at railway and operator level

11. Only rail – and barges for Antwerp & Rotterdam – were able to move the increasing volumes of containers
12. Leading manufacturers e.g. from the chemicals, automotive or paper industry requesting intermodal solutions (cost + safety, supply chain, environment)
13. Soaring price level in road transport since 2006:
 - Diesel price increase
 - Reduction of lorry-driver workforce
 - More stringent EU regulation of lorry drivers' driving and resting hours
 - Decreasing price pressure from Eastern European road-haulage companies

7.2 Key drivers of intermodal growth in U.S.

1. Deregulation of rail freight traffic:
 - Productivity gains;
 - Mergers: economies of scale; reduction of interfaces
2. Clear, easy to understand and rather standardised business models and distribution channels
3. Intermodal service innovations
 - Dedicated intermodal services
 - Service levels
 - Guaranteed services
 - Partnerships with logistics service providers: parcels & motor carriers, steamship lines
4. Outstanding improvement of performance of service; goal: 92% rate of punctuality.
5. Technological innovations
 - Double-stack wagons
 - Shuttle trains
 - IT-based central booking/reservation systems
 - RFID and OCR identification technologies at terminal
 - Standardised intermodal equipment
6. Heavy investments in rail and intermodal traffic:
 - Enlargement of network from single to double or triple track line
 - Raising of clearance (double-stack)
 - Advanced signalling systems (capacity increase)
 - Terminals

- Intermodal wagons
 - Locomotives
7. Strong U.S. domestic economy
 8. Growth of maritime container traffic particularly since 2001: elimination of trade barriers for Chinese products
 9. Soaring price level in road transport since about 2005:
 - Diesel price increase
 - Reduction of lorry-driver workforce

Table 7 Key Drivers of Intermodal Growth

KEY DRIVERS OF INTERMODAL GROWTH	
EUROPE	US
1. Growth of foreign trade and cross-border freight volumes between Member States of the European Union:	1. Deregulation of rail freight traffic:
Elimination of trade barriers (European Single Market)	Productivity gains;
Deregulation of freight transport sector	Mergers: economies of scale; reduction of interfaces
EU enlargement	2. Clear, easy to understand and rather standardised business models and distribution channels
2. Growth of global trade and maritime container traffic	3. Intermodal service innovations
3. National port strategies: promotion of rail hinterland transport of seaborne containers	Dedicated intermodal services
4. Beneficial regulatory framework and/or dedicated subsidies to promote intermodal transport in some European countries (environmental policy; modal shift policy)	Service levels
5. New business models of Intermodal Operators (IO):	Guaranteed services
Block-train services: IO define service parameters; train capacity risks shifted from railways to IO	Partnerships with logistics service providers: parcels & motor carriers, steamship lines
Stronger involvement in intermodal value chain (terminals, wagons, rail haulage, road pick-up and delivery)	4. Growth of maritime container traffic particularly since 2001: elimination of trade barriers for Chinese products
“Downstream” and “upstream” extension of logistics service providers	5. Technological innovations
6. Restructuring of intermodal service supply:	Double-stack wagons
Cut-down of extensive networks serving every station, especially in domestic traffic. Strengthening of competitive, viable trade routes	Shuttle trains
7. Development of international intermodal networks following “Europeanisation” of freight and logistics	IT-based central booking/reservation systems
8. Innovative and improved production systems such as shuttle trains, gateway or hub operational schemes	RFID and OCR identification technologies at terminal
9. Enhanced timetables matching customer requests	Standardised intermodal equipment
10. Cost and service competition at railway and operator level	6. Heavy investments in rail and intermodal traffic:
11. Only rail – and barges for Antwerp & Rotterdam – were able to move the increasing volumes of containers	Enlargement of network from single to double or triple track line
12. Leading manufacturers e.g. from the chemicals, automotive or paper industry requesting intermodal solutions (cost + safety, supply chain, environment)	Raising of clearance (double-stack)
13. Soaring price level in road transport since 2006:	Advanced signalling systems (capacity increase)
Diesel price increase	Terminals
Reduction of lorry-driver workforce	Intermodal wagons
More stringent EU regulation of lorry drivers’ driving and resting hours	Locomotives
Decreasing price pressure from Eastern European road-haulage companies	7. Strong U.S. domestic economy
	8. Outstanding improvement of performance of service; goal: 92% rate of punctuality.
	9. Soaring price level in road transport since about 2005:
	Diesel price increase
	Reduction of lorry-driver workforce

8 DESIGN PROCESS

This chapter will present the design concept for an inland port.

8.1 Geo-Positions

Regional issues, namely how dry ports interact with their regional markets, remain fundamental as they define their modal characteristics, their regulatory framework and their commercial opportunities. Depending on the geographical setting and the structure, governance and ownership of inland transport systems, dry ports have different levels of development and integration with port terminals.

Western Europe

It is in Western Europe that the setting of inland terminals is the most advanced with a close integration of port terminals with rail shuttles and barge services. European integration processes have permitted the setting of more natural (commercially based) hinterlands that did not exist before. Since a good share of the European market is inland, a growth in international trade required the setting of intermediary locations inland to help accommodate larger flows between ports and their hinterland. Local hinterland logistics are taking the form of emerging logistics poles consisting of a set of gateway ports and logistics zones in the immediate hinterland. A large concentration of dry ports can be found around the Rhine/Scheldt delta, which is Europe's most important gateway region with a total container throughput of 23.2 million TEU in 2011, and where the function of satellite terminals is prominent (Figure 50). Almost every European port has an inland terminal strategy as a way to secure hinterland traffic.

A major concern in many European ports is the strong reliance of more local container volumes on trucks. While road haulage has always played a major role in shaping competition among load centers of the same multi-port gateway region for the immediate hinterland, intermodal transport is slowly but surely acquiring a strategic role as well. Regional trunk lines enhance the location of logistics sites in seaports and dry ports and along the axes between seaports and dry ports. Seaports are the central nodes driving the dynamics in such a large logistics pole. The rise of dry ports and associated logistics corridors enhanced port regionalization processes (Notteboom and Rodrigue, 2005). Logistics sites in the immediate hinterland typically greatly value the flexibility a multi-port gateway region offers in terms of available routing options for import and export cargo (Notteboom, 2010). In a logistics world confronted with mounting reliability and capacity issues, routing flexibility is a keystone for the logistics attractiveness of a region. For example, the logistics attractiveness of large parts of Belgium and the Netherlands for the location of European distribution centers (EDCs) is partly due to the existence of and high connectivity in several efficient gateways in the Rhine-Scheldt Delta.

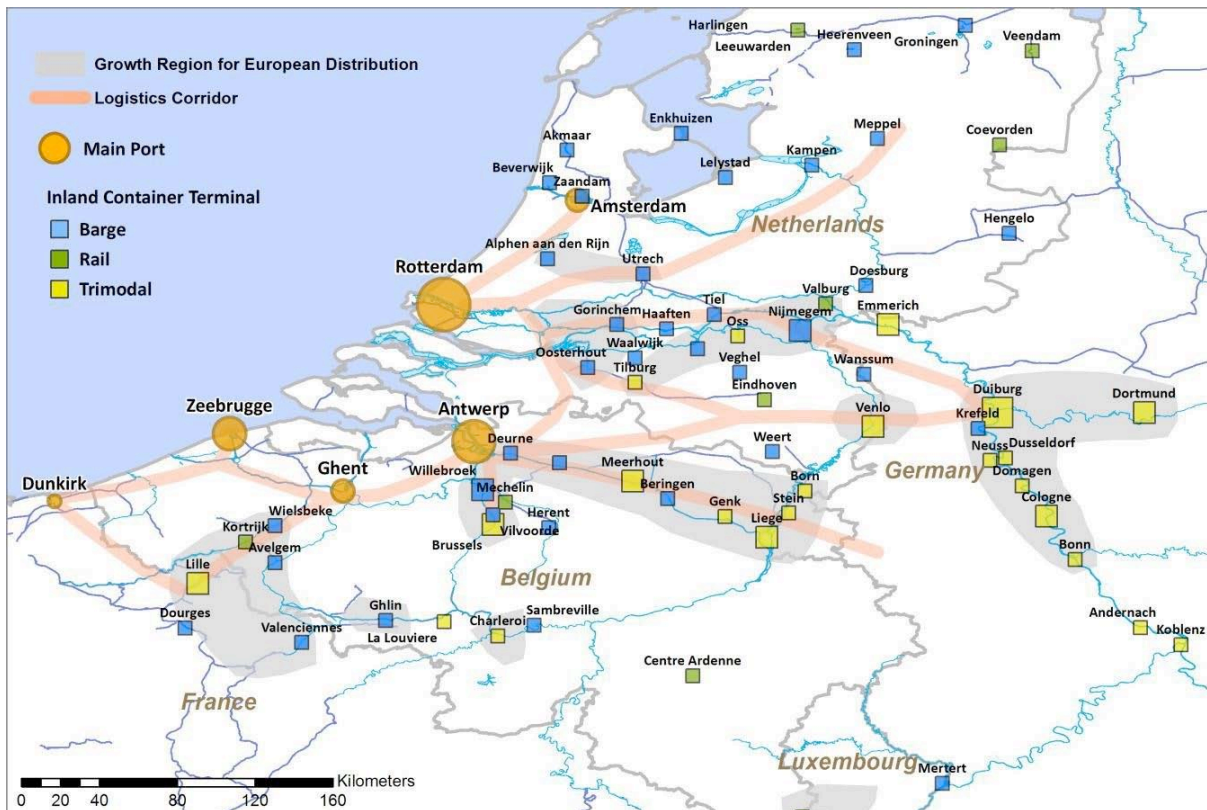

Figure 51. Logistics polarisation in the Rhine-Scheldt Delta: logistics zones, trimodal dry ports, rail-based dry ports and barge-based dry ports, Notteboom (2000)

Rail-based dry ports are found throughout Europe, often linked to the development of logistics zones. The rail liberalization process in Europe is supporting the development of real pan-European rail services on a one-stop shop basis. All over Europe, new entrants are emerging while some large former national railway companies have joined forces. Rail terminals in Europe are mostly built and operated by large railway ventures. The largest rail facilities have bundles of up to 10 rail tracks with lengths of maximum 800m per track. Rail hubs are typically equipped to allow simultaneous batch exchanges (direct transshipment) through the use of rail-mounted gantry cranes that stretch over the rail bundles.

In northwest Europe, rail networks and rail-based dry ports are being challenged by barge transport and bimodal barge/truck terminals which are taking up a very prominent role in dealing with gateway traffic, particularly in the Benelux, northern France and parts of Western Germany. Barge container transport has its origins in transport between Antwerp, Rotterdam and the Rhine basin, and in the last decade it has also developed greatly along the north-south axis between the Benelux and northern France (Notteboom and Konings, 2004). Antwerp and Rotterdam together handled nearly 5 million TEU of inland barge traffic in 2010 or about 95% of total European container transport by barge. Promising barging developments are also found on the Seine between Le Havre and the Paris region, in the Rhône/Seine basin between Marseille, Lyon and Dijon, on the Elbe and the Weser in Northern Germany and on the Danube River out of the port of Constanta. Fluviomar recently started barge services on the Po River connecting the Port of Venice with Mantua and Cremona near Milan.

The increased focus on the hinterland gave impetus to specific coordination mechanisms among stakeholders (Van Der Horst and De Langen, 2008) and hinterland access regimes (De Langen and Chouly, 2004) in ports around Europe. Port authorities such as Rotterdam,

Barcelona, Le Havre, Marseille, Antwerp and Lisbon all are actively enhancing processes of port regionalization (see Notteboom, 2009 for a more detailed analysis). Market players have developed specific concepts to reflect the growing function of inland terminals. For example, some terminal operators in Europe are increasing their influence throughout supply chains by incorporating inland terminals as ‘extended gates’ to seaport terminals (Rodrigue and Notteboom, 2009). Container terminal operator ECT in Rotterdam (part of Hutchison Port Holdings) follows an active strategy of acquiring key inland terminals acting as extended gates to its deep-sea terminals (Veenstra et al., 2012). Through ‘European Gateway Services’, ECT offers shipping lines, forwarders, transport companies and shippers a variety of services to facilitate the optimal flow of containers between the deep-sea terminals in Rotterdam and the direct European hinterland. ECT bundles cargo, which allows for highly frequent inland barge and rail connections to various logistics hotspots in the European hinterland. Container carrier Maersk Line wants to push containers into the hinterland supported by its terminal operating sister APM Terminals and its rail branch European Rail Shuttle (ERS). Terminal operator DP World uses the concept of ‘terminal operator haulage’ to streamline intermodal operations on the Seine and Rhône axes, while the large terminals of Antwerp Gateway (open since 2005) and London Gateway (open in 2012) are both linked to inland centers.

The advantages of the above solutions are substantial: customers can have their containers available in close proximity to their customer base, while the deep-sea terminal operator faces less pressure on the deep-sea terminals due to shorter dwell times and can guarantee a better planning and utilization of the rail and barge shuttles. A close coordination with shipping lines, forwarders and shippers is needed to maximize the possibilities for the development of integrated bundling concepts to the hinterland. We argue that ‘extended gate’ and ‘terminal operator haulage’ strategies will increasingly evolve from point-to-point services (i.e. from a seaport to an inland port and vice versa) to network services which rely on routing flexibility offered via multiple inter-linked corridors.

North America

There have been large inland terminals in North America since the development of the continental railway system in the late 19th century. Their setting was a natural process where inland terminals corresponded to large inland market areas, commonly around metropolitan areas commanding a regional manufacturing base and distribution system. Although exports were significant, particularly for agricultural goods, this system of inland terminals was mostly for domestic freight distribution, connecting manufacturing and resource regions. This has led to a noted hierarchy of distribution hubs within the North American economy (Figure 51). With globalization and intermodalism two main categories of inland terminals have emerged in North America. The first is related to ocean trade where inland terminals are an extension of a maritime terminal located in one of the three major ranges (Atlantic, Gulf and Pacific) either as satellite terminals and more commonly as inland load centers (e.g. Chicago). The second category concerns inland terminals mainly connected to NAFTA trade that can act as custom pre-clearance centers. Kansas City can be considered the most advanced inland port initiative in North America as it combines intermodal rail facilities from four different rail operators, foreign trade zones and logistics parks at various locations through the metropolitan area. Like Chicago, the city can essentially be perceived as a terminal.

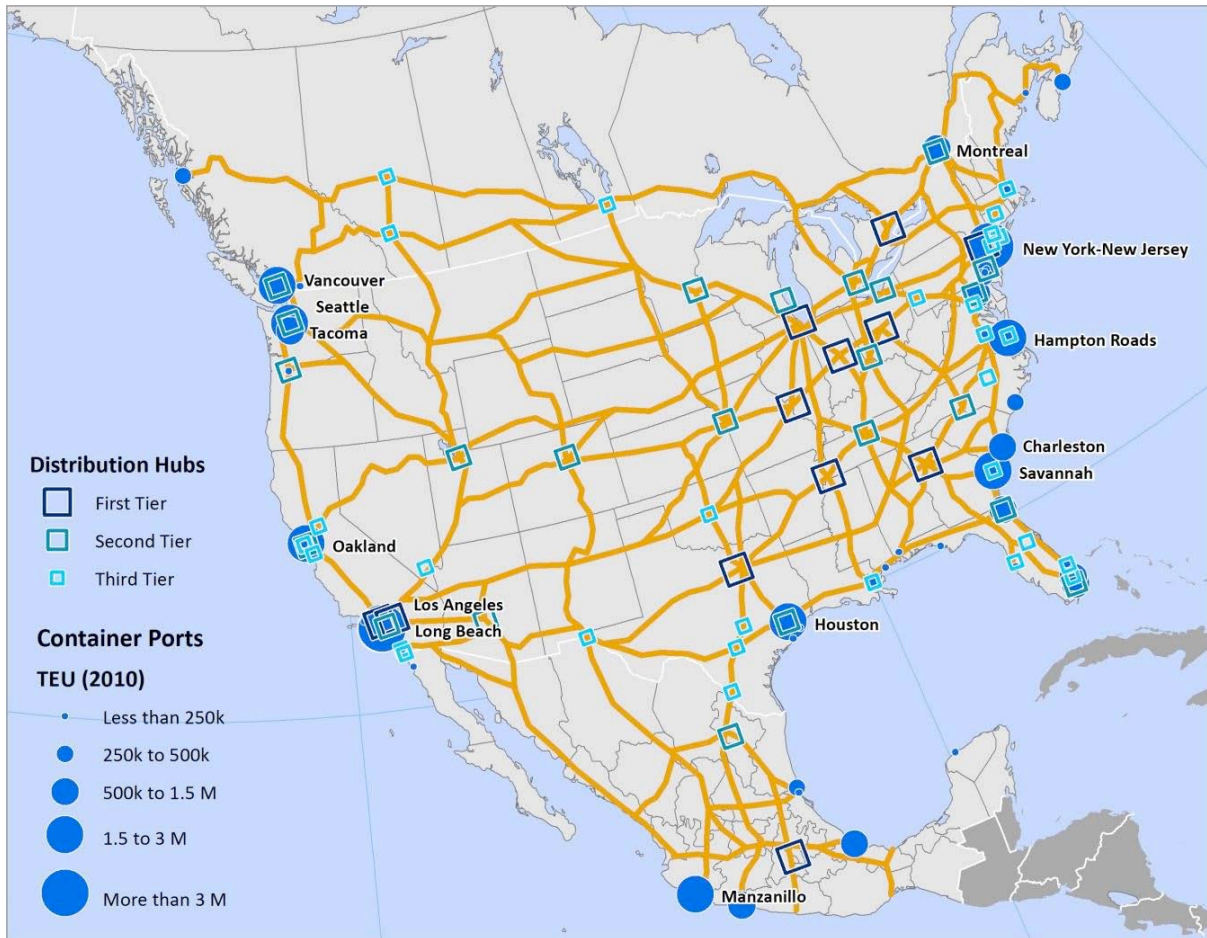

Figure 52. Main Container Ports, Trade Corridors and Distribution Hubs in North America, Cushman & Wakefield (2009).

a modal shift away from road and freight diversion away from congested areas. These two key paradigms have been expanded with a more comprehensive approach leaning on the principle of co-location. As dry port projects become increasingly capital intensive and prone to risk because of their size, required equipment and infrastructure, the need for a higher value proposition is now set on the principle of co-location, many of which are public private partnerships. Several recent logistic zones projects in North America are capitalizing on the planning and setting of a new intermodal rail terminal done concomitantly with a logistics zone project. This co-location partnership fundamentally acts as a filter for the commercial potential of the project as both actors must make the decision to go ahead with their respective capital investment in terminal facilities and commercial real estate. The most common actors in a typical co-located dry port project involve a railway operator and a commercial real estate developer, or a local public development office.

The success of the co-location model in North America is linked to the market opportunities of the intermodal terminal through a set of value propositions:

- **Real estate:** Logistic zone projects tend to occupy a large amount of space to accommodate existing and anticipated freight distribution activities. Most co-located projects occupy at least 250 acres and several projects are well above 1,000 acres. Larger projects tend to have lower land acquisition costs. Also, since co-located projects involve at least two large players, a commercial real estate developer and a railway company, they are able to tap into capital pools with better conditions than a smaller actor (e.g. interest rates). For instance, CenterPoint Properties is owned by the

pension fund CalPERS (California public employees' retirement fund), enabling access to long term capital pools. Another important aspect is that a co-located logistic project enables the joint planning of facilities.

- **Specialization:** A co-location project enables both actors involved to focus on their core competencies, creating multiplying factors. For instance, the rail company can focus on terminal development and operations while the real estate promoter can develop and manage the freight distribution facilities.
- **Interdependency:** both the terminal operator and freight distribution activities at the logistic zone are their respective customers, implying that both partners have vested interests in the efficiency of their operations. The possibility of joint marketing where the logistic zone is promoted as a single intermodal package is also common since the terminal is sold as a value proposition to potential customers.
- **Drayage:** a co-location project offers notable operational advantages for drayage, not just because of close proximity, but because trucks can have a priority access through the terminal's gates (e.g. pre-registration, advance notification, RFID). Drivers are able to perform more deliveries per day and the reliability of these deliveries improves.
- **Asset utilization:** Intermodal transportation assets are capital intensive and there are pressures to increase their utilization level to achieve better returns on investments. Containers and chassis tend to be the assets that are the most prone to such strategies, namely through the setting of chassis pools and empty container depots.
- **Information technologies:** A co-location project offers the possibility to jointly plan information systems for terminal operations and the related supply chains, creating a community system where users can have access to real time information about the status of their shipments. Both terminal operations and their related supply chains benefit.

While co-location dry port projects have been particularly prevalent in North America, one drawback is that co-located logistics activities are dependent on the performance of the rail terminal as well as the level of service offered by the rail operator. If for any reason the rail operator has other priorities within its network, then the efficiency of the co-located logistic zone is compromised.

Table 8 Location of Intermodal Stations

Location Table		
	US	EU
Large inland market areas	x	
Next to ports	x	x
Next to rivers		x
Lowland areas	x	x
Areas with railway infrastructure	x	x
Industrial Areas	x	x
Rail Corridors	x	x

8.2 The cost calculation module

The question of costs in combined transport has always been a “grey” area. There is no universally accepted cost methodology in the railway sector and very little information is available in relation to the breakdown of operating costs. In many cases the rail prices include large over-heads, internal cross-subsidies or are determined according to the highest price that the market can bear (Cantos et al., 1999). Furthermore, no cost data exists for terminals operating on the basis of pilot technologies.

For this reason, a “custom-made” cost calculation scheme has been particularly developed with the aim of comparing the cost-effectiveness of different alternatives. This cost scheme incorporates the following elements:

1. Infrastructure (land acquisition, track formation, rail tracks, switches and signals, crane track, road lanes, gates, buildings, lighting, fencing, etc.) as well as handling and other terminal equipment. The annual cost for these elements was based in an amortisation periods of 30 years for the land and the civil engineering works and 20 years for the various terminal installations and equipment. The interest rate was assumed to be 7% for the whole amortisation period, an assumption based on experts’ opinion (EC/DG Transport, 1999a).
2. Maintenance and power.
3. Personnel for the pure terminal operations. The personnel requirements for each system are calculated according to the terminal volume. It was assumed that these personnel also adjusts/ locks the wagon pins (which is related to “handling”), but does not carry out the “inspection” work because this work is related to “train operation” and the corresponding cost is calculated separately.

4. Train access procedures (from main line to terminal sidings) as well as rolling stock and car-go “inspection” (brake tests, cargo tests, etc.). The costs for these procedures are determined according to access and handling procedures associated with the simulated technological solution.
5. Cost of truck service time in the terminal. It is calculated taking into account the mean truck dwell time in the terminal (average of the simulation replications) multiplied by 37.5 Euros/h. This rate is based on the outcome of a relevant study performed by Eidgenossische Technische Hochschule Zurich, which examines various truck operating schemes (EC/DG Transport, 1999b). Of course, any other rate can be used.

8.3 Dry Ports in Europe

Some examples of dry ports are presented below:

- Prague-Uhrineves (Czechia)



Figure 53. Prague-Uhrineves (CZ) dry port

Table 9. Prague-Uhrineves (CZ) dry port facts.

Terminal area	420.000 sqm
Stacking area	270.000 sqm
Rail tracks	12 km of rail tracks 7 x 600 m + 6 x 350 m+ 2 x 550 m

Handling equipment	5 RMG cranes 2 reach stackers 40 t (5 high) 7 reach stackers 10 t (7 high)
Truck capacity	330 trucks (long-term subcontractors)
Stacking capacity	17.500 TEUs
Capacity per year	300.000 TEUs
Capacity to operate	10 trains simultaneously
Rail Mounted Gantry Cranes	2 over 7 tracks 600m long 3 over 6 tracks 350m long
Railway station:	Praha - Uhřetěves, vlastní vlečka Metrans
Address:	METRANS, a.s. Podleská 926
GPS	CZ 104 00 Praha 10 - Uhřetěves N 50°2'19.64" E 14°34'38.493"
Operating hours	rail operation 24 / 7 incl. state holidays truck operation : MON - FRI 07:00-21:00 SAT closed, SUN 14:00-21.00

Features & Services

Customs office	✓
Reefer plugs – PTI incl.small repairs	✓
Depot for empty containers–capacity	10.000 TEUs
Covered repair shop incl.container cleaning	✓
Installment of linerbags or hangertainers	✓

- Budapest (Hungary)



Figure 54. Budapest (HU) dry port

Table 10. Budapest (HU) dry port facts

Terminal area	140.000 sqm
Stacking area	120.000 sqm
Rail tracks	6 x 650 m + 2 x 500 m
Handling equipment	2 Rail mounted gantry cranes; 4 reach stackers + 1 forklift
Truck capacity	up to 100 trucks (long-term subcontractors)
Stacking capacity	20.000 TEUs
Capacity per year	
Capacity to operate	6 trains simultaneously
Rail Mounted Gantry Cranes	2 Rail mounted gantry cranes over 6 tracks 650 m long
Railway station:	Budapest Soroksar út rendozo METRANS Konténer Kft.
Address:	Salak u. 1-39 H 1211 BUDAPEST
Operating hours	rail operation 24 / 7 incl. public holidays truck operation MON - FRI 00:00 - 24:00 SAT 00:00 - 18:00 SUN 06:00 - 24:00
Features & Services	
Customs office	✓
Reefer plugs – PTI incl. small repairs	✓
Depot for empty containers–capacity	7.500 TEU
Covered repair shop incl. container cleaning	✓
Installment of linerbags or hangertainers	✓

- Dunajska Streda (Slovakia)



Figure 55. Dunajska Streda (SK) dry port

Table 11. Dunajska Streda (SK) dry port facts

Terminal area	280.000 sqm
Stacking area	250.000 sqm
Rail tracks	5 x 650m + 4 x 550m
Handling equipment	3 Rail mounted gantry cranes 4 Reachstackers (45t) 6 Reachstackers (10t)
Truck capacity	190 trucks (long-term subcontractors)
Stacking capacity	25.000 TEUs
Capacity per year	802178 TEUs
Capacity to operate	9 trains simultaneously
Rail Mounted Gantry Cranes	3 over 5 tracks 650 m long
Railway station:	Dunajska Streda, vl.vl. Metrtrans Danubia
Address:	METRANS (Danubia), a.s. Povodska 18 SK 929 01 Dunajska Streda
GPS	N 47°58'48.45" E 17°37'55.87"
Operating hours	rail operation 24 / 7 incl. public holidays truck operation MON - FRI 00:00 - 24:00 SAT 00:00 - 18:00 SUN 06:00 - 24:00
Features & Services	
Customs office	✓
Reefer plugs – PTI incl. small repairs	✓
Depot for empty containers – capacity	15,000 TEUs
Covered repair shop incl. container cleaning	✓
Installment of linerbags or hangertainers	✓

8.4 Logistics Park Kansas City Intermodal Facility

BNSF Railway is one of North America's leading freight transportation companies, with a rail network of 32,500 route miles in 28 states and three Canadian provinces. BNSF Railway's newest state-of-the-art facility, the Logistics Park Kansas City (LPKC) Intermodal Facility is ideally located in the nation's heartland, and has been designed to accommodate the growing demands of freight rail transportation.

It consists of:

- 1,800,000 sqm
- 750,000+ annual unit capacity*
- 19,500 m of track
- 1,810 paved parking spaces

- 4,300 container stacking spots
- Eight wide-span all-electric cranes

* *1.5-million-unit capacity at full build-out*

LPKC is BNSF's only full-service logistics park in the United States, offering the combination of services:

- Domestic Intermodal Service – Container, Trailer, Expedited and Standard Service Levels
- International Intermodal Service
- Direct-rail / Carload Service

Efficiency Advantages:

- Rail is the most fuel- and resource-efficient mode of land transportation. Freight railroads transport approximately 40 percent of the nation's freight volume but reduce greenhouse gas emissions by 75 percent compared to trucks.
- BNSF is an industry leader in testing, developing and implementing green technology. And its trains are more fuel-efficient than the industry average, moving each ton of freight 500 miles on a single gallon of fuel.
- LPKC Intermodal Facility Efficiency
- BNSF doesn't stop at the rails, it also reduces emissions at its facilities. Before construction began at LPKC, BNSF participated in an extensive environmental review process resulting in these environmentally friendly features:
 - Eight all-electric wide-span cranes produce zero on-site emissions and reduce noise by:
 - Eliminating the use of standard diesel cranes for loading and unloading containers
 - Reducing the number of hostlers by stacking and moving containers
 - Decreasing diesel locomotive use by reducing switching by spanning multiple, longer loading tracks
 - Generating electricity while they work, recharging internal batteries and conserving electricity
 - Automated gate systems reduce idling, braking and utilize shutdown rules for the power units — providing optimal efficiency and enhanced security
 - Welded / continuous rail and seamless pavement reduce noise
 - Dark skylighting decreases glare and transient lighting

- Large conservation corridor buffers noise and light

Project Advantages:

- Strategically and centrally located
- Optimize your supply chain
- Master-planned distribution and
- 6,880,000 sqm of developable space warehouse development
- 1,580,000 sqm of building capacity
- Efficient movement of global goods
- Access to heavy-haul corridor
- Reduced transportation costs

8.4.1 Inland Port VIII

NorthPoint Development has a 72,000 sqm, speculative, state-of-the-art distribution center under construction at Logistics Park Kansas City (LPKC). Located in Edgerton, Kansas, a suburb southwest of Kansas City, LPKC is a 6,880,000 sqm master-planned development served by BNSF Railway's newest intermodal facility.

Inland Port VIII, can accommodate manufacturing, warehouse and distribution tenants of varying size. Inland Port VIII will be located near the entrance of BNSF's intermodal facility, which offers access to international and domestic container service along with heavy haul corridor access.



Figure 56. Inland Port VIII

Table 12. Inland Port VIII specifications

Specifications

Building Size	± 777,222 SF	Future Trailer Storage	Build-to-Suit
Availability / Divisibility	± 777,222 / 150,000 SF	Electric Service	3,000 Amps @ 480V 3P
Taxes	Estimated \$0.62 / SF (fixed)	Lighting	T-5 HO
Insurance	Estimated \$0.05 / SF	Heat	High E Gas Fired MAU's
CAM	Estimated \$0.18 / SF	Parking (expandable)	1/2,000 SF (expandable)
Dimensions	± 520' x 1,486'	Zoning	Logistics Park
Office Space	Build-to-Suit	Year Built	2016/2017
Construction	Concrete Tilt-up	Water	JC WD 7
Clear Height	36' + Outside Speed Bay	Sewer	Edgerton – New Treatment Facility
Floor	7" Concrete Slab	Electricity	Kansas City Power & Light Company
Bay Spacing	52' x 50' Loading Bays	Gas	Kansas Gas Energy
Fire Protection	ESFR	Fire Protection	JC-1
Loading	77 Dock-high (expandable); 4 drive-in	Intermodal Access	1.5 Miles to BNSF Gate
Truck Court	60' Concrete Aprons, 8" Concrete	Interstate Access	1.5 Miles to I-35

8.4.2 Inland Port XXXI

NorthPoint Development has started construction on a 35,000 sqm, speculative, state-of-the-art distribution center at Logistics Park Kansas City (LPKC) with 20,000 sqm

available. Located in Edgerton, Kansas, a suburb southwest of Kansas City, LPKC is a 6,880,000 sqm master-planned development served by BNSF Railway's newest intermodal facility.

Inland Port XXXI can accommodate manufacturing, warehouse and distribution tenants of varying size. Inland Port XXXI will be located near the entrance of BNSF's intermodal facility, which offers access to international and domestic container service along with heavy haul corridor access.



Figure 57. Inland Port XXXI

Table 13. Inland Port VIII specifications

Specifications

Building Size	± 378,022 SF	Future Trailer Storage	25 +Trailer Positions (expandable)
Availability / Divisibility	± 221,621 SF / 110,810 SF	Electric Service	1,500 Amps 480V 3P
Taxes	Estimated \$0.62 / SF (fixed)	Lighting	T-5 HO
Insurance	Estimated \$0.05 / SF	Heat	High E Gas Fired MAU's
CAM	Estimated \$0.18 / SF	Parking	1/2,000 SF (expandable)
Dimensions	± 520' x 1,486'	Zoning	Logistics Park
Office Space	Build-to-Suit	Year Built	2016
Construction	Concrete Tilt-up	Water	JC WD 7
Clear Height	32' + Outside Speed Bay	Sewer	Edgerton – New Treatment Facility
Floor	7" Concrete Slab	Electricity	KCP&L
Bay Spacing	52' x 50' Loading Bays	Gas	Kansas Gas Energy
Fire Protection	ESFR	Fire Protection	JC-1
Loading	1/10,000 SF dock-high (expandable); 3 drive-in	Intermodal Access	±2 Miles to BNSF Gate
Truck Court	60' Concrete Aprons, 8" Concrete	I-35	±2 Miles

8.4.3 Inland Port XXXII

NorthPoint Development has started construction on a 71,000 sqm, speculative, state-of-the-art distribution center at Logistics Park Kansas City (LPKC). Located in Edgerton, Kansas, a suburb southwest of Kansas City, LPKC is a 6,880,000 sqm master-planned development served by BNSF Railway's newest intermodal facility.

Inland Port XXXII can accommodate manufacturing, warehouse and distribution tenants of varying size. Inland Port XXXII will be located near the entrance of BNSF's intermodal facility, which offers access to international and domestic container service along with heavy haul corridor access.



Figure 58. Inland Port XXXII

8.4.4 The Value of Co-Location

Locating your distribution center or warehouse at Logistics Park Kansas City can:

- Substantially lower transportation costs by reducing drayage charges
- Lower fuel cost volatility (by cutting fuel consumption)
- Decrease emissions
- Improve efficiency
 - Maximize truck turns
 - Minimize the number of trucks and drivers needed
- Increase supply chain options by combining various rail services with other modes of transportation. LPKC offers:

- Domestic Container and Trailer Intermodal Service
- International Container Intermodal Service
- Direct-rail / Carload Service
- Provide enhanced security
- Increase outbound capacity by clustering equipment and services

8.4.5 Site Selection Features & Benefits

Logistics Park Kansas City (LPKC) is one of America's premier logistics facilities. By locating your facility at LPKC, you will enjoy:

- A cost-efficient solution for logistics-oriented companies focused on development
- Reduced drayage rates
- A labor-ready workforce
- Unsurpassed connectivity
- Direct use of the services at BNSF's LPKC Intermodal Facility
- Access to pre-planned and sustainable infrastructure
 - Double Diverging Diamond Interchange
 - Heavy-haul Corridor
- Benefits of Foreign Trade Zone

8.4.6 Infrastructure Surrounding LPKC

Tenants at LPKC enjoy immediate access to well-planned and long-term infrastructure that can accommodate growth for many years to come. Pre-planning by BNSF and its development partners, along with the State of Kansas, Johnson County and the City of Edgerton, has positioned LPKC as a leading location offering:

- Double Diverging Diamond Interchange at Homestead Lane, to ease traffic congestion and provide the most efficient way to enter and exit LPKC, the Double Diverging Diamond Interchange at Homestead Lane allows for quicker turns, improved traffic flow and convenient access to and from I-35, which is less than one mile from the gates of LPKC. Expansion of this key corridor to four lanes from I-35 to 191st Street improves access to LPKC.
- 191st Street & Heavy-haul Corridors, Access to LPKC is improved by widening 191st Street to two lanes with turn lanes at intersections with the potential to add two lanes in future. More than 1.5 miles are designated as a heavy-haul corridor along 191st Street between Waverly and Four Corners Roads and along Waverly Road, north of 191st, which allows shippers to move their heavyweight containers between the LPKC Intermodal Facility and their facility within the LPKC Business Park with a permit. Access to heavy-haul corridors is an extremely attractive feature, especially for agri-business exports.

- Upgraded and Sustainable Infrastructure, along with the transportation infrastructure projects, the City of Edgerton has made every effort to build sustainable infrastructure to meet tenants' needs including a newly constructed wastewater treatment facility with a 500,000 gallon per day capacity, upgraded utility improvements and water storage tower.



Figure 59. LPKC facilities

LPKC is a Foreign Trade Zone (FTZ). To accommodate international shippers, LPKC offers specifically designated areas considered to be outside the customs territory of the United States. The benefits of a FTZ may include:

- Accelerated supply chain
- Reduced merchandise processing fees
- Duty savings
- Decreased inventory tax

Incentive

To help secure the bright future of business in Edgerton, thanks to an agreement the City has with BNSF and NorthPoint Development, warehouse and distribution facilities that locate within LPKC are eligible for a 10-year net-effective 50 percent property tax abatement.

8.4.7 Container Yard / Drayage Services

Logistics parks attract truckload carriers and other support facilities that enhance the overall long-term supply chain capabilities of an area. The service and support infrastructure developing near LPKC includes private container yard facilities (CY), other equipment / capacity staging areas, carrier support facilities like truck terminals, equipment repair facilities and cross-dock or transloading facilities.

Private Container Yard Services

Container Yard Services at LPKC will include:

- Lift-on & lift-off of containers
- Container storage
- Container repair
- Storage for laden and empty containers
- Parking for chassis and trucks

Surrounding LPKC will be acres of level, well-maintained container, chassis and semi-trailer storage areas. These surface lots will accommodate multiple uses, including either grounded or wheeled operations.

8.4.8 Development Partners

- NorthPoint Development is a privately held real estate development company specializing in complex master-planned projects. NorthPoint has logistics-oriented developments in 11 markets across the United States and serves as the real estate developer for Logistics Park Kansas City (LPKC), a 1,700-acre inland distribution hub that includes a public private partnership and BNSF's newest intermodal facility. Typical discussions with prospective tenants include decreasing operating costs, matching empty containers with export loads, decreased drayage expenses and increasing utilization of domestic intermodal services. For lower volume shippers, typical savings represent 30 – 40 percent of the total costs of occupancy. For higher volume shippers, combined savings can represent the entire cost of occupancy.
- JLL is a financial and professional services firm that specializes in commercial real estate services. Our 50,000 people across 1,000 locations in 70 countries serve the local, regional and global real estate needs of corporations and investors, delivering integrated commercial real estate services built on insight and foresight, sound market research and relevant knowledge. JLL's Kansas City brokerage team has been involved in excess of 3,000 sales and leasing transactions, totaling over \$1.5 billion in value. Kevin Wilkerson and Phillip Algrim are the exclusive agents for Logistics Park Kansas City (LPKC) and are part of the JLL's Supply Chain &
- Hickey & Associates is a global site selection, public incentive advisory and labor analytics company with active projects in the Americas, Asia, Europe, Australia and Africa. Utilizing state-of-the-art tools and techniques, H&A assists businesses in determining the best location to expand, relocate or consolidate anywhere in the world. For the past 30 years, H&A has been assisting companies to secure, manage, and administer in excess of \$2 billion in Public Incentive Partnerships. Offering experience in every major sector, Hickey & Associates has developed a proprietary model that streamlines the process of incentive identification, negotiation and delivery. Their site selection and public incentives experts are based in key strategic markets to maximize your business goals with enhanced local knowledge and client service.

9 Inland Port Design

This chapter will present the implementation of the guide. A geographic position is selected and a draft is suggested.

9.1 Necessity of Building an Intermodal Station in Greece

The development of inland freight distribution systems has been an active strategy to promote the hinterland of maritime gateways around the world. Greece finds itself in a development status and a very strong economic sector is the one of trade. Since the time that the port of Piraeus started to be exploited by Cosco, the growth of the port reached the 450% of its initial trade power.

As the economy rises and more investments take place in the field of trading. Therefore, its mandatory to plan the construction of a new state to the art intermodal freight station that will be able to support the new challenges in the field of trading goods and support the new investments that take place in Greece.

9.2 Decision Making Process for Choosing the hub Position.

As we have already mentioned above, intermodal freight stations have some common characteristics concerning the geographical positions they are built. Below there is presented the location map of intermodal freight stations in US and EU.

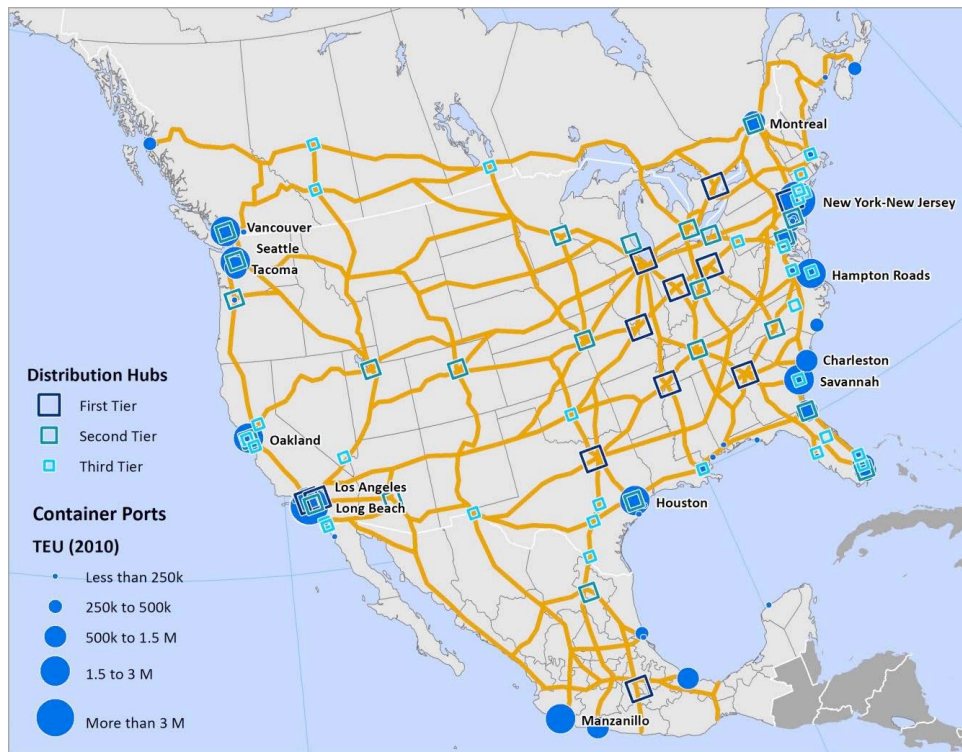

Figure 60. Main Container Ports, Trade Corridors and Distribution Hubs in North America, Cushman & Wakefield (2009).



Figure 61. Intermodal terminals & interchange points in North America, Cushman & Wakefield (2009).



Figure 62. Logistics polarisation in the Rhine-Scheldt Delta: logistics zones, trimodal dry ports, rail-based dry ports and barge-based dry ports, Notteboom (2000)

It is in Western Europe that the setting of inland terminals is the most advanced with a close integration of port terminals with rail shuttles and barge services. A large concentration of dry ports can be found around the Rhine/Scheldt delta, which is Europe's most important gateway region with a total container throughput of 23.2 million TEU in 2011, and where the function of satellite terminals is prominent (Figure 50). Almost every European port has an inland terminal strategy as a way to secure hinterland traffic.

In North America on the other hand, there have been large inland terminals since the development of the continental railway system in the late 19th century. Their setting was a natural process where inland terminals corresponded to large inland market areas, commonly around metropolitan areas commanding a regional manufacturing base and distribution system. Although exports were significant, particularly for agricultural goods, this system of inland terminals was mostly for domestic freight distribution, connecting manufacturing and resource regions.

The main difference between those two cases is that America had a higher concern about covering the need of moving the goods in the hinterland than the Europeans had. That occurred because not many region of north America had access to ports. On the other hand, Europe didn't have such a problem.

In the table below there are shown some basic differences between US and EU.

Table 14 TEU Volume in Greece

Geographical Location of Intermodal Freight Stations		
	US	EU
Lowland areas	×	×
Areas with railway infrastructure	×	×
Industrial Areas	×	×
Interchange Points	×	×
Next to ports	×	×
Hinterland	×	
Next to rivers		×

The orange region shows the difference between the two. All of the above will have a great meaning when there is a dilemma for choosing the right place in order to propose and design an intermodal freight station in territory that doesn't have one. In the Greek case the above comparison was highly decisive in order to end up in the best option.

9.2 Selecting the appropriate position

Below are presented the rail freight corridor that Greece belongs, the rail network in Greece

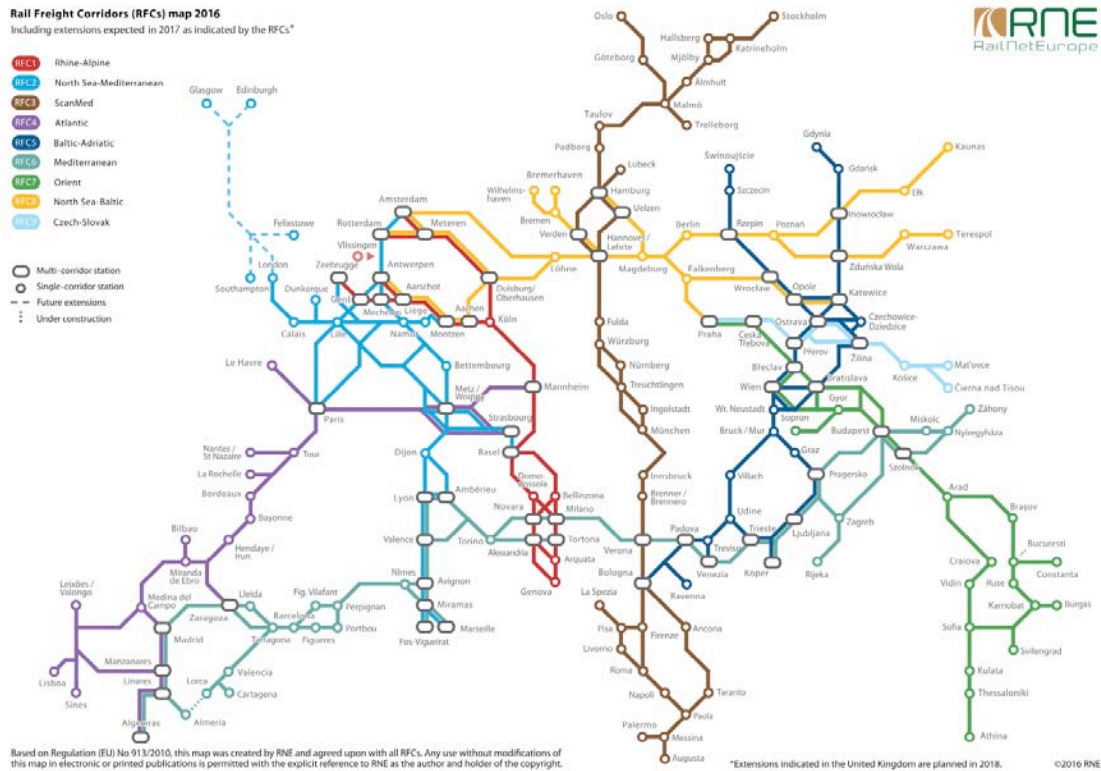

Figure 63. European Rail Freight Corridors



Figure 64. RFC 7 Members

According to rail freight corridors map (Figure 63), Greece belongs in the southeastern part (RFC 7 – Orient) of Europe. Containers are transshipped mainly via ports. Greece is an entry point that connects Asia, mainly China, with Europe. On the contrary, the role of Greece as an international crossroad in the inland rail and road transports is weak. As a result, a dry port should be close to a port to provide its service as the growth in volume of TEUs is getting bigger.

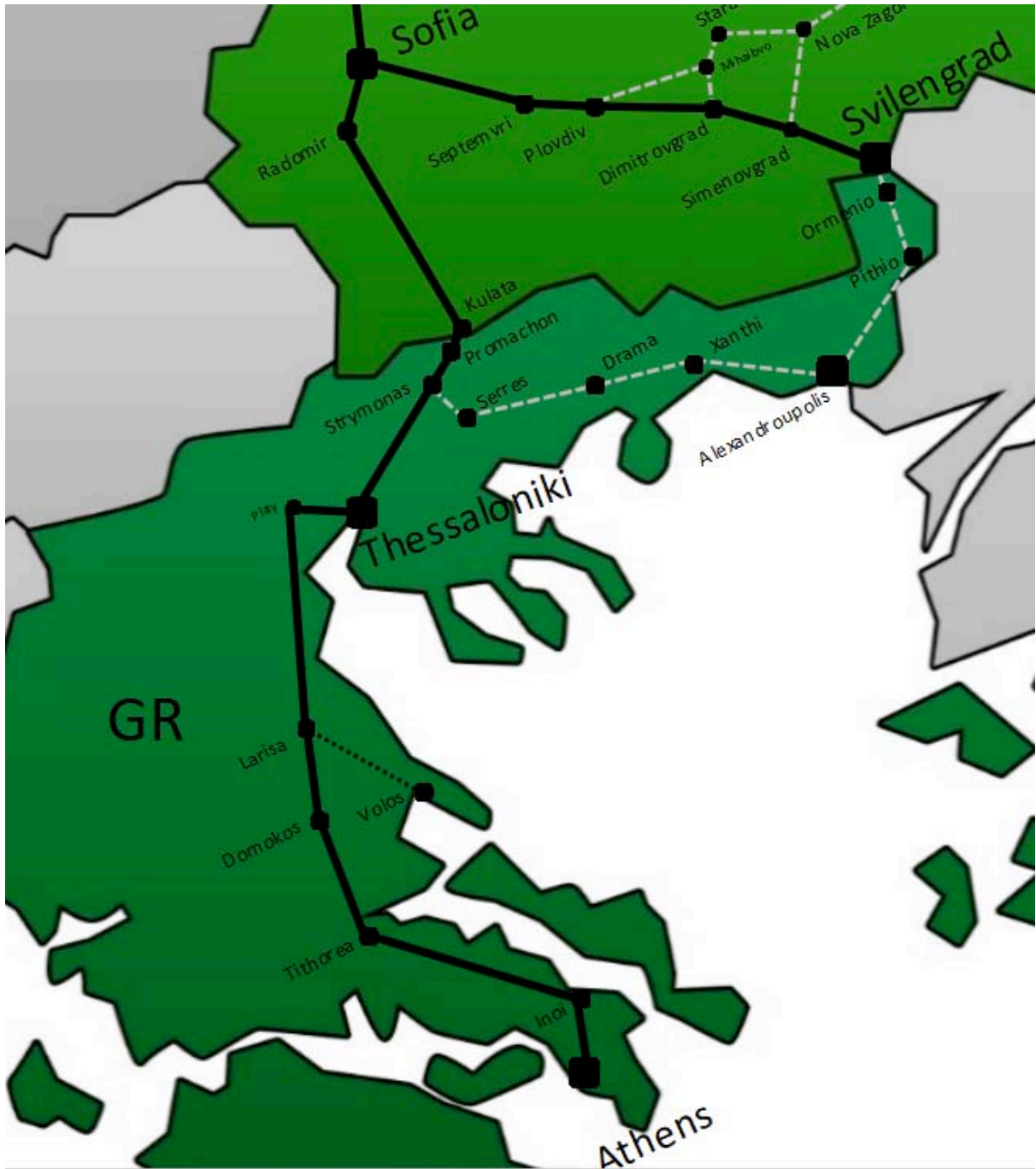

Figure 65. Rail network in Greece

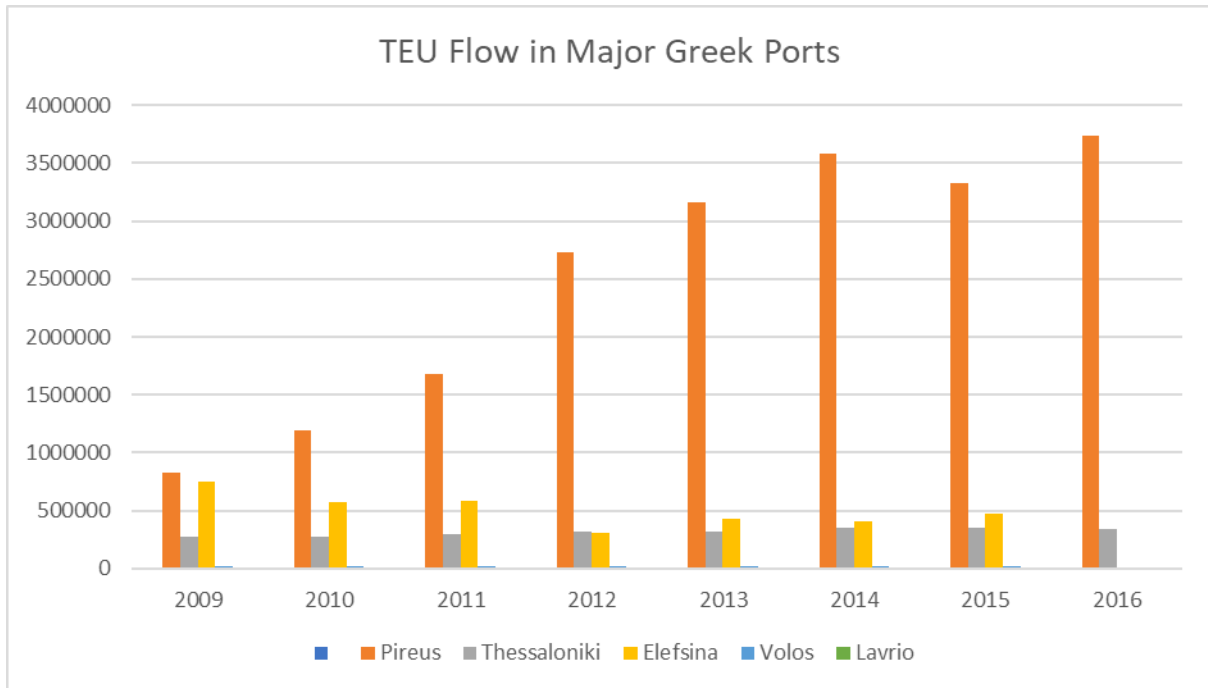

Figure 66. TEU Volume in Greece

According to the rail freight corridor, Greece belongs to the southeastern part of Europe. Containers traded in Greece are mainly supplied by its larger ports. As it can be extracted from the map, Greece is not a hub for rail and road services and the main freight import and export is being traded via ports.

Based on the above fact, it's mandatory to take into consideration the maritime freight transportation in order to design a new intermodal freight station in Greece. The figure above (Figure 66) presents the change in container traffic in the largest ports of Greece since 2009. According to these data, it is obvious that the largest freight traffic takes place in the ports of Elefsina, Piraeus and Thessaloniki. The port of Volos comes 4th in the traffic ranking without being able to compete against the three others.

Table 15. TEU Volume in Greece

	2009	2010	2011	2012	2013	2014	2015	2016
Piraeus	830,995	1,198,219	1,679,004	2,734,014	3,163,755	3,585,155	3,327,779	3,736,616
Thessaloniki	270,181	273,282	295,870	317,900	322,310	349,990	351,741	344,316
Elefsina	748,762	574,804	588,219	306,676	425,732	405,732	474,381	
Volos	16,989	19,802	16,212	23,827	17,716	17,478	19,046	
Lavrio		687	2,584	2,190	2,670	4,716	12,555	

Piraeus port container traffic is on the rise. In 2009, 830,995 TEUs were transshipped. Piraeus port had a staggering growth in flow, after the partial privatization. (67 percent were sold to Cosco). Piraeus port reached the number of 3.163.000 TEUs in 2013, with a general growth of 381 percent during the years 2009-2013., when 450 percent is the total rise since Cosco acquired a part of it through long lending procedure.

In 2017, 67 percent of the Port of Thessaloniki was sold to the highest bidder. This is a case of long term lease, till 2051 in particular. The flow in port of Thessaloniki till 2016 was

344,316 TEUs. Following the same growth pattern in five years from now flow can be raised up to 300 to 400 percent, which means 1,032,948 to 1,377,264 TEUs.

A company operating in Lavrio port (Ekol Greece) plans to invest 2 million euros for a new dock in Lavrio port. It is crucial because it will be available for docking when strong winds occur. Also, it plans to connect via rail the port of Lavrio, the port of Thessaloniki and the terminal in Aspropirgos. Also, has conversations with new owner of port of Thessaloniki to make a rail connection with Skopje and Ljubljana.

The harbors of Piraeus and Elefsina use the Thriasio center in order to move their cargo, which is located in the area of Aspropyrgos Attica. The Thriasio center supports both road and the rail network for the transshipment of freight. Thus, the best option for creating a new intermodal freight station is somewhere northern from the region of Attica. The best alternative areas would be Thessaly and Macedonia. More specifically the two options are, Thessaloniki in the region of Macedonia and Kileler in the prefecture of Larissa, as there are two appropriate areas for development.

The area of Kileler (Figures 66 & 67) is one of the two alternative proposals for the construction of the transit center. The benefits of choosing this alternative are shown below.

1. Kileler is located close to the industrial area of Volos and Larissa which means that it enables the cooperation of the two industrial areas in order to take advantage of the new intermodal facility for their benefit. The storage and movement of freight will be much cheaper and easier for the companies in those two regions.
2. Secondly, the area of Thessaly and more specifically the area of Kileler is located in the center of Greece. At the same time on one of the biggest roads of the country, the National Road of Athens - Thessaloniki (E75) passes through Kileler, fact that encourages the construction of the hub in this area. The E75 connects the southern and central Greece to the northern part of the country.
3. In Kileler there is already rail infrastructure from Trainose, which is consistent for minimizing the cost of building new rail facilities.
4. Furthermore, Kileler is located near the city of Volos and therefore is close to the commercial port. The port of Volos, as shown in the relevant chart, has been showing an increase in the past years with respect to freight traffic. An investment of this kind would mean further economic growth in the area.
5. Next to the rail station in Kileler there is a piece of land belonging to the Greek state, and in particular under the jurisdiction of Trainose and is not being utilized at the time being. This is in favor of the investment if the Greek state because it will not require additional expropriation costs or possible time delays in its acquisition.

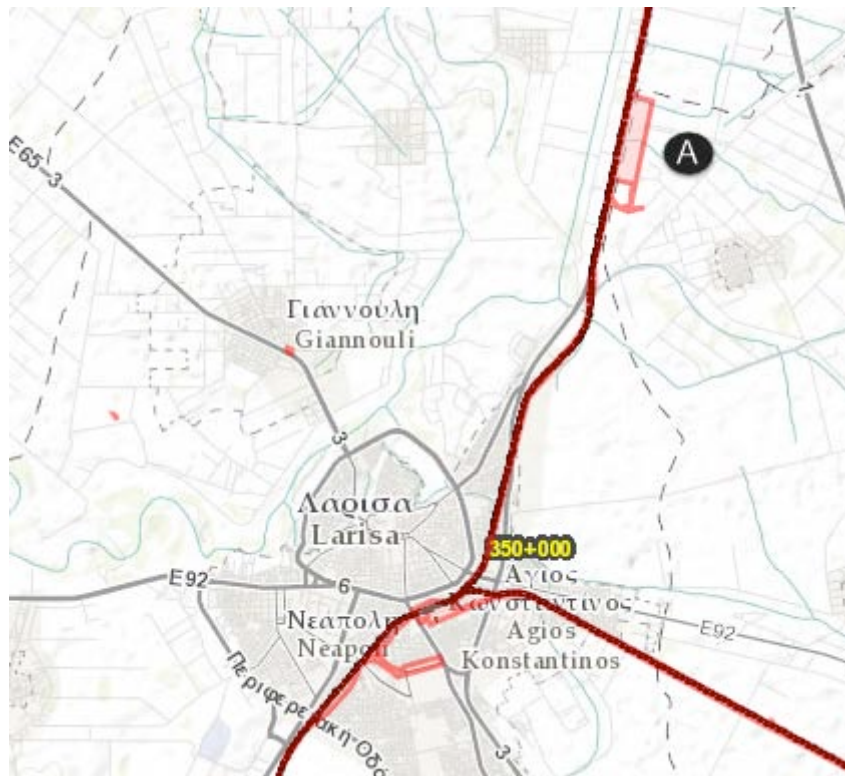

Figure 67. Area of development in Kileler, Larissa, from http://www.arcgis.com/apps/Compare/storytelling_tabbed/index.html?appid=9c32a112c1274e14af5db5ef70b67176



Figure 68. Area of development in Kileler, Larissa, from http://www.arcgis.com/apps/Compare/storytelling_tabbed/index.html?appid=9c32a112c1274e14af5db5ef70b67176

Thessaloniki (Figures 68 & 69) is the second and the best option for the establishment of the intermodal freight station, since it has the 2nd largest traffic in its port, and fulfills the following conditions.

1. Thessaloniki has an advanced industrial area. The fact that Thessaloniki has one of the largest industrial areas in Greece is in favor of the creation of a transit center as it minimizes the cost of transporting the goods in the industrial area and can potentially approach new business activities in the industrial sector while proposing a quicker and more economical way of moving products.
2. Thessaloniki is next to Egnatia Road (E90). Egnatia Road is the newest highway in Greece linking Western and Eastern northern Greece, as well as the Balkans. At the same time, it is located at the end of the E75 which enables the movement of cargo in the rest of Greece. As a result, a very large volume of goods has to pass through Thessaloniki. The transit center will take advantage of the already existing automotive infrastructure in which most of the country's goods are handled.
3. Thessaloniki is also supported by the Pan-European Road.
4. The area has an existing rail infrastructure which minimizes the cost of implementing a new network to support the transit center.
5. Thessaloniki has the second largest trading port in Greece since 2015. Based on the development data of the port of Thessaloniki, it is clear that significant funds are being invested in the development of the trade and in particular the development of Thessaloniki's commercial harbor.
6. In the vicinity of the port there is a piece of land belonging to the Greek state and specifically to the jurisdiction of the Greek Army. This area is not used at the time being. This camp is already linked to the country's existing rail network, which minimizes the cost of deploying the transit center.

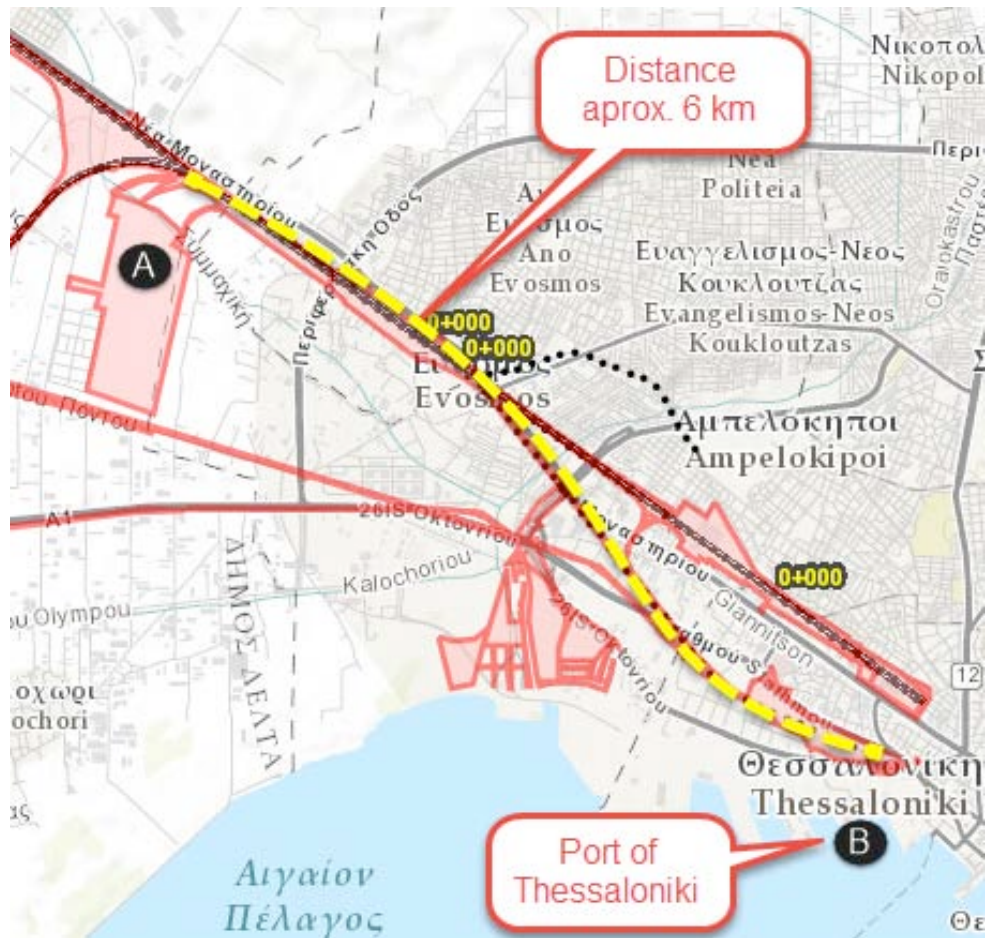

Figure 69. Area of development in Thessaloniki, from http://www.arcgis.com/apps/Compare/storytelling_tabbed/index.html?appid=9c32a112c1274e14af5db5ef70b67176



Figure 70. Area of development in Thessaloniki, from http://www.arcgis.com/apps/Compare/storytelling_tabbed/index.html?appid=9c32a112c1274e14af5db5ef70b67176

Based on the above data, and having in mind all the information from the US and EU intermodal freight stations the area of Thessaloniki is preferred for the construction of the transit center. The Greek case scenario is more similar to the European theme because Greece is a country with less hinterland than seaside areas. Thus, it does not fit with the US theme. Thessaloniki is the second biggest port of Greece and need support with the railways and the new facilities in order to have a chance in the competition.

9.2 Services

In general Container Yard Services should include:

- Lift-on & lift-off of containers
- Container storage
- Container repair
- Storage for laden and empty containers
- Parking for chassis and trucks
- Warehouse for cross docking and storage

- Wagon storage and wagon maintenance
- Wagon hire and wagon hook/pull
- Container handling – rail to road, road to rail
- Container storage
- 24/7 capability operating hours
- RFID technology
- Automated Gates
- Rest station for Drivers
- Warehouse refrigerators

9.3 Costs

The question of costs in combined transport has always been a “grey” area. There is no universally accepted cost methodology in the railway sector and very little information is available in relation to the breakdown of operating costs. In many cases the rail prices include large over-heads, internal cross-subsidies or are determined according to the highest price that the market can bear (Cantos et al., 1999). Furthermore, no cost data exists for terminals operating on the basis of pilot technologies.

For this reason, a “custom-made” cost calculation scheme has been particularly developed with the aim of comparing the cost-effectiveness of different alternatives. This cost scheme incorporates the elements presented in (table 15) below.

Table 16. Building Costs of Intermodal Station

BUILDING COSTS	
Infrastructure	1. Land acquisition
	2. Track formation
	3. Rail tracks
	4. Switches and signals
	5. Crane track
	6. Road lanes
	7. Gates
	8. Buildings
	9. Lighting
	10. Fencing
	11. Well as handling and other terminal equipment
Maintenance and power	
Personnel for the pure terminal operations	
Train access procedures	The costs for these procedures are determined according to access and handling procedures associated with the simulated technological solution
rolling stock and car-go “inspection”	
Cost of truck service time in the terminal	It is calculated taking into account the mean truck dwell time in the terminal.

9.4 Preliminary economic evaluation

Intermodal Terminal Costing Model

Using modelling principles, an economic engineering model was developed to simulate costs for an intermodal facility. The model provides decision makers with an estimate of start-up and annual costs. Moreover, it provides insight into traffic volumes needed to make such a facility feasible. The model was developed to evaluate costs for intermodal facilities with varying sizes, equipment configurations, equipment types, and traffic levels. The model consists of changeable fixed and variable cost sections to replicate different sizes and configurations of facilities which allows for scenario analysis and provides a range of investment levels as well as unit costs for decision making purposes.

Base Case Facility Assumptions

Facility size is based on the median size and track length of BNSF facilities nationwide. The Dilworth, MN, facility is the railway's smallest, considering land area and track length, car spots, and parking. Based on median size of facilities it could be estimated that a facility with 44 acres and 8,600 feet of track could serve the area with ample parking space, car spots, truck manoeuvring and parking. It is assumed that two powered switches are needed and two internal switches would be required. Fencing the perimeter of 44 acres on three sides would require 3,960 feet of fence. It is assumed that all 44 acres would be paved. However, some areas may need concrete to support the weight of the lifter as it manoeuvres to load and unload TOFC/COFC units. It was assumed there would be a need for 15 work lights and 20 reefer hook-ups. A 2,500-square-foot building would be built for office and storage space. This facility would need one lifter, two hustlers, two chassis, and one forklift. There would be a manager and four yard employees. Table 4 shows the initial assumptions along with possible options.

The model developed here is only for illustrative purposes and does not represent any intent of a facility type or size.

Table 17. Estimated investment expenditure for the base case facility

Land acres	44	Cost per acre	\$3,000.00
Feet of track	8,600	Cost per foot of track	\$100.00
No. of powered switches	2	Cost of powered switches	\$130,000.00
No. of fence feet	3,960	Cost of fence per foot	\$10.00
Acres of pavement	44	Cost per acre	\$10,000.00
No. of work lights	15	Cost of lights	\$10,000.00
No. of reefer hookups	20	Cost of reefer hookup	\$2,000.00
Square feet of building	2,500	Cost per square foot	\$50.00
Feet of water line	1,500	Cost per foot	\$10.00
Feet of sewer line	1,500	Cost per foot	\$20.00
No. of lifters	2	Cost of lifter	\$500,000.00
No. of hustlers	2	Cost of hustlers	\$50,000.00
No. of forklifts	1	Cost of forklifts	\$25,000.00
No. of Chassis	2	Cost of chassis	\$5,000.00
Facility Estimated Useful Life (Years)	20	Equipment est. useful life (Years)	15
Tax rate	5%	Insurance	.5%
Interest rate	8%	Estimated facility life	20 Years
Maintenance and repair	Variable		

Table 17 shows the estimated investment expenditure for the base case facility. As the table shows, a base case facility capable of handling 100,000 lifts per year is estimated to cost in excess of \$2 million.

Table 18. Investment for the Hypothetical Intermodal Facility

Land	\$132,000
Track	\$860,000
Powered Switches	\$260,000
Internal Switches	\$320,000
Fence	\$39,600
Building	\$187,500
Office Equipment	\$32,500
Lighting	\$150,000
Reefer Hookups	\$40,000
Water Line	\$20,000
Sewer Line	\$30,000
Equipment (1 lifter, 2 hustlers, 2 chassis, 1 Forklift)	\$635,000
Total	\$3,026,600

Table 18 estimates annual fixed and variable costs for the base case intermodal facility. Estimated fixed costs include facility and equipment depreciation, return on investment, taxes, insurance, management, accounting expenses, building expenses and maintenance. Variable costs include worker wages, benefits, and fuel. As the table shows, it is estimated that such a facility would cost over \$800,000 per year to operate and maintain.

Table 19. Estimated Annual Operating Costs for Intermodal Terminal

Total Annual Costs	
Fixed	
Land Track & Building	\$95,664
Equipment	\$33,867
T,I,MR,ROI	\$299,950
Management	\$101,200
Building Expense	\$15,225
Accounting	\$2,500
Total Fixed	\$548,406
Variable	
Wages	\$202,400
WC & SS	\$24,288
Benefits	\$30,360
Fuel	\$35,360
Total Variable	\$292,408
Annual Costs	
Total	\$840,814

Highest cost items under fixed costs include taxes, insurance, maintenance, and return on investment (ROI). The next highest fixed cost is management. Management may be a variable cost because it could change, but it is fixed in this case because it is a necessary part of a facility. The work force may be reduced, but management is necessary. In the model, management

costs are based on the number and wages of employees. Under the variable costs, the highest category is wages. It is estimated to require at least four full-time employees to run a facility of this size.

The base case estimates facility costs and annual operating costs. Costs may be decreased using used equipment, less land and labor, or by using existing track or other changes. ROI makes up almost \$210,000 of the estimated annual operating costs. ROI includes the opportunity cost for dollars invested, covers interest and principal payments, and/or provides return to investors.

An estimate of the costs for maintaining and operating a facility per lift is provided. This is useful in making an assessment of the traffic levels necessary to make such a facility feasible. Table 7 provides an estimate of the total costs per lift for the base case facility at various lift volumes. As the table shows, the total estimated costs per lift decrease with increased volume.

Table 20. Model Sensitivity Cost Per Lift at Different Annual Lift Volumes

Lifts/YR	Fixed Costs/lift	Variable Cost/lift	Total Costs/lift
5000	\$110	\$2.60	\$112.28
10000	\$55	\$2.60	\$57.44
15000	\$37	\$2.60	\$39.16
20000	\$27	\$2.60	\$30.02
25000	\$22	\$2.60	\$24.53
30000	\$18	\$2.60	\$20.88
35000	\$16	\$2.60	\$18.26
40000	\$14	\$2.60	\$16.31
45000	\$12	\$2.60	\$14.78
50000	\$11	\$2.60	\$13.56
55000	\$10	\$2.60	\$12.57
60000	\$9	\$2.60	\$11.74
65000	\$8	\$2.60	\$11.03
70000	\$8	\$2.60	\$10.43
75000	\$7	\$2.60	\$9.91
80000	\$7	\$2.60	\$9.45
85000	\$6	\$2.60	\$9.05
90000	\$6	\$2.60	\$8.69
95000	\$6	\$2.60	\$8.37
100000	\$5	\$2.60	\$8.08
105000	\$5	\$2.60	\$7.82
110000	\$5	\$2.60	\$7.58
115000	\$5	\$2.60	\$7.36

Some insight into the types of volumes that would be necessary to support a facility might be obtained by comparing an average revenue per lift to the costs per lift.¹⁰ Leeper, et. al (1996) estimate that the lift revenues at Dilworth, MN, are in the range of \$10 to \$15. If these numbers are put in current dollars using the GDP Implicit Price Deflator, the range is \$10.94 to \$16.41 in 2001 prices.

Given the potential difficulty in generating a large amount of traffic for such a facility, any new potential facility would likely need to provide other types of services in addition to intermodal container service. It is important to remember that these numbers are for one specific type of facility, with specific assumptions regarding the costs of different inputs. It may be possible to configure a facility in a way that results in lower costs per lift.

Model Sensitivity to Variables

Capital expenditures in equipment provide small increments of annual operating costs. Adding \$50,000 in equipment costs adds less than \$8,000 to annual operating costs.

It is important to note that these cost estimates and average revenue estimates are reasonable estimates given the information we have. However, the point where average revenue per lift is equal to cost per lift from this model should not be considered as a solid break-even point. Rather, the numbers are illustrative of a range of traffic where such a facility may be feasible.

9.5 Proposal for Construction

According to the information that was available and taking into consideration the huge evolution of the port of Piraeus we thought as more appropriate for the region of Thessaloniki to propose an intermodal freight station with the perspective and the power of this of Prague Uhrineves (Czechia).

- Prague-Uhrineves (Czechia)



Figure. Prague-Uhrineves (CZ) dry port

Table. Prague-Uhrineves (CZ) dry port facts.

Terminal area	420.000 sqm
Stacking area	270.000 sqm
Rail tracks	12 km of rail tracks 7 x 600 m + 6 x 350 m+ 2 x 550 m
Handling equipment	5 RMG cranes 2 reach stackers 40 t (5 high) 7 reach stackers 10 t (7 high)
Truck capacity	330 trucks (long-term subcontractors)
Stacking capacity	17.500 TEUs
Capacity per year	300.000 TEUs
Capacity to operate	10 trains simultaneously

Rail Mounted Gantry Cranes	2 over 7 tracks 600m long 3 over 6 tracks 350m long
Railway station:	Praha - Uhřetěves, vlastní vlečka Metrans
Address:	METRANS, a.s. Podleská 926 CZ 104 00 Praha 10 - Uhřetěves
GPS	N 50°2'19.64" E 14°34'38.493"
Operating hours	rail operation 24 / 7 incl. state holidays truck operation : MON - FRI 07:00-21:00 SAT closed, SUN 14:00-21.00

Features & Services

Customs office	✓
Reefer plugs – PTI incl.small repairs	✓
Depot for empty containers–capacity	10.000 TEUs
Covered repair shop incl.container cleaning	✓
Installment of linerbags or hangertainers	✓

10 Conclusion

This chapter will present the conclusions and suggestions about further research in the future.

10.1 Conclusion

The setting of dry ports has been a dominant paradigm in the development of hinterland transportation as the growth of maritime transportation and its economies of scale have placed pressures on the inland segment of freight distribution.

The development of dry ports around the world has clearly underlined an emerging functional relation of port terminals and their hinterland. Based upon their regional setting, dry ports assume a variety of functions with co-location with logistical zones a dominant development paradigm. They are likely to be more important elements within supply chains, particularly through their role of buffer where containerized consignments can be cheaply stored, waiting to be forwarded to their final destinations.

Greece is a country that has the perspective of turning into a big competitor in the European market if there is strong will to invest in trading. The geographical position of Greece gives the ability to overcome whatever problems occur and start visualize its position amongst the biggest ports of Europe.

This thesis was a preliminary research of the way that intermodal freight stations are organized and work both in Europe and the US. There was a final effort to propose an idea for a new intermodal freight station in Thessaloniki in order to cover the needs of freight transport mainly in northern Greece and channeling the products that come to the port of Thessaloniki in the rest of Europe as long as assisting the operations of Piraeus.

10.2 Further research

Further research should focus on:

- Technical - economical study in order to calculate the exact costs of constructing the intermodal station in Thessaloniki
- Constructing a simulation model in order to calculate the upcoming demand for the port of Thessaloniki
- Evaluate the existing financing legislation in order to claim a subsidy from the state of Greece.

11 References

- Theo Notteboom and Jean-Paul Rodrigue, "Inland Terminals within North American and European Supply Chains", *Transport and Communications Bulletin for Asia and the Pacific* No. 78, 2009 , pp 1-2,25-28
- UIC, "Report on Combined Transport in Europe 2007", 2009
- Ballis, A. and Golias, J. (2002), "Comparative evaluation of existing and innovative rail-road freight transport terminals", 2002
- DIOMIS, (2009), "Benchmarking Intermodal Rail Transport in the United States and Europe", Dirk Steenken; Stefan Voß; Robert Stahlbock (2004). "Container terminal operation and operations research - a classification and literature review". *OR Spectrum*. Berlin / Heidelberg: Springer-Verlag. 26 (1): 3–49
- Levinson, Marc. (2006) "Sample Chapter for Levinson, M.: *The Box: How the Shipping Container Made the World Smaller and the World Economy Bigger*". *The Box: How the Shipping Container Made the World Smaller and the World Economy Bigger*. Princeton University Press
- Lewandowski, Krzysztof (2016). "Growth in the Size of Unit Loads and Shipping Containers from Antique to WWI". *Packaging Technology and Science*. 29 (8-9): 451–478.
- Heins, Matthew (2013). "2". *The Shipping Container and the Globalization of American Infrastructure*. University of Michigan. p. 15
- Hesse, M. (2008). *The city as a terminal: The urban context of logistics and freight transport*. Aldershot, UK:
- Ashgate. Levinson, M. (2006). *The box: How the shipping container made the world smaller and the world economy bigger*. Princeton: Princeton University Press.
- Notteboom, T., & Rodrigue, J-P. (2009). The future of containerization: Perspectives from maritime and inland freight distribution. *Geojournal*, 74(1), 7–22.
- Rimmer, P. J., & Comtois, C. (2009) China's container-related dynamics, 1990–2005. *Geojournal*, 74(1), 35–50.
- John Tomlinson, (2009), "History and Impact of the Intermodal Shipping Container ", Pratt Institute
- Pinder, D. & Slack, B. (Eds.) (2004). *Shipping and ports in the twenty-first century: Globalization, technical change and the environment*. London: Routledge
- Broeze, F. (2002). *The globalisation of the oceans: Containerisation from the 1950s to the present*. St. Johns, NF, Canada: International Maritime Economic History Association.
- Cudahy, Brian J., (2006), "The Containership Revolution: Malcom McLean's 1956 Innovation Goes Global". *TR News*. (c/o National Academy of Sciences). Number 246
- Rushton, A., Oxley, J., Croucher, P. (2004). "The Handbook of Logistics and Distribution Management". Kogan Page: London.

Leitner, Sara Jean; Harrison, Robert (2001). The Identification and Classification of Inland Ports. Center for Transportation Research, The University of Texas at Austin. p. 69.

"Container Handbook". (2006) German Insurance Association.

"Banana box slip a worry".(2008) Lloyd's List Daily Commercial News. Informa Australia.

Upper Great Plains Transportation Institute, (2007) "Feasibility of a Logistics Center Including Container/Trailer Intermodal Transportation in the Fargo/Moorhead Area", North Dakota State University,