



UNIVERSITY OF THESSALY, GREECE

DESIGN AND IMPLEMENTATION OF RESOURCE ALLOCATION
PROTOCOLS IN WIRELESS NETWORKS, UTILIZING TESTBED
EXPERIMENTATION PLATFORMS

Doctor of Philosophy
in
Electrical & Computer Engineering
by
APOSTOLOS APOSTOLARAS
June 2014

Dissertation Committee:

Prof. Leandros Tassiulas

Prof. Aikaterini Housti

Associate Prof. Spyros Lalis

*Apostolos Apostolaras: Design and Implementation of Resource Allocation Protocols
in Wireless Networks, Utilizing Testbed Experimentation Platforms, © June 2014*

The Dissertation of Apostolos Apostolaras is approved by:

Committee Chairperson

Dept. of Electrical & Computer Engineering,
University of Thessaly, Greece

Dedicated to my Family.

ABSTRACT

DESIGN AND IMPLEMENTATION OF RESOURCE ALLOCATION PROTOCOLS IN WIRELESS NETWORKS, UTILIZING TESTBED EXPERIMENTATION PLATFORMS

by APOSTOLOS APOSTOLARAS

UNIVERSITY OF THESSALY, GREECE

PROF. LEANDROS TASSIULAS CHAIRPERSON

Particularly for the *cooperative scheduling problem*, a novel communication architecture is proposed which considers the exploitation of intermediate relays. Relays are employed for forwarding information to the final destination when networking conditions do not benefit the direct transmissions from source to destination. Our architecture improves drastically networking performance by incorporating advanced mechanisms from optimization theory. As a result, sophisticated scheduling and resource allocation techniques for *unicast* and *multicast* scenarios are activated so that a wireless network to attain desired power performance vs. networking delay trade-offs. A primitive design of our architecture is the ability offered to operators to fine-tune and balance the network operation through a control knob that achieves power savings with an induced cost in the networking delay. The above design feature is enabled by effectively exploiting information storage capabilities and power efficient scheduling. Finally, testbed experimentation conducted in NITOS testbed has revealed a significant reduction in the transmission power with the use of our cooperative architecture. Moreover, we identify ways to incorporate the same architecture principles in LTE-A cellular networks. To this end, we assume wireless mesh networking by evolving the user equipment to act as a relay in a 3GPP LTE-A system. Thus, interconnecting two eNBs with mobile user equipment. Wireless mesh networking in LTE networks has recently become a focal point of interest in the emerging scenarios for 5G technology. We propose specific scenarios where this architecture can be effectively applied and illustrate the corresponding results from the experimentation that was conducted in the OpenAirInterface.

For the *data offloading problem*, we study a framework for toggling LTE-A cellular mobile users to WiFi mesh networks. Mobile network operators can lease these mesh networks to offload their traffic and reduce their servicing cost. In this context, we determine the most-costly users to the cellular network and we design a routing policy that the mesh network can employ so as to serve the offloaded traffic with the minimum possible cost. Moreover, the reimbursement offered by the operator should be dispensed to the different mesh users, according to their contribution and added-value significance. We address this issue by employing the Shapley value profit sharing rule, which ensures the participation of the mesh nodes in this joint task.

Περίληψη

**Σχεδιασμός και Υλοποίηση Πρωτοκόλλων Ανάθεσης
Πόρων σε Ασύρματα Δίκτυα
με τη Χρήση Πειραματικών Διατάξεων**

Απόστολος Αποστολάρας

Τα τελευταία χρόνια η έρευνα με βάση τον πειραματισμό με χρήση ειδικών διατάξεων κερδίζει περισσότερο έδαφος και γίνεται ιδιαίτερα δημοφιλής μεταξύ των ερευνητών που ασχολούνται με ασύρματα τηλεπικοινωνιακά δίκτυα. Οι ερευνητές για να αξιολογήσουν τα μοντέλα τους αναζητούν τρόπους και μεθόδους για υλοποιήσεις σε πραγματικά συστήματα προκειμένου να επιτύχουν υψηλή ακρίβεια και ορθότητα κατά τον πειραματισμό. Η τρέχουσα ερευνητική πρακτική στα τηλεπικοινωνιακά δίκτυα χρησιμοποιούσε έως τώρα την θεωρητική ανάλυση και κατόπιν την προσομοίωση για την αξιολόγηση ενός νέου ασύρματου πρωτοκόλλου ή μιας πολιτικής δρομολόγησης.

Βασιζόμενοι στα παραπάνω, οι ερευνητές είχαν ως στόχο την απόκτηση σημαντικών πληροφοριών σχετικά με την απόδοση και την αποτελεσματικότητα των μοντέλων τους, αξιολογώντας τα αποτελέσματα που προέκυπταν κατά την προσομοίωση. Τα εν λόγω αποτελέσματα αφορούν συνήθως μετρικές απόδοσης όπως ο ρυθμός μετάδοσης της πληροφορίας, η χρονική καθυστέρηση, η κατανάλωση ισχύος, κλπ. Ωστόσο, με αυτή την πρακτική συνήθως υιοθετούνται απλουστεύσεις στην μοντελοποίηση προκειμένου να έχουμε εύχρηστα και προσπελάσιμα μοντέλα στην προσομοίωση.

Ενώ με τη χρήση προσομοιώσεων υπάρχει η δυνατότητα να χρησιμοποιηθούν ακριβέστερα μοντέλα, οι ερευνητές πρακτικά περιορίζονται από την πολυπλοκότητα του λογισμικού της προσομοίωσης καθώς και από την περιορισμένη γνώση που διαθέτουν για το ασύρματο περιβάλλον μετάδοσης της πληροφορίας. Χαρακτηριστικά αναφέρουμε τυπικούς περιορισμούς οι οποίοι περιλαμβάνουν την ανακριβή αναπαράσταση του ασύρματου μέσου μετάδοσης, την απλοποίηση της διαδικασίας συγχρονισμού των συσκευών επικοινωνίας και την απλούστευση των πολλών πτυχών που έχουν να κάνουν με το υπολογιστικό κόστος. Λόγω των παραπάνω περιορισμών, οι ερευνητές επικεντρώνονται τα τελευταία χρόνια στη μελέτη των ασύρματων

συστημάτων επικοινωνίας μέσω πειραματισμού με χρήση πειραματικών διατάξεων. Αυτή η νέα τάση στον πειραματισμό και την μελέτη των ασύρματων δικτύων προκάλεσε την δημιουργία και την ανάπτυξη διαφόρων πειραματικών διατάξεων σε πανεπιστημιακά ιδρύματα και ερευνητικά κέντρα ανά την υφήλιο. Για τους παραπάνω λόγους και με σκοπό τον πειραματισμό αρχικά σε ασύρματες τεχνολογίες επικοινωνίας (και μετέπειτα και σε ενσύρματες) δημιουργήθηκε η πειραματική διάταξη NITOS, (Network Implementation Testbed using Open Source software) η οποία βρίσκεται στο κτίριο του Τμήματος Ηλεκτρολόγων Μηχανικών και Μηχανικών Η/Υ του Πανεπιστημίου Θεσσαλίας.

Καθώς η ανάγκη για περισσότερη ακρίβεια στον πειραματισμό των ασύρματων δικτύων γίνεται περισσότερο επιτακτική, στο **πρώτο μέρος** αυτής της *διατριβής* περιγράφουμε τις προσπάθειες για την δημιουργία και την ανάπτυξη μίας υποδομής για πειραματισμό σε ασύρματα δίκτυα επικοινωνιών. Η διάταξη NITOS έχει δημιουργηθεί με σκοπό να προσφέρει όλα τα απαραίτητα μέσα για την διευκόλυνση του πειραματισμού σε δίκτυα επικοινωνιών και είναι ανοιχτή, και προσβάσιμη εξ αποστάσεως συνεχώς (*url: <http://nitlab.inf.uth.gr>*). Στην διάταξη γίνεται χρήση λογισμικού ανοικτού κώδικα από τους εγγεγραμμένους χρήστες με σκοπό τον πειραματισμό. Αρχικά ο στόχος μας δεν περιορίστηκε στο να μιμηθούμε τη σύγχρονη πρακτική που συνήθως περιλαμβάνει τη δημιουργία της πειραματικής διάταξης και κατόπιν την χρήση της μεταξύ των διαχειριστών της πλατφόρμας ή των τοπικών χρηστών του αντίστοιχου ερευνητικού ιδρύματος ή πανεπιστημίου. Αντιθέτως, προσβλέποντας στην αποδοτικότερη αξιοποίηση των διαθέσιμων πόρων και στην ευκολία στην πρόσβαση από εξωτερικούς ερευνητές, καταφέραμε να αναπτύξουμε νέα εργαλεία διαχείρισης και να εξελίξουμε τα ήδη υφιστάμενα εργαλεία ελεύθερου λογισμικού και ανοικτού κώδικα, έτσι ώστε να απλοποιηθούν και να επιταχυνθούν οι φάσεις του πειραματισμού. Βασικός στόχος τέθηκε η διευκόλυνση στη διαδικασία πειραματισμού που συνήθως μη προχωρημένοι χρήστες ηλεκτρονικών συστημάτων αποφεύγουν.

Επιπλέον, οι τρεις κύριοι πυλώνες σε αυτή την προσπάθεια δημιουργίας της πειραματικής διάταξης NITOS ήταν να επιτευχθεί για τους χρήστες ένα περιβάλλον που να προσφέρει τα απαραίτητα μέσα για ορθή *επαλήθευση, επανάληψη και επανεκτέλεση* των πειραμάτων. Η διάταξη NITOS συνεχώς εξελίσσεται και φιλοξενεί ετερογενείς και διαφορετικές τεχνολογίες τηλεπικοινωνιών και αισθητήρων προσφέροντας δυνατότητες πειραματισμού σε απομακρυσμένους χρήστες. Επιπλέον, αποτελεί την κύρια ασύρματη πλατφόρμα πειραματισμού για το ευρωπαϊκό έργο OpenLab FP7. Επίσης πολλά ευρωπαϊκά ερευνητικά έργα έχουν χρησιμοποιήσει και συνεχίζουν να χρησιμοποιούν τις υποδομές της με σκοπό τον πειραματισμό για την εξαγωγή ασφαλών συμπερασμάτων και την αξιολόγηση των ερευνητικών αποτελεσμάτων τους. Αναφέρουμε επίσης ότι η χρήση της υποδομής και της οργάνωσης λειτουργίας της διάταξης NITOS έχει υιοθετηθεί από άλλες παρόμοιες διατάξεις όπως αυτή που βρίσκεται στο ερευνητικό ινστιτούτο Eurecom το οποίο αναπτύσσει μία υλοποίηση ανοικτού λογισμικού για ασύρματα κυψελωτά δίκτυα τέταρτης γενιάς 4G.

Στο **δεύτερο** μέρος αυτής της *διατριβής*, μελετούμε διάφορα προβλήματα σε ασύρματα δίκτυα. Η αξιολόγηση της απόδοσης των μοντέλων και των τεχνικών που προτείνονται, έγινε στη πειραματική διάταξη NITOS. Η προσέγγισή μας συνδυάζει την θεωρητική ανάλυση για τα μοντέλα υπό εξέταση με την πραγματική υλοποίηση τους στην πειραματική διάταξη και τέλος την αξιολόγηση τους. Το πρώτο πρόβλημα με το οποίο ασχολούμαστε αφορά την συνεργασία των χρηστών σε ασύρματα δίκτυα σε επίπεδο πακέτου πληροφορίας. Μελετάμε συνεργατικές μεθόδους που μπορεί να εφαρμοστούν τόσο σε δίκτυα τεχνολογίας WiFi όσο και σε κυψελωτά δίκτυα κινητής τηλεφωνίας, όπως το LTE-A (4G). Προτείνουμε μια νέα αρχιτεκτονική η οποία σε επίπεδο πακέτου χρησιμοποιεί αναμεταδότες οι οποίοι συνεργάζονται για την μετάδοση της πληροφορίας. Το δεύτερο πρόβλημα με το οποίο ασχολούμαστε αφορά την αποφόρτιση των κυψελωτών δικτύων μεταφέροντας κάποιους χρήστες σε παρακείμενα δίκτυα WiFi. Μελετάμε τις προϋποθέσεις υπό τις οποίες η αποφόρτιση των χρηστών μπορεί να προσφέρει οφέλη τόσο στους κινητούς χρήστες και τους τηλεπικοινωνιακούς παρόχους όσο και στους χρήστες που αποτελούν το WiFi δίκτυο. Σχεδιάζουμε ένα πλαίσιο που καθορίζει τους κινητούς χρήστες που πρέπει να αποφορτίσουν το κυψελωτό δίκτυο, με βάση το κόστος της ενέργειας που θα υποστούν οι σταθμοί βάσης της κινητής τηλεφωνίας (eNB) λαμβάνοντας υπόψιν την εξυπηρέτηση των αιτημάτων τους.

Πιο συγκεκριμένα, όσο αφορά το πρώτο πρόβλημα *συνεργατικής επικοινωνίας*, προτείνουμε μια νέα αρχιτεκτονική η οποία εκμεταλλεύεται την παρουσία αναμεταδοτών για να προωθήσουν την πληροφορία στον τελικό προορισμό. Η χρησιμοποίηση των αναμεταδοτών είναι ωφέλιμη, όταν οι συνθήκες δικτύωσης δεν ωφελούν τις άμεσες μεταδόσεις από την πηγή στον προορισμό. Η αρχιτεκτονική που προτείνουμε βελτιώνει δραστικά την απόδοση της επικοινωνίας κάνοντας χρήση μηχανισμών από τη θεωρία βελτιστοποίησης. Ως αποτέλεσμα, έξυπνες τεχνικές δρομολόγησης και κατανομής των πόρων του δικτύου ενεργοποιούνται έτσι ώστε να επιφέρουν ένα ισοζύγιο μεταξύ της κατανάλωσης ισχύος και της καθυστέρησης στην εξυπηρέτηση της επικοινωνίας. Μελετάμε σενάρια που περιλαμβάνουν unicast και multicast μεταδόσεις.

Ένα βασικό πλεονέκτημα της προτεινόμενης αρχιτεκτονικής είναι η δυνατότητα που προσφέρει στους παρόχους να ρυθμίζουν το ισοζύγιο της λειτουργίας του δικτύου μέσω ενός διακόπτη ελέγχου που επιτυγχάνει εξοικονόμηση στην κατανάλωση ενέργειας με ένα κόστος το οποίο αντιστοιχεί σε αύξηση της καθυστέρησης στην εξυπηρέτηση της επικοινωνίας. Το παραπάνω πλεονέκτημα οφείλεται στην αποτελεσματική αξιοποίηση των δυνατοτήτων αποθήκευσης των πακέτων σε ουρές και στην ομοιογενή ενεργοποίηση των χρονοδρομολογήσεων. Ο πειραματισμός στην διάταξη δοκιμών NITOS αποκάλυψε σημαντική μείωση της κατανάλωσης ισχύος για μετάδοση με τη χρήση συνεργατικών τεχνικών.

Επιπλέον, ερευνήσαμε τρόπους για να ενσωματώσουμε την ίδια αρχιτεκτονική σε κυψελωτά δίκτυα τεχνολογίας LTE-A. Για να πραγματοποιηθεί το παραπάνω θα πρέπει να α-

ναβαθμίσουμε τους κινητούς χρήστες να μπορούν μεταφέρουν πληροφορία λειτουργώντας σαν αναμεταδότες σε μία τοπολογία πλέγματος. Η ασύρματη δικτύωση πλέγματος σε δίκτυα LTE-A έχει πρόσφατα αποτελέσει σημείο ενδιαφέροντος για την αναδυόμενη τεχνολογία 5G. Προτείνουμε και αναδεικνύουμε συγκεκριμένα σενάρια, όπου αυτή η αρχιτεκτονική μπορεί να εφαρμοστεί αποτελεσματικά και παραθέτουμε τα αντίστοιχα αποτελέσματα από τον πειρατισμό που διεξήχθη στο OpenAirInterface.

Για πρόβλημα της *αποφόρτισης δεδομένων*, μελετήσαμε ένα πλαίσιο για την μετακίνηση κινητών χρηστών από LTE -A κυψελωτά δίκτυα σε ασύρματα δίκτυα πλέγματος τεχνολογίας WiFi . Οι πάροχοι κινητής τηλεφωνίας δύναται να μισθώσουν αυτά τα δίκτυα πλέγματος προκειμένου να απαλλαγούν από την αυξημένη συμφόρηση δεδομένων με σκοπό να μειώσουν το κόστος εξυπηρέτησης. Επιθυμούμε να προσδιορίσουμε τους πιο δαπανηρούς χρήστες στο δίκτυο κινητής τηλεφωνίας οι οποίοι είναι κοστοβόροι για τον σταθμό βάσης και σχεδιάζουμε μια πολιτική δρομολόγησης που το δίκτυο πλέγματος μπορεί να χρησιμοποιήσει, έτσι ώστε να εξυπηρετήσει την κίνηση των χρηστών που μετακινήθηκαν με το ελάχιστο δυνατό κόστος. Επιπλέον, η χρηματική αποζημίωση που προσφέρει ο πάροχος θα πρέπει να διανέμεται στους διάφορους χρήστες-κόμβους του δικτύου πλέγματος, ανάλογα με τη συμβολή του καθενός στην εξυπηρέτηση των κινητών χρηστών που μετακινήθηκαν. Το ζήτημα αυτό το αντιμετωπίζουμε χρησιμοποιώντας τον κανόνα της ανταλλαγής κέρδους/κόστους του Shapley.

PUBLICATIONS

The results, the ideas and figures are included in the following publications:

Journals and Magazines

- [J.1.] Dimitris Giatsios, Apostolos Apostolaras, Thanasis Korakis, and Leandros Tassiulas. *“Methodology and tools for measurements on wireless testbeds: The nitos approach.”* In *Measurement Methodology and Tools*, pages 61–80. Springer, 2013.
- [J.2.] Giovanni Di Stasi, Roberto Bifulco, Stefano Avallone, Roberto Canonico, Apostolos Apostolaras, Nikolaos Giallelis, Thanasis Korakis, and Leandros Tassiulas. *“Interconnection of geographically distributed wireless mesh testbeds: Resource sharing on a large scale.”* *Ad Hoc Networks*, 9(8):1389–1403, 2011.

Conferences

- [C.1.] Apostolos Apostolaras, Navid Nikaein, Raymond Knopp, Thanasis Korakis, Iordanis Koutsopoulos and Leandros Tassiulas. *“Evolving UEs for L2 Collaborative Packet Forwarding.”* submitted, ACM Conference on emerging Networking EXperiments and Technologies, CoNEXT 2014
- [C.2.] Apostolos Apostolaras, George Iosifidis, Konstantinos Chounos, Thanasis Korakis and Leandros Tassiulas. *“C2M: Mobile Data Offloading to Mesh Networks.”* to be presented in IEEE Global Communication Conference, Globecom, 2014
- [C.3.] Mahmoud Hadeif, Apostolos Apostolaras, Jim O’Reilly, Alain Mourad, and Belkacem Mouhouche. *“Cooperative multicast resource allocation strategy.”* In *Proceedings of the IEEE Wireless and Communications Networking Conference (WCNC)*, 2014
- [C.4.] Mahmoud Hadeif, Apostolos Apostolaras, Jim O’Reilly, Alain Mourad, Belkacem Mouhouche, Iordanis Koutsopoulos, Thanasis Korakis, and Leandros Tassiulas. *“Energy aware buffer aided cooperative relay selection.”* In

- [C.5.] Apostolos Apostolaras, Kostas Choumas, Ilias Syrigos, Iordanis Koutsopoulos, Thanasis Korakis, Antonios Argyriou, and Leandros Tassiulas. "On the implementation of relay selection strategies for a cooperative diamond network." In *Personal Indoor and Mobile Radio Communications (PIMRC), 2013 IEEE 24th International Symposium on*, pages 1753–1758. IEEE, 2013.
- [C.6.] Mahmoud Hedef, Apostolos Apostolaras, Alain Mourad, Jim Oreilly, Iordanis Koutsopoulos, Thanasis Korakis, and Leandros Tassiulas. "Energy efficiency performance evaluation of back-pressure driven cooperative relay selection for wimax systems." In *Proceedings of the 6th International ICST Conference on Simulation Tools and Techniques*, pages 258–267. ICST (Institute for Computer Sciences, Social-Informatics and Telecommunications Engineering), 2013.
- [C.7.] Angelos-Christos Anadiotis, Apostolos Apostolaras, Dimitris Syrivelis, Thanasis Korakis, Leandros Tassiulas, Luis Rodriguez, Ivan Seskar, and Maximilian Ott. "Towards maximizing wireless testbed utilization using spectrum slicing." In *Testbeds and Research Infrastructures. Development of Networks and Communities*, pages 299–314. Springer, 2011.
- [C.8.] Giovanni Di Stasi, Roberto Bifulco, Francesco Paolo D'Elia, Stefano Avallone, Roberto Canonico, Apostolos Apostolaras, Nikolaos Giallelis, Thanasis Korakis, and Leandros Tassiulas. "Experimenting with p2p traffic optimization for wireless mesh networks in a federated omf-planetlab environment." In *Wireless Communications and Networking Conference (WCNC), 2011 IEEE*, pages 719–724. IEEE, 2011.
- [C.9.] Angelos-Christos Anadiotis, Apostolos Apostolaras, Dimitris Syrivelis, Thanasis Korakis, Leandros Tassiulas, Luis Rodriguez, and Maximilian Ott. "A new slicing scheme for efficient use of wireless testbeds." In *Proceedings of the 4th ACM international workshop on Experimental evaluation and characterization*, pages 83–84. ACM, 2009.
- [C.10.] Dimitris Syrivelis, Angelos-Christos Anadiotis, Apostolos Apostolaras, Thanasis Korakis, and Leandros Tassiulas. "Tlqap: A topology and link quality assessment protocol for efficient node allocation on wireless testbeds." In *Proceedings of the 4th ACM international workshop on Experimental evaluation and characterization*, pages 27–34. ACM, 2009.

Demos and Posters

- [D.1.] Apostolos Apostolaras, Kostas Choumas, Ilias Syrigos, Giannis Kazdaridis, Thanasis Korakis, Iordanis Koutsopoulos, Antonios Argyriou, and Leandros Tassiulas. *“A demonstration of a relaying selection scheme for maximizing a diamond network’s throughput.”* In *Testbeds and Research Infrastructure. Development of Networks and Communities*, pages 408–410. Springer Berlin Heidelberg, 2012.
- [D.2.] Apostolos Apostolaras, Dimitris Syrivelis, Thanasis Korakis and Leandros Tassiulas *“Achieving Efficient Resource Allocation on Non-RF Isolated Wireless Testbed Deployments.”* In the proceedings of *Future Network and Mobile Summit 2010, Florence, Italy, June 2010*.
- [D.3.] Apostolos Apostolaras, Vasileios Miliotis, Nikos Giallelis, Dimitris Syrivelis, Thanasis Korakis and Leandros Tassiulas, *“A Demonstration of a Management Tool for Assessing Channel Quality Information in Wireless Testbeds.”*, In the proceedings *Tridentcom 2010, Berlin, Germany, May 2010*.
- [D.4.] Angelos-Christos Anadiotis, Apostolos Apostolaras, Dimitris Syrivelis, Thanasis Korakis and Leandros Tassiulas, *“A Slicing Scheme for Efficient Use of Testbed’s Resources”* In the proceedings of *MobiCom 2009, Beijing, China, September 2009*.
- [D.5.] Angelos-Christos Anadiotis, Apostolos Apostolaras, Dimitris Syrivelis, Thanasis Korakis, Leandros Tassiulas, Luis R Rodriguez, Ivan Seskar, and Maximilian Ott. *“A demonstration of a slicing scheme for efficient use of testbed’s resources.”* *Demo-Wintech (September 2009)*, 2009.

In addition, our research efforts within the same period led to the following publications that are not directly related to this thesis

Journals and Magazines

- [J.3.] Konstantinos P Tsoukatos, Maria-Pinelopi Chrisanthopoulou, and Apostolos Apostolaras. *“Cross-layer antenna beamforming and power control in wireless uplinks.”* *Wireless personal communications*, 51(3):399–409, 2009.

Conferences

- [C.11.] Vassileios Miliotis, Apostolos Apostolaras, Thanasis Korakis, Zhifengh Tao, and Leandros Tassiulas. *“New channel allocation techniques for power*

efficient wifi networks.” In *Personal, Indoor and Mobile Radio Communications Workshops (PIMRC Workshops), 2010 IEEE 21st International Symposium on*, pages 347–351. IEEE, 2010.

ACKNOWLEDGMENTS

This thesis represents the culmination of research that was conducted towards my PhD Degree from the Department of Electrical & Computer Engineering, University of Thessaly, Greece. Completing this PhD study looks like the end of a long journey pacing up and down. I want to thank my *Prof. Leandros Tassioulas* for guiding me through this journey and everyone else who contributed in making those years a wonderful experience.

I am indebted to *Leandros Tassioulas* not only for advising me and giving me the chance to participate in many European Research projects, but also for motivating me in research and work. I express my gratitude to him for his guidance, support but even more for his fruitful criticism. I am also indebted to *Thanasis Korakis* for mentoring me and for shaping my research position. To him I own the way to comprehend the essence of things. Highlighting the significance of concerns sometimes is tougher than constructing and making them operational. His belief in me, his enthusiasm, and his support were essential for me to realize my potential. I am also grateful to *Iordanis Koutsopoulos* for raising me the standards high, making me delve into the detail and stimulating my work with his critique and appraisal. To *Navid Nikaein* I want to express my sincere thanks for supporting me and having the patience to teach me and show me new things. His continuous support and appreciation during my internship were extremely valuable. It was a big honor for me to collaborate with him.

Moreover, I would like to thank all my friends and lab-mates. Particular thanks go to the NITLab staff *Angelos-Christos Anadiotis, Dimitris Giatsios, Stratos Keranidis, Nikos Giallelis, Kostas Choumas, Giannis Kazdaridis, Donatos Stavropoulos, Vassilis Maglogiannis, Virgilios Passas, Ilias Syrigos, Harris Niavis, Kostas Katsalis, Nikos Makris, Giannis Igoumenos, Pavlos Bassaras, Aris Dadoukis and Kostas Choumos..* Special thanks also to *Lazaros Gkatzikis, Vassilis Sourlas, Paris Flegkas, Giorgos Paschos, Dimitris Syrivelis and Giorgos Iosifidis.* I would also like to thank *Christina Madelou* and *Stavroula Magklavera* for their help and support all this period.

Last but not least, I am grateful to my family. I have no words to express them my gratitude for their invaluable presence and support in my life. I dedicate this dissertation to them.

CONTENTS

PRELUDE	1
1 INTRODUCTION	3
1.1 Motivation	3
1.1.1 Part I - Testbed Development	5
1.1.2 Part II - Testbed Experimentation	9
1.2 Synopsis	12
I TESTBED DEVELOPMENT	15
2 TOWARDS MAXIMIZING WIRELESS TESTBED UTILIZATION USING SPECTRUM SLICING	17
2.1 Introduction	18
2.2 Related Work	20
2.3 Wireless Testbed Managerial Framework	21
2.4 Scheduling Experiments on Wireless Testbeds	22
2.4.1 Spectrum Slicing	23
2.4.2 Allocating Resources - Slices	23
2.4.3 Implementation	25
2.5 Slicing in Action - Usage Statistics	30
2.5.1 Testbed Description	30
2.5.2 Usage Statistics	31
2.6 Conclusions	33
2.7 Future Work	34
3 TLQAP: A TOPOLOGY AND LINK QUALITY ASSESSMENT PROTOCOL	37
3.1 Introduction	38
3.2 TLQAP Protocol	40
3.3 System Implementation	42
3.3.1 Network Stack Support	42
3.3.2 Management Framework Support	44
3.4 Evaluation	49
3.4.1 Testbed Description	49
3.4.2 Using an existing bandwidth measurement tool	50
3.5 NITOS Connectivity Tool	51
3.5.1 Experiments and Results	52

3.6	Related Work	55
3.7	Conclusion	56
II TESTBED EXPERIMENTATION		57
4	ON THE IMPLEMENT. OF RELAY SEL. FOR DIAM. NET.	59
4.1	Introduction	60
4.2	Related Work	63
4.3	Network Model	65
4.3.1	Data Transmission and Queueing	66
4.3.2	Definition of Problem Optimization Objectives	67
4.4	Optimization Framework	68
4.5	Wi-Fi Implementation	69
4.5.1	Implementation Methodology	70
4.5.2	Design of a TDMA Frame	72
4.5.3	CSMA Protocol Suppression	74
4.5.4	Algorithm Implementation	75
4.6	Click and Wireless Driver Implementation	76
4.6.1	The User-level Cooperative Relaying Click Router (CRCR)	76
4.6.2	Packet Forwarding Flow from Source to Destination (T_3 interval)	78
4.6.3	Enabling Control Actions for Scheduling (T_1 and T_2 intervals)	80
4.6.4	Modifying the Radiotap Header to Support per Packet Power & Rate Configuration	81
4.7	Experimental Results	83
4.7.1	1 st Experiment	85
4.7.2	2 nd Experiment	86
4.7.3	3 rd Experiment	87
4.8	Conclusion	89
5	TOWARDS EVOLVED UE-5G - COOPERATIVE LTE-A	91
5.1	Introduction	92
5.1.1	Motivation and Scope of this Work	94
5.2	Explore for New Use Cases	96
5.2.1	Moving Cells	96
5.2.2	Small Cells	97
5.3	Architecture	98
5.3.1	LTE Mesh Network Overview	98
5.3.2	Virtual Overlay - Enable Mesh Networking	99
5.3.3	Procedures	101

5.4	Performance Evaluation	110
5.4.1	OpenAirInterface Emulation	110
5.4.2	Experimentation	111
5.5	Related Work	113
5.6	Conclusions	114
6	C2M: MOBILE DATA OFFLOADING TO MESH NETWORKS	117
6.1	Introduction	118
6.1.1	Motivation	118
6.1.2	Methodology and Contributions	119
6.2	Related Work	122
6.3	Background and Model	123
6.4	Offloading Decision Framework	126
6.4.1	Cost Sharing Policy	129
6.5	Performance Evaluation	131
6.5.1	LTE-A and WiFi Mesh Networks System Setup	132
6.5.2	Experiments	134
6.6	Conclusions	137
	EPILOGUE	139
7	CONCLUSIONS AND FUTURE WORK	141
7.1	Summary of the Contributions	141
7.1.1	Developing a wireless testbed framework to facilitate instrumental experimentation	141
7.1.2	Unleash the hidden potential of wireless communications through cooperative relaying and data forwarding	142
7.1.3	Evolve 5G Infrastructure for enabling disruptive future radio networks with relays	143
7.1.4	Wireless Data Offloading: To Disrupt Contemporary Wireless Communications	144
7.2	Future Work and Open Research Problems	144
	III APPENDIX	147
A	APPENDIX TEST	149
A.1	Lyapunov Optimization Analysis	149
	BIBLIOGRAPHY	151

LIST OF FIGURES

Figure 1	Thesis Overview.	4
Figure 2	Classification of Experimentation Methods.	7
Figure 3	Cisco Mobile Data Traffic Forecast [63].	10
Figure 4	NITOS Scheduler Node Selection	23
Figure 5	NITOS Scheduler Resource Reservation	26
Figure 6	NITOS Nodes	31
Figure 7	Slicing performance for a 5-month period, compared to the simple allocation policy simulator results for exactly the same workload.	32
Figure 8	<i>TLQAP</i> header.	41
Figure 9	<i>TLQAP</i> in the Network Stack: a) incoming path, b) outgoing path	43
Figure 10	ORBIT-Like Nodes	48
Figure 11	NITOS Connectivity Tool	52
Figure 12	Link Quality for node 4	53
Figure 13	<i>TLQAP</i> and <i>Iperf</i> PDR measurements at nodes 2-9 on a free channel and fixed rate. The transmitter is node 1	53
Figure 14	Average channel 6 utilization by testbed external devices for 2 consecutive weeks. (measured at each node between 11:00a.m and 11:20a.m)	54
Figure 15	<i>TLQAP</i> measured delay for inspecting link of 9 nodes on 14 channels and 9 different rates	55
Figure 16	Relay Selection policy: Controller $\mathbf{a}(t)$ enables communication on particular links each time. Red dotted lines indicate active schedules.	66
Figure 17	Packet collisions occurring when parallel transmission are activated.	71
Figure 18	Packet collision due to limited control access on the wireless card firmware.	72

- Figure 19 Feasible schedules are denoted with red lines. Each transmission per hop is enabled on different channel in order to avoid collisions when parallel transmissions occur. 73
- Figure 20 TDMA frame for the cooperative diamond network. 75
- Figure 21 The solid red circle indicates the extended transmission coverage range in a WLAN. Wireless nodes belonging on a WLAN act as forwarders, forming canonical diamonds to assist networking when conditions are insufficient to benefit direct transmission on the cell-edge nodes. Each diamond can be activated i.e., in a round-robin way, one by one, for avoiding extra collisions. 78
- Figure 22 CRCR Architecture in Source/Destination: Click elements are interconnected so that to enable relaying support and packet forwarding. 79
- Figure 23 CRCR Architecture in Relays: Click elements are interconnected so that to enable relaying support and packet forwarding. 80
- Figure 24 **1st Experiment:** (a) Received Throughput at Node D and (b) Packet Losses for Different Values of *Iperf* for Coop/MT, Random and Direct Transmission Policies, (b) Packet Losses for Different Values of *Iperf* for Coop/MT, Random and Direct Transmission Policies, **2nd Experiment:** (c) Received Throughput and (d) Packet Loss in Coop/MT Policy, for Different Values of Network-Layer (Click Buffer) Queue Size. 84
- Figure 25 **3rd Experiment:** Power minimization, (a) Total average power consumption and (b) Total average queue size vs. V parameter. 90
- Figure 26 Evolving the future Radio Access Networks (RANs): Evolved UEs (eUEs) are leveraged to become active network elements, providing backhaul access to core-isolated cells and realizing diverse communication paths. 92
- Figure 27 Network Topology: Moving, small and core-isolated cells exploit eUE-enabled multipoint connectivity to access backhaul, when either non-ideal X2-air interfaces cannot be effectively utilized to inter-connect eNBs or wired interfaces are infeasible or too costly to be deployed. 94
- Figure 28 An Overlay Mesh Network of eNBs. 99

Figure 29	eUE MAC layer architecture and collaborative logical channels: The functional blocks <i>aggregation</i> , <i>forwarding</i> , <i>reporting</i> and <i>queuing</i> and <i>co-scheduling</i> allow for buffer-aided collaborative packet forwarding to interconnect isolated eNBs. 103
Figure 30	Collaborative Transmission over a virtual link. eUEs adopt a flexible protocol stack so as to be able to associate to two eNBs and perform efficiently L2 packet forwarding. 106
Figure 31	OAI Measurement Results of a LTE wireless mesh network enabled by eUEs. 108
Figure 32	Logical topology for the performance evaluation scenario: A VL is setup to interconnect two eNBs with the aid of 4 eUEs. Each eUE maintains a forwarding table of CO-RNTIs so as to identify the VL and the respective MAC buffers. 111
Figure 33	OAI Measurement Results of an eUE experiencing multiple eNB communication. 113
Figure 34	An LTE-A macrocell serving mobile users that are partially covered by a mesh network. 120
Figure 35	Mesh Network Architecture. Some nodes may have AP for serving local traffic and/or Internet access. 125
Figure 36	Wireless Mesh Experimentation Topology: (left) NITOS interior building testbed setup. (right) Optimal flows for mobile users A and B (Kbits). 133
Figure 37	Wireless Mesh Network Link Capacities (Kbps). 134
Figure 38	Offloading power consumption savings. 136
Figure 39	Power consumption per cellular user due to offloading. 136
Figure 40	Mesh Network Servicing Region, for users A and B. 136
Figure 41	MFP Optimal Solution, $D_A = 10, D_B = \{0, 206\}$. 137

LIST OF TABLES

Table 1	Experimentation Methods Comparison	7
---------	------------------------------------	---

Table 2	Testbed Operational Features	8
Table 3	Maximum-Throughput.	69
Table 4	Power-Conservation.	69
Table 5	Power-Minimization.	70
Table 3	Received Throughput at Node D for Different Values of <i>Iperf</i> for Coop/MT, Random and Direct Transmission Policies.	86
Table 4	Packet Losses for Different Values of <i>Iperf</i> for Coop/MT, Random and Direct Transmission Policies.	87
Table 5	Received Throughput & Packet Loss in Coop/MT Policy, for Different Values of Network-Layer (Click Buffer) Queue Size.	88
Table 6	Measured Total Time Average Power Consumption (Watt) & Time Average Value of (Click Buffer) Queue Size.	90
Table 7	LTE-A TDD System Configuration.	110
Table 8	LTE-A FDD System Configuration.	131
Table 9	Shapley Values: Profit Sharing.	137

LISTINGS

Listing 1	Radiotap Header.	83
-----------	------------------	----

PRELUDE

INTRODUCTION

1.1 MOTIVATION

Over the last few years we are witnessing a drift in the research community for experimentation-based research. Researchers and experimenters seek ways to validate their models with real system implementations in order to achieve high accuracy and precision capturing real world settings. From one hand, the current research practice has considered the theoretical analysis and the simulation for the evaluation of a new wireless protocol or a policy/technique. Relying on them the researchers have aimed at obtaining important information about performance evaluation and efficiency in terms of various metrics such as throughput, delay, power consumption, etc. However, in order to have analytically tractable models, several simplifications of the real world have to be made.

While the simulations have the ability to incorporate more general models, researchers are practically limited by the complexity of the simulation software and their limited knowledge of the wireless environment. Some specific limitations of the simulation approach in depicting a real wireless network include inaccurate representation of the wireless medium, simplification of synchronization issues that occur in wireless terminals and ignorance of several aspects such as the computational overhead. Due to the above limitations, researchers have focused in the last few years on the studying of wireless schemes through implementing them on real platforms. This new trend in wireless networks has triggered the birth and evolution of several wireless testbeds around the globe.

Although the provision of testbeds can become a remedy against the simulation defects, testbed experimentation itself poses challenges that can in some cases cause inconsistencies and inaccuracies. Factors such as time relevance or hardware and software compatibility can have such confounding features that can lead in lack of precision and deception during experimentation. Moreover, those confounding factors can also be a product of the different and variant

tools that a user/experimenter is called to handle properly. Alleviating those factors is of paramount importance for testbed provision and experimentation services support. One of the goals in this work is to facilitate a testbeds' instrumentation and evolve the experimentation procedure by enabling a systematic experimental methodology. This Thesis consists of two parts that are strongly related to each other and aim at close interaction with experimenters. An overview of the organization of this Thesis is illustrated in Fig. 1. Relying on this organization, we give an extensive summary below.

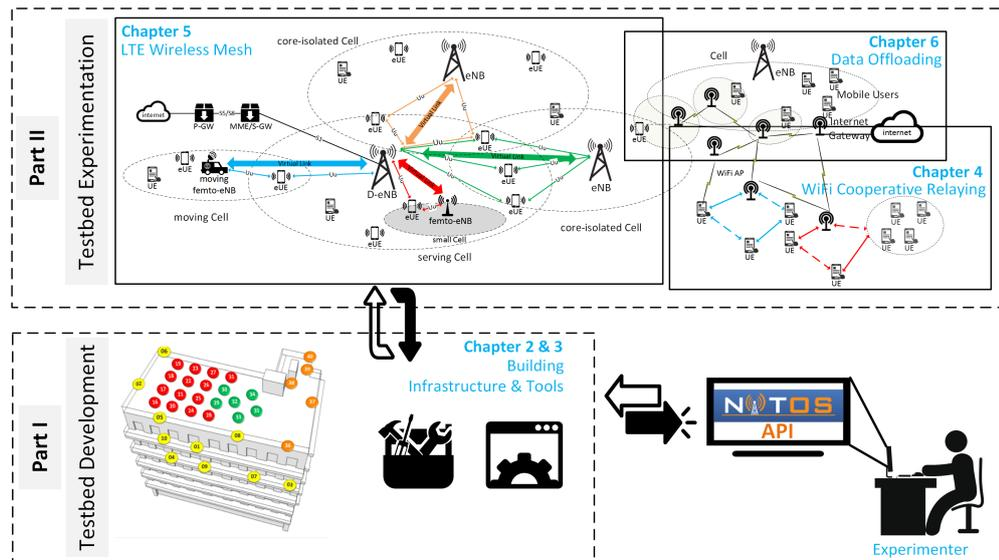

Figure 1: Thesis Overview.

As the need for realistic wireless experimentation becomes prominent, the **first part** of this *Thesis* describes the efforts for developing (deploying and evolving) a wireless testbed infrastructure. Our scope was not limited to imitate the contemporary practice that usually considered the provision of resources among the administrators of the testbed or the local users of the respective research institute or university. Instead, we aimed at moving beyond and achieve efficient utilization of the testbed resources. We managed to develop and evolve existing free and open-source software tools so as to simplify and accelerate the experimentation phases. Our focus aimed at the provision of ease in the experimentation procedure that usually frightened and alienated non-advanced linux/systems users from real experimentation.

In the **second part** of this *Thesis*, we study two different networking problems that were evaluated upon the wireless testbed infrastructure. Our approach combines both theoretical model design with real testbed implementation and evaluation. The first problem under consideration deals with user cooperation

in wireless networks. We study cooperative schemes that can be applied in WiFi networks and contemporary cellular network technologies such as LTE-A (4G). To this end we propose a novel architecture for packet-level cooperative forwarding and scheduling. The second problem under consideration deals with the hot topic of data offloading from cellular to WiFi networks. We study the conditions under which data offloading can provide benefits both to users and operators. We design a framework that determines which mobile users should be offloaded, based on the energy cost incurred to the cellular base stations (eNB) for serving their demands.

1.1.1 Part I - Testbed Development

We rethink the standard operation of a wireless testbed, in order to deploy a wireless testbed infrastructure characterized by a user-oriented twist. The building of functional wireless networking system prototypes and the deployment of the respective large scale experimentation, although they have become a standard research practice among many researchers, they pose significant challenges that deal with testbed management and control. To that end, wireless testbed support has a significant role: *“to provide users with an efficient environment that will simplify development, and conduct of experimentation as well as the evaluation of observed results”*.

Getting inspired by the above principles, we have deployed NITOS (Network Implementation Testbed using Open Source software) so as to offer means for easing the process in wireless testbed experimentation. NITOS wireless testbed has been established and built in the premises of the University of Thessaly and it is open and remotely-accessible 24/7 providing its resources for experimental purposes (*url: <http://nitlab.inf.uth.gr>*). Open Source and custom-made software can be utilized, modified and tested upon the NITOS hardware facilities. Initially, the gist of NITOS wireless testbed was the experimentation with WiFi technology. Since then, it has been evolved and now incorporates different wireless and wired technologies (WiFi, WiMAX, LTE-A, sensors, OpenFlow, SDN), being available to researchers, for remote experimentation.

Filling the Gap between Theory and Practice: Nothing can make a researcher/experimenter in wireless networks wonder - the state of an intense brain-teaser in which he finds himself when his certainties fall to pieces; when the assumptions that he has adopted (usually following the current practices in the literature) and the designs that he has modeled and proved on the pa-

per fail shortly to reveal the correct and many times expected results. Before identifying the reason why this can happen and why results cannot be straightforwardly obtained when implementing the designed model, the researcher struggles to fathom and revisits his model again and again to determine any possible missing parameter that might toggle his model from the state of being inefficient to operational. At this particular point the experimenter identifies the gap that separates the theory from practice when math equations indicate the correct solution but the real implementation apparently not.

Of course, there is always the possibility that the experimenter to make a mistake. However, without ignoring the researcher's inattentive oversight or coding erratums, the need for a framework that can offer sufficient methods to a researcher so as to assist him with the experimentation is rather important. This framework should allow the researcher to select the resources that best fit in his model for a particular scenario under consideration. In addition, it will also aid the researcher at assessing the wireless experimentation environment so as to be able to estimate better the performance of his models. In addition, a researcher having the flexibilities offered for systematic experimentation by a testbed control and management framework, can have all the essential means to detect and avoid possible errors, to identify scenarios and perform comprehensive and qualitative analysis of the results.

While moving from simulation to real testbed experimentation much more realism rather than abstraction is considered. As real experimentation is considered as more accurate and can offer consistent results that can lead researchers to safe inferences, simulation and emulation offer a more scalable environment for experimentation at a cost of an induced imprecise model representation. However, since the real wireless environment is not likely to be fully controlled when experimenting, offering the flexibility to a researcher to handle and instrument efficiently his experimentation by reproducing, repeating and verifying the same scenario will be of paramount importance. In Fig. 2, we illustrate a classification on validation of the current experimentation methods, and we also provide some exemplary cases of simulators, emulators and real testbeds. A short comparison the experimentation methods is also given in Table. 1.

The Need to Manage and Maintain Testbed Systems: Most of the ongoing testbed deployments maintain a pilot profile, with a main emphasis on supporting the experimentation part focusing on the provision of various technologies for validating protocols and algorithms and leaving the management part behind. This effect happens regularly in small testbed deployments in academia

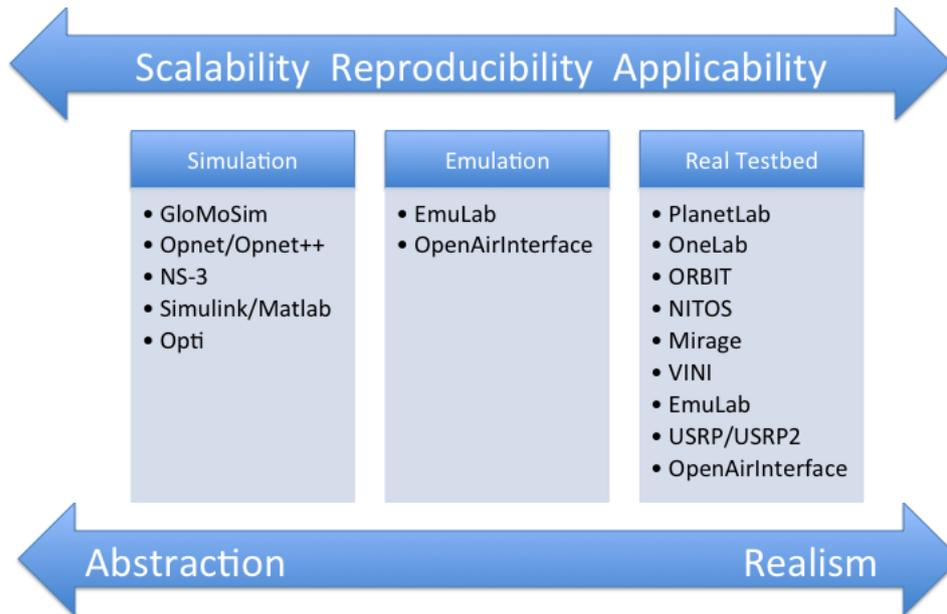

Figure 2: Classification of Experimentation Methods.

Table 1: Experimentation Methods Comparison

Experimentation Methods	Characteristics
<i>Simulation</i>	Closed environment No interaction with external environment System/Network is abstracted at all
<i>Emulation</i>	Semi-Open environment Both Real and Modeled Network/System elements are used
<i>Real Testbed</i>	Open environment All elements are real

where the notion of supporting and maintaining an experimentation infrastructure is restricted to the scope of supporting the needs of a limited local research group. However, once a testbed deployment scales up beyond pilot trials to sustain more users and multiple technologies, management challenges are likely to arise, impeding the normal operation of the testbed.

While in the early days of wireless testbeds deployments, the administrators were using common (or even no) tools to manage the testbed, nowadays, with the continuously increasing demand, they have appealed to more sophisticated solutions which can efficiently manage the testbed resources. Therefore, testbed management frameworks have been developed aiming at instrumenting testbed experimentation support.

Initially, Emulab and OMF (cOntrol Management Framework) were built focusing on the special requirements of the testbed type that were destined. Since their establishment, those frameworks have been evolved to accommodate to the realism of larger and more complex type of testbed experimentation including federation of geographically distributed testbeds. Each one has been designed to span and overlap over more heterogeneous technology deployments and offer diverse means of experimentation to end users. Even more, more specific tools and testbed experimentation frameworks have been developed to complement and over-provision certain services for different and various types of experimentation. Ofelia Control Framework, NEPI are such paradigms. Some of the basic and most common features that characterize their management operation are listed below in Table 2.

Table 2: Testbed Operational Features

Remote control and management
Publicly available remote access
Federation and shared resources capabilities
Systematic experiment definition
Flawless execution environment with transparent procedures
A systematic and contrived way of measurement collection
Experiment repeatability/reproducibility
Experiment verifiability

Moreover, contrary to wired network testbeds, wireless testbed deployments face very important challenges, that derive from the unpredicted behavior of the wireless connectivity which can affect seriously the experimental results. Therefore the management framework that controls and presides over the experimentation in this type of testbeds should incorporate means for assessing the wireless medium as well as to utilize efficiently the available resources. In this thesis we describe our approach towards the dissemination of wireless bandwidth on a non-RF isolated testbed using WiFi technology. Our contribu-

tion is composed of two basic subsystems that have been incorporated and utilized in the NITOS platform: *i*) An OSI layer 2 protocol that assesses Topology and Link Quality and *ii*) A scheduling service that performs fine-grained distribution of wireless bandwidth and prevents user experiments from interfering with each other.

1.1.2 Part II - Testbed Experimentation

Although the *Testbed Experimentation* part complements or follows logically after the first part of the *Testbed Development*, it can also be seen in a standalone fashion. In this second part we present topics and provide respective solutions inspired by the latest advances, trends and requirements in the field of wireless communications. Our initial motivation was the evaluation of the performance of the proposed techniques in a real system implementation so as to prove their validity and ensure their applicability. In this thesis we have proceeded in the implementation and evaluation of certain techniques and schemes that are pertinent to *scheduling and resource allocation schemes* in wireless networks. Considering the current challenges that contemporary networks face we have managed to provide consistent solutions relying on optimization theory techniques. Furthermore, as our intention was not limited by theory, we tested our solutions in real system implementation aiming to obtain tangible results. Below we describe the basic pilots that were the gist of our inspiration.

Are Contemporary Wireless Technologies Sufficient to Address Mobile Users Demands? Today we are witnessing an unprecedented growth on data traffic demand that puts significant strain to operators so as to provide sufficient solutions for satisfying mobile user demands. Taking also into account the mobiles users' increasing data consumption rate, there is a rational concern across industry and academia that networks are close to attain their capacity capabilities in the near future.

Current LTE rates support a peak download of 300 Mbps and 75 Mbps in the uplink under ideal conditions. Comparing those rates with the rates offered by former 3G and 3.5G technologies, they are about four to five times faster. LTE-A promises to offer higher rates, however, even those rates are insufficient to address the forecast for the increased data traffic demand [63] (see also Fig. 3 taken from Cisco Visual Networking Index Report).

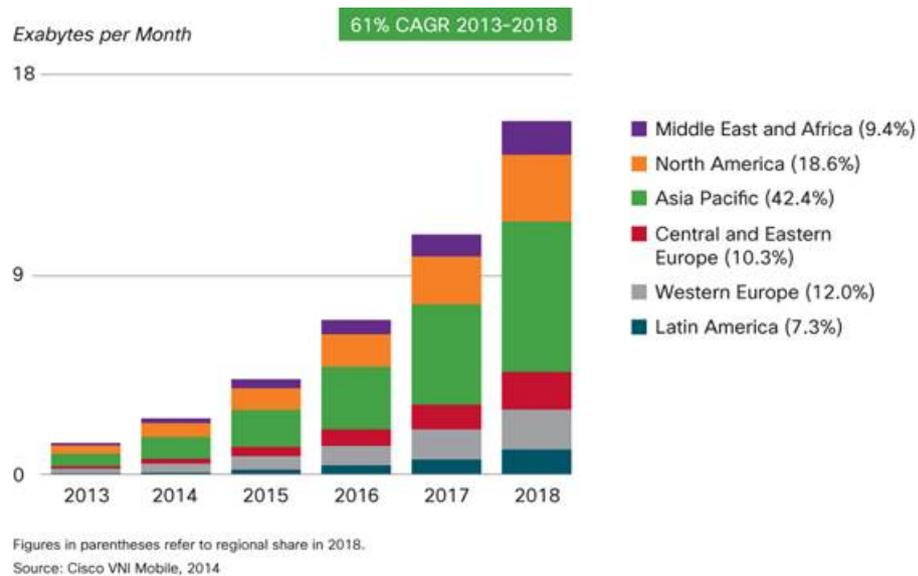

Figure 3: Cisco Mobile Data Traffic Forecast [63].

Even for WiFi technology things have considerably changed since its first introduction in the market in 1997. The first protocol promised to offer quoted downlink rates of 2Mbps, in sequence 802.11a and 802.11b enhanced WiFi versions promised to offer 11Mbps and 54Mbps, respectively. Since then many revised advancements have been unfolded and the latest 802.11ac version promises to deliver rates of at least 1Gbps and a single link throughput of at least 500 Mbps. Moreover, WiFi has become the wireless connection of choice (when it is available) for many mobile users, as most smartphones, tablets, laptops and mobile handheld devices are equipped with WiFi. In addition, novel WiFi advancements such as WiFi direct that allows the instant exchange of data between users, can act as enablers for proximity services between local users. With half of all IP traffic expected to be delivered over WiFi within 3 years [63], WiFi access points and network management software are increasingly important to mobile operators.

Alleviating the imminent capacity crunch is a challenge both for industry and academia. Of course their motivations stem from different origins (either pure fiscal or intellectual, or they can be a combination of the above), however, their targets lie on a common ground to deliver sophisticated solutions for guaranteed services to end users. In order to tackle the ever-increasing demand for data and to specify the requirements for future radio, wireless infrastructure companies and other members of the 3GPP standardization group, have set out an astounding challenge to increase capacity by “1000x by 2020” for the 5G standardization process. The key to the potential solution requires

a combination of many methods and techniques that are offered but not exploited at all by the current technology. Smart multiplexing of those methods can offer astounding tangible results. The above employs the management of more resources (power, capacity, frequency etc.) in the form of small cells and spectrum, as well as the adoption of radically different ways of acquiring, deploying, operating, scheduling and allocating these resources. Some of these methods incorporate techniques for cooperative networking, data relaying and forwarding, data offloading, small cell and Heterogeneous networks management and deployment.

Our aim in this thesis part is to study models that can be effectively leveraged in order to improve certain system performance targets as well as to provide tangible and practical solutions that can be incorporated into real system implementation. Moreover, we seek to attain balanced tradeoffs among optimization parameters and enable controllable knobs in order to provide flexible and robust solutions tackling the diverse ambient conditions of the wireless environment.

Relay and Cooperation: To Unfold the Hidden Potential of Wireless Communications: Cooperative relaying and data forwarding can unfold the wireless medium potential to offer boost in networking performance. Both throughput benefits and power consumption savings can be harvested just by rethinking the way that the contemporary communication operates. Consider the simplest scenario where a source node aims to transmit data to a destination node. If the communication link or wireless conditions between those two endpoints are insufficient to benefit the direct communication, then an alternative solution would be to leverage neighboring intermediate nodes to assist communication by forwarding the data. Despite the fact that the the above solution can be ostensible simplistic, it introduces novel ramifications that we seek to highlight comparing to the current wireless communication approach.

We identify solutions that can be both applicable to WiFi and LTE-A cellular networks. From the one hand, current cellular deployments cannot benefit users that are located in the cell edges and exhibit poor throughput performance causing also increased power consumption. From the other hand, WiFi wireless networks, either these are WLANS, mesh networks or rapid deployable networks utilizing WiFi direct technology, warrant for a new low-cost, ad-hoc, and viral approach that do not require traditional RF planning and can better leverage existing premises and backhaul opportunities.

Wireless Data Offloading: To Disrupt Contemporary Wireless Communications: WiFi offloading is emerging as an attractive solution to mobile network operators so as to mitigate the strain that they face to satisfy the mobile user increasing demand for traffic. As the number of mobile devices that feature WiFi capabilities is increasing and WiFi Access Points are becoming widely available in locations such as homes, offices, shopping malls, airports or stations, the offloading solution can play a pivotal role for becoming a shift paradigm in future networks.

Not only the need to provide sufficient services to mobile users, not only the total networking performance benefits, but also the interplay between operators and home users is essential to be ramified. Mobile network operators can lease already deployed WiFi networks to offload their traffic and reduce their servicing cost. In this context, determining which mobile users should be offloaded, based on the energy cost incurred to the cellular base stations (eNB) for serving their demands is of paramount importance. Accordingly, a routing policy that the mesh network should employ so as to serve the offloaded traffic with the minimum possible cost should be identified. Moreover, the reimbursement offered by the operator should be dispensed to the different mesh users, according to their contribution and added-value significance.

Mobile data offloading warrants for a viral deployment approach where heterogeneous cells and diverse technologies co-exist and overlap in the same location. A disruptive mobile data offloading framework is not limited to enable the toggling of users from cellular to WiFi, but it should coordinate *scheduling and resource allocation decisions* aiming to indicate efficient solutions for self organizing networks. Those decisions relying on the performance metrics and monetary reimbursement should enable consistent motivation to operators, mobile users and WiFi network users in order to participate in this interplay and benefit themselves.

1.2 SYNOPSIS

In this thesis, we initially present at the *first part* the efforts for creating an innovative wireless testbed facility to provide the means for efficient experimentation and instrumentation in wireless testbeds. Proceeding into the *second part* we explore through testbed experimentation *resource allocation and scheduling* problems. We study those problems, propose relative solutions and implement models in the context of cellular and ad-hoc wireless networks.

We begin with **Chapter 2**, where we propose a scheme that exploits wireless testbeds functionality by introducing spectrum slicing of the testbed resources. This scheme is incorporated inside OMF, an already existing wireless testbeds' managerial framework, which is widely used by many researchers. Our aim is to maximize the utilization efficiency of testbed resources among wireless testbeds users.

In **Chapter 3**, we focus on testbed resource management. We present a Topology and Link Quality Assessment Protocol (TLQAP), which we have implemented as a wireless testbed management framework component, that is used to inspect link quality between wireless testbed nodes and appropriately map them to user experiment requirements. TLQAP is used by experimenters to assess interconnection topology and link quality by estimating packet delivery ratio (PDR) and transmission delay at each node for all requested channel, rate and transmission power combinations. Moreover, we demonstrate TLQAP capabilities by developing a connectivity tool that utilizes TLQAP so as to visualize link quality assessment over the testbed topology.

Moving in the second part of this thesis, we deal with testbed experimentation. In **Chapter 4**, we present an implementation design of a TDMA protocol for the canonical diamond-topology network containing a source, two relays and a destination (single unicast session). We are getting inspired by the established Lyapunov-methodology, to propose an online strategy for the relay selection/scheduling problem. We implement this strategy inside the proposed TDMA protocol in order to operate over a CSMA enabled WiFi infrastructureless network. Our scheme has been implemented and tested thoroughly through experimentation in the NITOS wireless testbed.

In **Chapter 5**, we discuss the potential of leveraging relaying and data forwarding in next generation cellular networks. Getting inspired by the latest advances in the cellular networks, we discuss a potential evolution of LTE-A that employs user equipments (UE) as an active element of the network, in order to enable new use-cases. The proposed architecture leverages the legacy UE and extends its capabilities to operate simultaneously over multiple base stations (eNBs). Therefore, an evolved-UE (eUE) is introduced to enable reliable multi-hop operation through cooperative relaying and to achieve low latency communication through L2/MAC forwarding.

In **Chapter 6**, we study data offloading for LTE-A cellular mobile users to WiFi mesh networks. As the unprecedented growth of mobile data traffic places

significant strain on cellular networks, alternative plans for exploiting already existing and underutilized wireless infrastructure, become quite attractive. Mobile network operators can lease WiFi mesh networks to offload their traffic and reduce their servicing cost. We propose a framework to determine the power costly users which need to be offloaded, and a sharing profit framework that dispenses the financial merits among WiFi mesh users. We evaluate our work by simulating the operation of the LTE-A network, and conducting experimentation in the NITOS testbed for the mesh network.

Part I

TESTBED DEVELOPMENT

TOWARDS MAXIMIZING WIRELESS TESTBED UTILIZATION USING SPECTRUM SLICING

As experimentation becomes one of the de-facto approaches for benchmarking, researchers are turning to testbeds to test, review and verify their work. As a result, several research laboratories build wireless testbeds, in order to offer their researchers a real environment to test their algorithms. As testbeds become more and more popular, the need for a managerial tool that will not only provide a unified way for defining and executing an experiment and collecting experimental results, but that will also serve as many users as possible maximizing the utilization of its resources, is growing. In this spirit, we propose a scheme that exploits wireless testbeds functionality by introducing *spectrum slicing* of the testbed resources. This scheme can be incorporated inside OMF, an already existing wireless testbeds managerial framework, which is widely used by many researchers.

Keywords: wireless testbed experimentation, management framework, spectrum slicing

Related Published Work:

- C.[7] Angelos-Christos Anadiotis, Apostolos Apostolaras, Dimitris Syrivelis, Thanasis Korakis, Leandros Tassiulas, Luis Rodriguez, Ivan Seskar, and Maximilian Ott. "Towards maximizing wireless testbed utilization using spectrum slicing." In *Testbeds and Research Infrastructures. Development of Networks and Communities*, pages 299–314. Springer, 2011.
- C.[9] Angelos-Christos Anadiotis, Apostolos Apostolaras, Dimitris Syrivelis, Thanasis Korakis, Leandros Tassiulas, Luis Rodriguez, and Maximilian Ott. "A new slicing scheme for efficient use of wireless testbeds." In *Proceedings of the 4th ACM international workshop on Experimental evaluation and characterization*, pages 83–84. ACM, 2009.
- D.[2] Apostolos Apostolaras, Dimitris Syrivelis, Thanasis Korakis and Leandros Tassiulas "Achieving Efficient Resource Allocation on Non-RF Isolated Wireless Testbed Deployments."

- D.[5] Angelos-Christos Anadiotis, Apostolos Apostolaras, Dimitris Syrivelis, Thanasis Korakis, Leandros Tassioulas, Luis R Rodriguez, Ivan Seskar, and Maximilian Ott. "A demonstration of a slicing scheme for efficient use of testbed's resources." *Demo-Mobicom (September 2009)*, 2009.
- J.[1] Dimitris Giatsios, Apostolos Apostolaras, Thanasis Korakis, and Leandros Tassioulas. "Methodology and tools for measurements on wireless testbeds: The nitos approach." In *Measurement Methodology and Tools*, pages 61–80. Springer, 2013.
- J.[2] Giovanni Di Stasi, Roberto Bifulco, Stefano Avallone, Roberto Canonico, Apostolos Apostolaras, Nikolaos Giallelis, Thanasis Korakis, and Leandros Tassioulas. "Interconnection of geographically distributed wireless mesh testbeds: Resource sharing on a large scale." *Ad Hoc Networks*, 9(8):1389–1403, 2011.

2.1 INTRODUCTION

The theoretical analysis and the simulation of a new wireless protocol or technique can give us important information about its performance in terms of throughput, delay, power consumption, etc. However, in order to have analytically tractable models, several simplifications of the real world have to be made. While the simulations have the ability to incorporate more general models, we are still limited by the complexity of the simulation software and our limited knowledge of the wireless environment. Some specific limitations of the simulation approach in depicting a real wireless network include inaccurate representation of the wireless medium, simplification of synchronization issues that occur in wireless terminals and ignorance of several aspects such as the computational overhead.

Due to the above limitations, researchers have focused in the last few years on the studying of wireless schemes through implementing them on real platforms. Most of the implementation is done on open source platforms, such as software defined radios or open source wireless drivers. This new trend in wireless networks has triggered the birth and evolution of several wireless testbeds around the globe. Researchers may reserve a testbed for a specified time and execute their experiments there. But, how is that reservation made? Until now, the experimenter reserved the whole testbed (or a very large part of it if we are talking for a really big testbed such as ORBIT) even if he actually needed only

a few nodes and frequency channels. This reservation policy prohibits other users from using the testbed at the same time, since the experiments may interfere with each other. Moreover, most of the times the reservation is made after an oral agreement between the potential users.

An answer to these issues would be the dynamic, on-demand partition of the testbed to smaller parts, based on the available resources and the experimenters demands. So, we need to build a managerial mechanism that will be able to both handle multiple requests from the testbed users and partition the testbed efficiently by creating virtual slices and assigning them to the respective users. We intend to build such a mechanism using spectrum slicing techniques.

Currently, one of the most used testbeds is ORBIT [48] in WINLAB [20]. ORBIT consists of 400 nodes, available to the registered users. It has a very well organized management system which allows users to book the testbed at available time slots. Although ORBIT's reservation framework is very useful since it allows a large amount of users to remotely access the testbed, it has a significant drawback: It does not allow for efficient use of the testbed resources. In most of the experiments, only a small amount of nodes are being used, while the rest are staying idle. Usually, a researcher reserves the whole testbed (400 nodes) for a couple of hours and he only uses no more than 10 nodes, leaving the rest 390 nodes idle. With slicing, these nodes could serve the needs of other users.

ORBIT's example shows the need to develop a tool that will maximize the utility of a wireless testbed. In this work, we are proposing a scheme based on spectrum slicing, which takes advantage of the large availability of a particular resource -that is spectrum- and, through that, increases the whole testbed's availability to experimenters. Of course slicing can refer to other resources too, such as power (adjust the power that each slice will transmit to create a "safe" area for each user), network cards (a node that has many network cards could assign subgroups of them to different experimenters) and nodes (many users could use the same node using virtualization techniques), however in this work we focus on spectrum slicing. This scheme is developed as a part of a more generic managerial framework that is being designed in the concept of OneLab2 [15]. OneLab2 intends to federate heterogeneous testbeds located in different places under a unified system. As we are illustrating in later sections, our new managerial mechanism allocates a particular group of channels to a group of nodes that is assigned to one user. In this way, we opti-

mize the resources usage of the testbed by allowing multiple users to operate on the testbed simultaneously, without interfering with each other.

The challenge in wireless testbeds slicing is the isolation of experiments, as there are inter-dependencies among the resources. In contrast to a wired interface where all we need to do is to manage the sharing of a specified resource on a single node, sharing a wireless interface may also affect the sharing of interfaces on other nodes. What correlates them are things like spectrum, location and power which are also correlated. Power and location for instance, are two factors that could affect each other.

2.2 RELATED WORK

Several work has been made on efficient resource allocation on wireless testbeds. However, most of this work is focused on virtualization techniques, which implies more complex implementation and operating system dependence. Next, we are giving two representative examples of such systems:

emulab. Emulab is a network testbed, giving researchers a wide range of environments in which to develop, debug, and evaluate their systems. In Emulab, there has been developed a system which virtualizes hosts, routers and networks, while retaining near total application transparency. This system is based on FreeBSD Jails, which provides filesystem and network namespace isolation and some degree of superuser privilege restriction.[7]

mirage. Mirage is a resource allocation system, which was designed for sensor networks testbeds and it is based on an auction scheme. The experimenters are bidders, who argue for resources, using a virtual currency issued by the central system. So, if a user uses the testbed in a way that matches the system's criteria, then he has more credits to claim resources for a next experiment.[39]

nitlab. In NITLab [12], we have implemented a spectrum slicing scheme, which however had some significant drawbacks and we decided to change it to this one we are describing here. Specifically, we had focused on the new framework of Linux wireless drivers, provided by `cfg80211` [4]. Those two packets,

which are meant to replace Wireless Extensions [21, 108], can support Central Regulatory Domain Agent (CRDA) [6] which controls the channels to be set on the system, based on the regulations of each country. By making some changes on this, we managed to succeed spectrum slicing on our testbed. However, this scheme limited us in terms of the available drivers that could be used with it and the Linux kernel versions that could enhance CRDA. Moreover, this scheme's implementation was tricky and very much system dependable. [28, 29]

Our work here is independent from the related works described above and can be used in cooperation to them, as it schedules resource utilization from a higher level. Furthermore, we are moving our implementation on to a more abstract level, that is the one of the management framework, in order to set it platform independent, since OMF is intended to cover more platforms than just Linux. An analysis on virtualization schemes can be also found in [93], however in this work, we are actually implementing the spectrum slicing scheme, which as shown in Section 2.5 has a very good performance on our testbed, while with its extensions that we are planning (see Section 2.7), we are expecting to scale for even more large and complex testbeds.

2.3 WIRELESS TESTBED MANAGERIAL FRAMEWORK

We are using cOntrol and Management Framework (OMF) [95] for managerial framework. Currently OMF is deployed on several testbeds around the globe, including ORBIT. Using a ruby-like experiment definition language, the experimenter writes an abstract description of the experiment, stating which nodes to use and what for, uses traffic generators, sinkers and other utilities which are being constantly updated and integrated inside OMF. Providing full transparency to users, OMF is responsible for loading their images to the testbed nodes that they have asked for, for configuring the nodes based on the experiment description and for gathering the results. Currently OMF consists of three basic components: *Gridservices*, *Nodehandler* and *Nodeagent*, where the first two run on the testbed server, while the third one runs on each node. Next, we give a short description of each one of these components:

gridservices. Gridservices consist of a set of web services, which are responsible for both executing system actions, such as turning a node on or off,

rebooting nodes, loading images, etc. and getting information about the testbed as they have access to two databases: one for the testbed and its configuration and one for the scheduler where we keep information critical for slicing. Gridservices are residing on the testbed server.

nodehandler. Nodehandler does the actual testbed management using Gridservices and other operating system applications. The user interacts with the Nodehandler to load an image to the nodes and to execute an experiment. Based on the experiment definition, which Nodehandler is responsible to interpret, this component is sending the respective commands to the nodes in order to configure them and trigger the applications needed for the experiment. Like Gridservices, Nodehandler runs on the testbed server too.

nodeagent. Contrarily to Gridservices and Nodehandler, Nodeagent runs on the client-side of the testbed; that is the nodes. Previously we said that Nodehandler is responsible for sending commands to the nodes, based on the experiment definition. Here comes Nodeagent, which is responsible for receiving these commands them, understanding them and then trigger the respective applications. These applications could refer to the node configuration, a traffic generator, a traffic sink, etc.

We had to extend all the three components above to integrate spectrum slicing support inside OMF. In the next section, we will show our basic idea for achieving spectrum slicing, the dilemmas and the decisions we had to make when implementing our scheme in OMF.

2.4 SCHEDULING EXPERIMENTS ON WIRELESS TESTBEDS

Currently OMF does not include any scheduling algorithms that would synchronize the experiments execution. Its implementation does not include any permissions checking for access to the testbed resources. However, in a public, multiuser environment, we need a system that will be able to assign resources only to the users that have the right to use them, while offering the experimenters a way to declare the resources that they need for their experiments. In our work, resources are divided in two categories: *nodes* and *spectrum*. So, we are providing a tool which is used by the experimenters to reserve nodes and spectrum for some time (which should not exceed some limit). Using spec-

trum slicing, our tool makes the testbed available to users who would like to use different resources at the same time.

2.4.1 Spectrum Slicing

By slicing, we mean the partitioning of the testbed based on some criteria. With spectrum slicing, we aim to partition the testbed into smaller, virtual, testbeds which are using different spectrum and, hence, they do not interfere with each other. The spectrum that each virtual testbed will use could be either defined by the experimenter at scheduling or dynamically assigned, if the experimenter does not care about the channel that he uses (for example he could ask for any channel of 802.11g modulation).

Spectrum slicing can be combined with any other resource allocation scheme, since it does not require any “negotiations” with other system resources. Furthermore, spectrum is always associated with a wireless testbed experiment and, hence, there will always be a chance to slice the testbed based on the wireless channels each experiment needs.

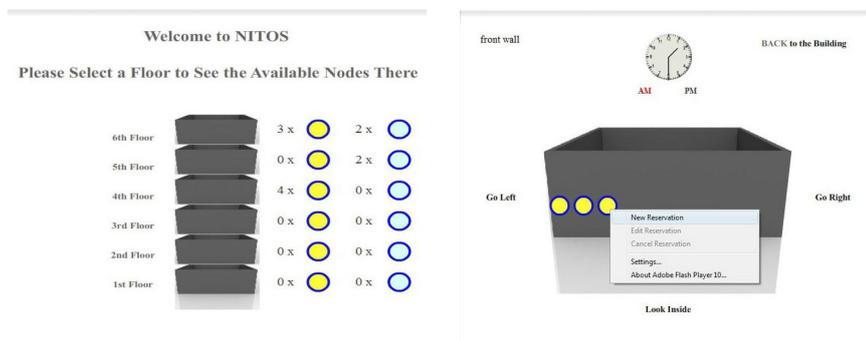

(a) Testbed deployment overview. (b) Selection of particular testbed node.

Figure 4: NITOS Scheduler Node Selection

2.4.2 Allocating Resources - Slices

Slices are created dynamically, upon the user reservation procedure. As we have already mentioned, we discriminate resources in two categories: nodes and spectrum. Resource allocation can be made statically or dynamically. Currently, we have developed a static scheme, but we working on extending it

based on Topology and Link Quality Assessment Protocol (TLQAP) [104]. In this scheme, the experimenter selects the nodes and the channels he would like to use during reservation, while at the same time, he also declares the time slots that he will be using those resources. Next, we are illustrating the basic idea of our resource allocation scheme, based on spectrum slicing. Finally, we are making a brief report on how dynamic resource allocation would be succeeded by extending our already existing tools.

Let us consider a testbed with OMF as its management system. As we have already mentioned, OMF does not include a scheduler, hence we need to develop one as a separate component of our system. In NITLab, we have developed a scheduler, whose User Interface is available to public, through our web site. This User Interface is responsible for guiding the user through the reservation process and is designed in such a manner that the experimenter may have a very specific view of the testbed topology. Providing outside and inside view of our six-floor building, we aim to give the experimenters the best perspective of the nodes that they are reserving for their experiments.

Now consider an experimenter who would like to use the testbed. Assuming that he has already registered, he may log in to the scheduler's web site and gain access to its User Interface. From there, he first chooses the date that he would like to run his experiments. Then, the actual scheduling process begins, with the experimenter seeing our testbed building with an indication beside each floor on the number of each node type that reside on that floor, as shown in Figure. 4.a.

Based on these data, the user can choose a floor and guide around it from both an outside and inside view. Having an exact view of the position of each node, he makes his choice by selecting to reserve one, as shown in Figure 4.b. But, we said that we allow many users to use the testbed at the same time, so how do we know that this user does not try to reserve a node, already reserved by another user? There is a clock on each frame, which can be clicked by the user on the time he would like to check the nodes status. By clicking there, the frame is automatically refreshed and the nodes are colored according to their status, while at the same time, the new user loses permission to request a new reservation on that node at that time. So, at this phase, the demand for reservation overlap prevention is satisfied; the experimenter chooses a node available at the time he needs it and proceeds to the next step.

At this point, the user has selected his node and he is about to reserve it for some time. For this end, we give him two clocks, one for choosing the start time for his experiment and one for the end time (see Figure 5a). But, hasn't he clicked on a clock before? If we give him another clock, how do we know that he won't try to use a node reserved by another user by "tricking" the scheduler? First of all, we need to clarify that the clock of the previous step is used for checking and not for reserving, as such a thing would not be very practical for the user. The answer of the second question that may arise is that we perform the same check of the previous step here too. So, when the time duration that the experimenter chooses at this step, includes time of another user on this node, the scheduler does not allow him to move on to the next step and, hence, reserve the node.

Guided by the scheduler, the experimenter has successfully chosen a node and some time to use it. The last thing he has to do is to choose the spectrum he would like to use; that is a group of channels that will be reserved for him during his time (see Figure 5b). Again, the scheduler does not allow the experimenter to choose a channel that is reserved by another one during that time. This is the final step; the experimenter submits his choice and the system reserves the node and the spectrum for him. After that, he goes to the first step, getting the picture of the whole building to continue with his reservations.

The scheduler identifies the user and lets him edit or delete his reservations at any time. It also keeps track of the last choices that he made on reservation time and spectrum, providing them to him as default choices for the current session. Finally, the scheduler provides the experimenter with the option to check out all his reservations, grouped by the reservation time. So, at any time, he may login and checkout the nodes and the channels he has reserved for some time.

2.4.3 *Implementation*

The implementation of our spectrum slicing scheme is done on two levels: (a) the user interface which guides the user through the reservation process and does not allow him to reserve an already reserved resource and (b) the OMF components, where we have added new and extended old ones to succeed the monitoring and control of the slices that are created at reservation. Next, we are examining in more depth the implementation details of each one of these two levels.

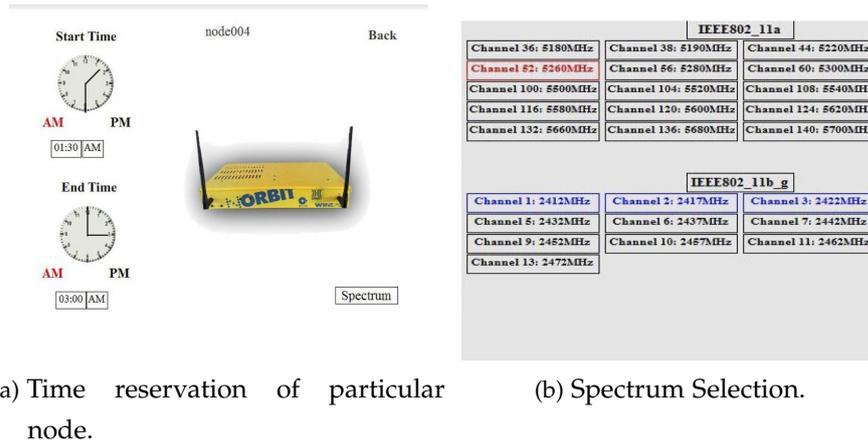

Figure 5: NITOS Scheduler Resource Reservation

2.4.3.1 User Interface

The scheduler's user interface is designed to be available through a web site, so that any users may have access to it. Its goal is to allow the experimenters reserve the resources they need (in terms of nodes and spectrum) in an efficient way for the testbed usage. So, we need to reassure two things: on the first hand an easy to use environment and, on the other hand, an application that does not allow their choices to mess with other experimenters ones. Next, we are giving the reservation procedure giving all the details of what happens underneath.

First the user has to log in and choose a date for his experiment. After that, we create session for that user where we hold the details of his account. From this point on, the scheduler knows who that user is and, based on that and the date, it manages permissions to resources that the user might need to access on the next steps. The main scheduling application is now deployed. This application consists of a flash animation which uses multiple PHP scripts and XML files to give the experimenter the information he needs, as we explain next.

The scheduler gives the user a perspective of the testbed topology. On our testbed, NITOS, which is located on a six floor building, the scheduler shows the number of each node type, residing on each floor. The topology view is loaded dynamically by using XML files. The scheduler application reads the respective configuration file and loads the topology that the experimenter will be able to use during his session. We have reached the choice of XML files because we are aiming to develop a tool that would easily support any other

similar wireless testbed, without having to do any major changes on the code. Moreover, the testbeds themselves are not static and it would not be convenient for the administrators to change the code each time a node falls down, or a new one is added to the testbed.

The user clicks on a floor and gets its perspective. Our user interface provides full inside and outside view of the floor. Along with this view, scheduler provides the user a clock where he clicks on the time he would like to check for reservations. Each click triggers a PHP script, which checks a database that resides on the testbed web server (for greater speed) and colors the nodes respectively. So, if the node is free at that time, it is colored with its native color and the user can make a new reservation. If the node is reserved by another user, it is colored red and the current user cannot do anything on it. Finally, if the node is reserved by this user, it is colored purple and the user can edit his reservation. What we actually do here is to grant permissions on each node (resource) based on the user that claims it.

The next step, is using similar tools with the experimenter clicking on start and end time for his experiment and the scheduler checking if those are available. At each step, the scheduler does not allow the user to move on without making a right choice. When this step has finished, the experimenter has selected a node and a time duration for his experiment.

Moving on to the final step, the experimenter has to declare the set of channels that he needs to perform his experiments. Again, using an XML file, scheduler loads all channels available, based on the laws of each country. After that, it checks the database to see which of these channels are reserved by other users and which ones are reserved by this user at a previous step. Keeping the same template as before, we mark with red the frequencies that cannot be chosen, with purple the user's previous choices on this node (in case the user had selected to edit his reservation) and with blue the previous user's choices on this session, so that he does not have to select the same channels again and again for each node he reserves.

After that step, the user's choices are committed to the scheduler's database. This database contains information about the testbed topology, the available spectrum and, of course, all users reservations. Using PHP scripts and XML configuration files, this database can be automatically updated through the web site by the scheduler's administrators. Furthermore, the scheduler's web site can provide information to each user of the reservations he has made until

now, so that he may see older preferences which fitted, check the exact reservation details when the time has come to execute the experiment, or anything else.

Finally, since the scheduler's user interface resides on the web server, while the testbed has another server, we have setup a secure communication channel, which is used by the scheduler to inform the testbed server's cron daemon to schedule necessary tasks for each experiment. Such tasks are unlocking the users accounts when the reservation starts and locking them when it ends and setting up firewall rules that prevent the users from trying to access nodes that are not assigned to them, by using applications others than OMF (for example secure shell).

2.4.3.2 *OMF Components*

Until now we have described the part of the scheduler which is focused to the experimenter and his choices at reservation. This, however, is not always enough. Mistakes can be made some times willingly, some times not; in any case, we need to ensure that the experimenters will stick on their choices and, even if they try, the system will not allow them to use any resources that they have not reserved.

In order to do that, we have chosen to extend OMF, which is a very popular managerial framework for wireless testbeds. In Section 2.3, we gave a short description on OMF, how it is structured and the role of its components. Here, we give a detailed description of the additions and the extensions we had to make inside this framework to integrate spectrum slicing support in it.

Before anything else, we need a way for OMF and the scheduler's database to communicate. For this purpose, we have added one more service group to Gridservices named scheduler and we have added one more service to the inventory service group. Now, let's see what these services are responsible for. First of all, the inventory service group is developed inside OMF and provides a set of webservice that provide general information about the testbed (such as node names, IP addresses, etc). This information is stored in a database residing on the testbed server and the inventory service group reads this database to return the proper response. Our addition here is a service which gets a node location (that is its coordinates) based on its IP address. Note here that the node location is a piece of information that is the same on both the scheduler's

and the testbed's database and, thus, we can use it to do the matching. We have added this service, because when an experiment is executed, OMF does not know a node's location; only its IP address.

Now that scheduler knows the exact location of the node, it can use the scheduler service group to get any information needed from the scheduler's database. Namely, the services provided by this group provide functionality to get a node reservations based on its coordinates, the spectrum that this reservation contains and the user that owns it. Furthermore, it provides services that can do the matching between a channel or a frequency number and the respective spectrum identification number as it is stored in the database. All this information will be used by Nodeagent, which decides whether to allow the user use the channel or not.

So, Nodeagent is responsible for deciding whether the resources declared in the experiment should be allocated to the experimenter. In order to decide, the Nodeagent has to ask the scheduler's database if the specified resources have been reserved by the experimenter. But when is the proper time to do that? Nodeagent will wait until the time comes for the wireless network card configuration on the node. At that time, the experiment defines a channel to be used by the network card. So, at this point, Nodeagent knows the channel and its own IP address. All he needs is the user identification to check with the scheduler's database if this channel (and, of course, node) should be allocated to that user.

However, this is not straightforward, since the user usually logs into the node as root (keep in mind that the experiment loads his own image to the nodes, so he has full privileges on them). So, we need to track where did he use the username that he also used for registering. The scheduler is designed in such a manner that, when a user registers to the system, then an account with the same username and password is automatically created to the testbed's server. The user uses this account to both access the user interface and the testbed server (using secure shell connection). Now this can solve our problem, since we can say for sure that the user that is running the experiment is logged into the console with the same username that he has made his reservation.

This information, though, relies on the testbed server, while the Nodeagent runs on the client side; that is the nodes. We need to pass that information from the server to the clients. This is done by the Nodehandler, the OMF service that is running on the server side and is responsible for controlling the experiment

execution. Using its built-in message passing mechanism, Nodehandler tells the Nodeagent the username of the experimenter and now the last one has almost everything he needs to do the matching. Anything, but the date: the system should not rely on the experimenter to keep the clock of his clients coordinated with the testbed. This is why, Nodehandler sends, along with the username, the date at that time and the Nodeagent adjusts its clock to match the server's.

At this point, Nodeagent has all the information needed to check with the scheduler if the requested resources should be allocated to the experimenter. Using the web services we described above, the Nodeagent checks if there is a reservation at that time for that user and if the spectrum reserved at this reservation matches the channel that the experimenter has requested to assign to the network card through his experiment.

If all data match, then the Nodeagent lets the experiment execution move on. Otherwise, it notifies the Nodehandler that a resource violation has taken place and stops its execution (without assigning the channel to the node's network card). When the Nodehandler receives that message, the execution is terminated immediately and an ERROR message is thrown back to the experimenter describing the resource violation.

2.5 SLICING IN ACTION - USAGE STATISTICS

2.5.1 *Testbed Description*

The testbed that we used for design and deployment of our scheme is consisted of 10 ORBIT-like nodes, as depicted in Figure 10b and 5 Diskless nodes, as shown in Figure 6b. An ORBIT-line node consists of a 1GHz VIA C3 processor, 512MB of RAM, 40GB of hard disk, two ethernet ports and two miniPCI slots which are used to host two Atheros WiFi cards. Our diskless nodes consist of a 500 MHz AMD Geode LX800 CPU, 256MB of RAM, a 1GB Flash Memory Card, two ethernet LAN ports and two Atheros wireless cards.

All the nodes are connected through wired Ethernet with the testbed's server - *console*. In console we have all the required testbed services running. These services are both network services, such as Dynamic Host Configuration Protocol (DHCP) server which gives IP address to the nodes, Domain Name Sys-

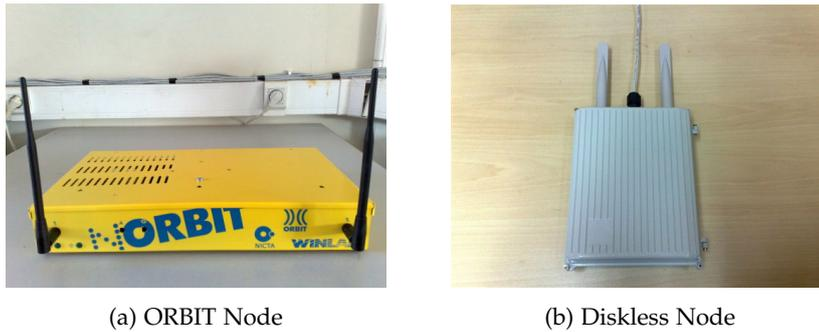

Figure 6: NITOS Nodes

tem (DNS) server which gives names to the nodes, Network File System (NFS) server for experiment results and slicing support as we are going to see next, and testbed services which are combined to the functionality of OMF.

We also maintain a web server where we keep the web interface of our system's scheduler. On this server, we also keep some scripts mandatory for remotely booking the nodes and a MySQL server for keeping records of the testbed status at each slot. Finally, we have set up a secure communication line, using Secure Shell (SSH) and a RSA key between the web server and console so that the scripts on the web server trigger the respective scripts on console.

After the user books some nodes at a specific time on the testbed, he logs into console at that time and from there, he can start using the testbed. The image is loaded on each node from console through the wired Ethernet interface. More information about our testbed's architecture can be found at our web site.

Although we have built this scheme on our testbed, it could also be applied to any wireless testbed which is using OMF as its management framework.

2.5.2 Usage Statistics

To outline slicing benefits, we have monitored testbed usage for a period of 5 months. We have added logging support to our scheduler as follows: The user is firstly prompted to enter the number of nodes that are needed by his/her experiment without being able to see which testbed nodes are occupied. If the system has enough resources to satisfy the request, the user may continue with the standard allocation procedure. Otherwise, the scheduler informs the user that the required amount of nodes cannot be allocated. With this approach we were able to log the allocation requests which were denied. Note that in the

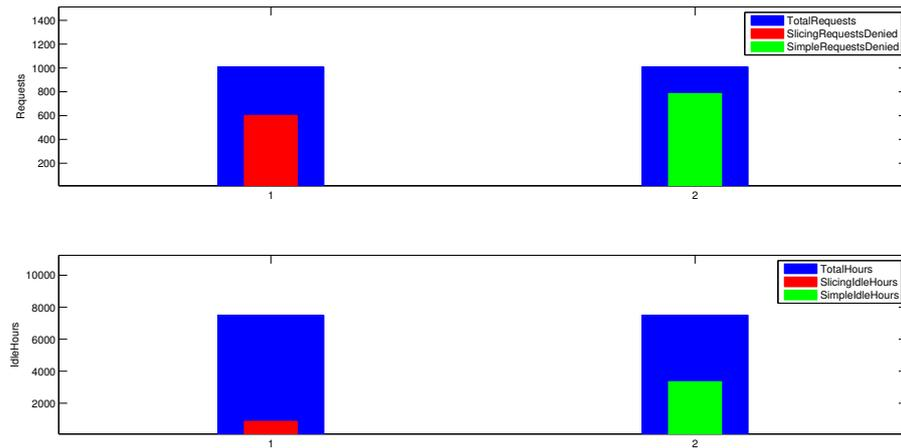

Figure 7: Slicing performance for a 5-month period, compared to the simple allocation policy simulator results for exactly the same workload.

standard scheduler interface, the user is provided with enough visual information to determine whether the required number of nodes is available or not and avoids issuing requests which would be denied.

During these 5 months, the testbed use was approximately 500 hours. During these hours a total of 1008 requests were issued. To determine overall testbed utilization, we logged for each hour during which the testbed was in use and allocation requests were denied, the number of nodes that were not occupied. More specifically, we regard as the testbed idle time unit the idle hour of a single node. If for example 5 nodes are idle during a testbed usage hour this amounts to 5 idle hours. Since we have 15 nodes, the available usage time units of the logging period were 7500 ($\text{TestbedUsageHours} * \text{NumberOfNodes}$). To compare slicing with the simple allocation scheme that cannot allocate wireless frequencies, we developed a simulator. We should note here, that our testbed topology, in terms of physical wireless range, forms 2 independent neighbourhoods. The first neighbourhood has 7 nodes and the second 8. Therefore, the simple node allocation scheme can assign each node neighbourhood independently and host up to two testbed users concurrently. Our simulator implements this policy, replays the allocation requests that have been logged for the 5-month period, determines the number of denied requests and testbed utilization time of the simple allocation scheme. In figure 7 we depict the number of denied requests along with the testbed total idle time that we logged for slicing and simulated for simple allocation scheme.

2.6 CONCLUSIONS

As wireless networking research emerges, the respective testbed infrastructures and management systems should employ more sophisticated approaches to distribute available resources. While many of the management concepts that have been introduced for wired testbeds, have been extended and reused by wireless testbed management frameworks, the latter face an additional important challenge: the distribution and management of the wireless bandwidth in terms of frequency channels, which along with the node topology and connectivity range can become a very complicated task. In this work we attempted to address this issues.

Managing and distributing a collection of wire interconnected computers to multiple users with guaranteed resource availability, like the number of dedicated processors, memory and network bandwidth, has a number of challenges which have already been addressed by wired media managing frameworks. To deploy an experiment, the wireless testbed user will need to allocate nodes that satisfy certain topology and link quality requirements. Moreover, the knowledge of the maximum possible throughput that each connection can achieve, allows the user to properly evaluate the observed experiment performance. In some wireless testbed deployments [20] where all the nodes are in an RF isolated room and are tightly located to avoid connectivity range problems, the allocation of frequency channel, also known as slicing, can be performed in a static manner. In these setups, wireless channels and bandwidth can be distributed as any other resource, like processors or memory and the user must not be able to change them.

While the described wireless testbed deployments are appropriate for a wide range of networking system experiments, there is also a need for testbed deployments that are closer to an end user setup. In such deployments there might be indoor and outdoor nodes with wireless links of varying quality, where some of them might not be able to directly communicate. Moreover, the testbed might not be RF isolated, e.g. deployed on a campus site, where several other wireless terminals, out of the testbed context, compete for channel use. Nevertheless, for a certain range of experiments, that usually belong in wireless mesh network research, the user can take advantage of the described testbed setups to evaluate networking systems (e.g. adhoc routing protocols, hidden terminal solutions).

Regarding resource reservation, until now, the user reserved the whole testbed (or a very large part of it if we are talking for a really big testbed such as ORBIT) even if he actually needed only a few nodes and frequency channels. This reservation policy prohibits other users from using the testbed at the same time, since the experiments may interfere with each other. An answer to these issues would be the dynamic, on-demand partition of the testbed to smaller parts, based on the available resources and the user demands. To address these issues we have build a mechanism that uses spectrum slicing techniques but, still, not all allocation problems have been solved. The user does not apriori know which nodes will satisfy the experiment needs. Most experiments will require certain topologies and link qualities between the nodes. A complete system will interact with the user, gather experiment requirements, find the nodes that satisfy them and proceed with the slicing allocation. In this work we have merged our scheduler with Topology and Link Quality Assessment Protocol (TLQAP) that is described in [104] to provide this support.

The proposed allocation scheme has been developed as a part of a more generic managerial framework that is being designed in the concept of OneLab2 [15]. OneLab2 intends to federate heterogeneous testbeds located in different places under a unified system.

2.7 FUTURE WORK

In the domain of scheduling experiments on wireless testbeds, there still is much work that has to be done. Since we are expecting a growth to the testbeds usage by the researchers in the near future, we should put our efforts in developing a scheduling scheme, which will be able to allocate resources to experimenters efficiently, while, in the same time, it will be providing a transparent mechanism for executing the experiments.

First of all, we are working on integrating TLQAP in our scheduler. The scheduler can use TLQAP to extract information about the status of the testbed resources at any time needed. With this information, it is in place to match the experimenters demands on power, spectrum, location, etc. with the resources and schedule the experiment whenever they are available, without having the experimenter himself to check for their availability at each slot.

As a next step, we are designing a smarter scheduler, which will be working in a mode similar to an operating system's one. In detail, we are planning

to create a tool, with which, the scheduler will be able to handle multiple experimenters and allocate resources dynamically to users. With this scheme, we may have two users, running their experiments simultaneously, using channel 8, with the scheduler letting the first user to transmit for some time and then the other (just like sharing a resource to many processes on a personal computer).

Furthermore, we are working on implementing other slicing schemes, which will depend on the transmission power control, the sharing of wireless network cards and the sharing of nodes themselves. For instance, we may adjust the power that a node will transmit based on the experiment characteristics and, thus, create a smaller neighborhood where the experiment will take place, while the rest of the testbed will stay available to other users. With network cards sharing, we plan to let two users make use of a node which has two wireless cards on, by assigning one card to each user. Finally, nodes sharing will give us the power to run multiple experiments on different images on the same for multiple users. We are expecting that this last scheme, in combination with spectrum and power slicing and wireless cards sharing, will give us a large scale improvement to the testbed utilization.

Wireless testbeds federation is another step that we are planning to take. The additions made for spectrum slicing in OMF services, provide us a very good tool for this end. We are thinking federation in two aspects: that of experiment execution and of experiment scheduling. Our work focuses on satisfying both these aspects using web services, which can be used as the tool to remotely invoke resource, get information, etc. However, with federation, we have other issues arising too, such as security, since we are dealing with resource allocation through a public network (Internet).

Our efforts are focused in developing a framework that will give the end-user a transparent solution for experiments execution, while at the same time, on the inside, it will use sophisticated mechanisms for efficient resource allocation and experiment execution. We believe that this work and our future plans are the right steps to this direction.

TLQAP: A TOPOLOGY AND LINK QUALITY ASSESSMENT PROTOCOL FOR EFFICIENT NODE ALLOCATION ON WIRELESS TESTBEDS

In this chapter we present Topology and Link Quality Assessment Protocol (*TLQAP*), which we have implemented as a wireless testbed management framework component, that is used to inspect link quality between wireless testbed nodes and appropriately map them to user experiment requirements. *TLQAP* is mainly an OSI layer 2 design for fixed location, non RF-isolated wireless testbed deployments, which assesses interconnection topology and link quality by estimating packet delivery ratio (PDR) and transmission delay at each node for all requested channel, rate and transmission power combinations. Moreover, *TLQAP* builds a measurement history log and creates a channel utilization profile, in the context of each testbed node, for all the nearby testbed-external devices that operate independently in the region and are not under the management framework control. The analysis of this information enables *TLQAP* to choose the channels that have the highest probability of being free during an experiment. *TLQAP* OSI layer 2 component has been implemented in the click modular router framework and the controller component has been integrated with *OMF* management framework for wireless testbeds. To outline *TLQAP* benefits, we have performed experiments on our ORBIT node testbed and we compare it to an existing application level measuring tool.

Keywords: link quality measurements, wireless testbed management framework

Related Published Work:

- C.[10] Dimitris Syrivelis, Angelos-Christos Anadiotis, Apostolos Apostolaras, Thanasis Korakis, and Leandros Tassioulas. “*Tlqap: A topology and link quality assessment protocol for efficient node allocation on wireless testbeds.*” In *Proceedings of the 4th ACM international workshop on Experimental evaluation and characterization*, pages 27–34. ACM, 2009.

- D.[2] Apostolos Apostolaras, Dimitris Syrivelis, Thanasis Korakis and Leandros Tassioulas “Achieving Efficient Resource Allocation on Non-RF Isolated Wireless Testbed Deployments.” *In the proceedings of Future Network and Mobile Summit 2010, Florence, Italy, June 2010.*
- D.[3] Apostolos Apostolaras, Vasileios Miliotis, Nikos Giallelis, Dimitris Syrivelis, Thanasis Korakis and Leandros Tassioulas, “A Demonstration of a Management Tool for Assessing Channel Quality Information in Wireless Testbeds.”, *In the proceedings Tridentcom 2010, Berlin, Germany, May 2010.*

3.1 INTRODUCTION

As wireless computer networking is becoming mainstream for almost any type of network deployments, research at all design levels of wireless systems is very active. While for wired network solutions most researchers developed prototypes on simulation environments, the unpredictable factors that can affect the quality of wireless connectivity, especially in large-scale experiments, made respective wireless systems simulations almost impossible. To that end, there is a great need to deploy and manage wireless testbeds that can be used for the development and evaluation of wireless networking systems.

Managing and distributing a collection of wire interconnected computers to multiple users with guaranteed resource availability, like the number of dedicated processors, memory and network bandwidth, has a number of challenges which have already been addressed by managing frameworks for High Performance Computing (HPC) clusters. In the same spirit, wireless testbed deployments also feature a wired ethernet backbone that is used by the respective resource management frameworks [95]. Therefore, many of the management concepts that have been introduced for wired testbeds[7][18], have been extended and reused by wireless testbed management frameworks. On the other hand, the latter face an additional important challenge: the distribution and management of the wireless bandwidth in terms of frequency channels, which along with the node topology and connectivity range can become a very complicated task.

To deploy an experiment, the wireless testbed user will need to allocate nodes that satisfy certain topology and link quality requirements. Moreover, the knowledge of the maximum possible throughput that each connection can achieve, allows the user to properly evaluate the observed experiment perfor-

mance. In some wireless testbed deployments [20] where all the nodes are in an RF isolated room and are tightly located to avoid connectivity range problems, the allocation of frequency channel, also known as slicing [25], can be performed in a static manner. In these setups, wireless channels and bandwidth can be distributed as any other resource, like processors or memory and the user must not be able to change them. An approach on how this can be achieved is described in [25].

While the described wireless testbed deployments are appropriate for a wide range of networking system experiments, there is also a need for testbed deployments that are closer to an end user setup. In such deployments there might be indoor and outdoor nodes with wireless links of varying quality, where some of them might not be able to directly communicate. Moreover, the testbed might not be RF isolated, e.g. deployed on a campus site [40] [38], where several other wireless terminals, out of the testbed context, compete for channel use. Nevertheless, for a certain range of experiments, that usually belong in wireless mesh network research, the user can take advantage of the described testbed setups to evaluate networking systems (e.g. adhoc routing protocols, hidden terminal solutions). In these testbed cases, the user will need to know the actual link quality of all the wireless links, as well as the possible topologies that can be formed by the allocated nodes, in order to evaluate the experimental results. For example let's assume that a user needs to test a network coding design approach.

In network coding, each node that acts as a gateway between other nodes that cannot communicate directly, may produce a linear combination (mix) of two or more packets that belong to different flows and avoid this way explicit transmissions by performing a single transmission of the mixed packet (which must be appropriately decoded at each destination). Obviously, the biggest challenge of network coding schemes is to properly identify coding opportunities which directly depend on the network topology and link quality. In this case the user needs to allocate nodes that satisfy certain topology requirements and needs to know explicitly the location of each node on the connectivity graph. In such cases the testbed management framework needs a system like *TLQAP* to satisfy the node allocation requirement.

Of course, since the testbed deployment is not RF isolated and the environment is volatile, the link quality between any pair of nodes may unexpectedly vary at any point in time due to external interference. For this reason the static

distribution approach, that is used in RF isolated wireless testbeds, is not efficient for these deployments.

The wireless management framework of non RF isolated testbeds should feature support that can quickly and accurately inspect the current link qualities between all the available testbed nodes and at all available channels. This should be the first step of the management framework response to a node allocation demand. Frequent inspection of the link quality will enable the framework to allocate the nodes that at least have the highest probability to satisfy the experiment requirements. Of course, during the actual experiment deployment, intrusive external interference may appear but this will happen with reduced probability compared to a static channel allocation method. Moreover, the management framework may perform inspections whenever the testbed is not in use and identify, independently for each link, time periods where external interference will be with high probability minimal. The main characteristics of an inspection subsystem that frequently determines the quality of wireless links between testbed nodes should be accuracy, speed and scalability.

In this work we propose the Topology and Link Quality Assessment Protocol (*TLQAP*) which has been designed to satisfy efficiently the aforementioned need for node allocation on non RF isolated wireless testbeds. *TLQAP* is an OSI Layer 2 protocol, tightly integrated with the underlying MAC layer that exports a control and configuration interface which can be used appropriately by a management framework. The latter may use *TLQAP* support to quickly and accurately determine the current quality of the wireless links between testbed nodes, on all available channels and rates. We have implemented *TLQAP* in the click modular router [73] taking advantage of the available click extensions for the madwifi driver [11]. On the control side we have implemented an OMF based controller plugin, that interacts with *TLQAP*, observes link qualities and allocates the appropriate nodes based on the user experiment demands. In the sections that follow we describe the *TLQAP* protocol, all system components and their organization and we compare the accuracy, the speed and the scalability of our approach with an approach that is based on existing tools.

3.2 TLQAP PROTOCOL

The *TLQAP* approach is based on actual throughput measurements of a fixed number of consecutive packet transmissions that are initiated at each testbed node. A typical *TLQAP* session is as follows. The management framework in-

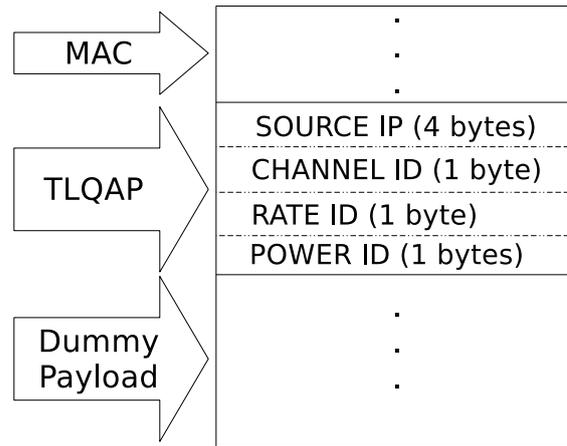
Figure 8: *TLQAP* header.

interacts with the user and creates an xml file (presented in the implementation section) that describes the required link quality between the nodes that form the network topology. Then the framework generates a list of the available nodes and channels, that are not currently assigned to other experiments, and deploys the *TLQAP* system. After all the nodes are ready, the management framework sequentially starts for each node, channel rate and transmission power, the *TLQAP* transmission sessions.

Each *TLQAP* session is comprised of a user defined number of fixed size packets which are transmitted in one burst at a specific channel, rate and power combination. These packets are addressed to an arbitrary neighbor node of the current transmitter and must be transmitted without the 802.11 support for low level acknowledgements and retransmissions. Otherwise, the packet loss ratio as captured by *TLQAP* will be far lower than the underlying, actual loss ratio. Only one *TLQAP* session is testbed wide allowed at a time, so the next *TLQAP* session on any node may begin after the previous one is completely finished and all the scheduled packets have been transmitted. Each node initiates *TLQAP* transmission sessions for all the required channel, rate and power combinations.

On the other hand, each node sniffs (media is in monitor mode) and logs all the *TLQAP* packets that it can hear. *TLQAP* features a network packet header that is placed immediately after the ethernet header as depicted in Fig. 8. The header fields are the sender IP address along with globally agreed identification numbers for the channel, rate and transmission power that have been used for current packet transmission. The *TLQAP* log is based on a counter map that holds an independent counter for each sender IP, channel, rate and

power combination. Each counter is incremented when a packet with the appropriate combination arrives. After all *TLQAP* sessions have completed, the management framework collects the counter maps from all the nodes and processes them to calculate, for each node, the packet delivery ratio (PDR) for each channel, rate and power. The PDR from node X to each node Y is calculated by dividing the number of packets received by Y by the number sent by X . As we have mentioned, during each transmission session a fixed number of packets is transmitted. The respective session transmission delay is recorded and it is immediately retrieved by the management framework which, along with the counter maps, has all the information that are needed to: i) calculate PDR for each available link direction and ii) inspect channel traffic. In the next section we give more details on how we perform all the measurements.

3.3 SYSTEM IMPLEMENTATION

The *TLQAP* implementation features two main components: An OSI layer 2 component that has been integrated with the linux network stack and a controller component that has been implemented as an OMF [95] wireless management framework extension.

3.3.1 Network Stack Support

We have implemented the *TLQAP* protocol in the click modular router framework [73]. Click is a linux packet processor engine that has been integrated in the linux network stack and is suitable for the development of real world, production quality, networking systems that are primarily targetted at OSI layer 2 and 3. In the *TLQAP* implementation we have used the click extensions for the madwifi driver that controls the Atheros 5212 chipset. With these extensions, *TLQAP* can configure the underlying driver parameters like transmission rate and power independently for each packet.

The click *TLQAP* implementation is comprised of two so called click elements: The *TLQAP* receiver and the *TLQAP* transmitter. The network stack incoming and outgoing processing paths are depicted in figure 9 a) and Fig. 9 b) respectively.

Empty packets of a fixed size are generated by the click *RatedSource* element that along with a *Burster* element form the packet generator engine. This pro-

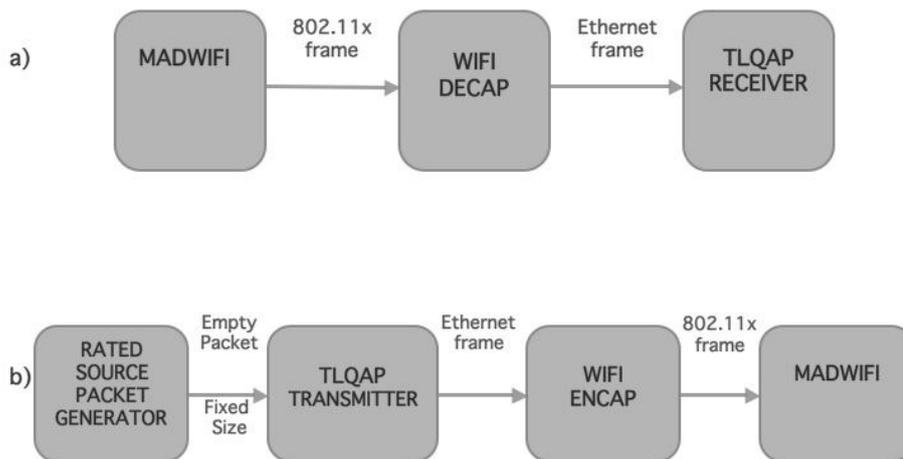

Figure 9: *TLQAP* in the Network Stack: a) incoming path, b) outgoing path

duces a fixed number of packets for each transmission session and pushes them all at once to the next element which is the *TLQAPtransmitter*. This element, based on its current configuration (rate, channel, power), encapsulates the packets that arrive from the generator with a properly informed *TLQAP* header (Fig. 8) and enqueues them to its transmission queue.

The underlying madwifi driver is instructed to transmit addressed packets without 802.11x level acknowledgements and retransmissions but it does use the transmission slot backoff policy. This way the transmission delay of a session packet set depends entirely on the rate and the channel traffic. Transmission delay for a broadcast session is accurately recorded by the *TLQAPtransmitter* and the value is immediately retrieved by the OMF management framework, which has to wait for the transmission session to finish. The recorded delay is used to determine possible channel traffic that originates from a testbed external source. This is a straight forward estimation because at a specific rate Y bytes/sec, a fixed number X of fixed sized packets of byte size Z , needs $W * \frac{XZ}{Y}$ seconds to get transmitted over a free channel. The factor W is used because the wifi header bytes are stripped before delivery to *TLQAPreceiver* without being counted, while other low level 802.11 details may introduce additional byte transfer delay. After performing numerous experiments on free channels and different rates we have seen that for 1400 byte ethernet frames W is equal to 0.7. If the channel is not free, the low level 802.11 transmission back-off delays will increase the overall packet transmission delay. The fraction of the recorded *TLQAPtransmitter* delay by the theoretical transmission delay of a

session packet set gives the respective free channel ratio. Obviously the larger the packet set, the more accurate the free channel ratio estimation because a larger time slot is inspected.

Notably, since *TLQAP* sessions are transmitted in a single burst and immediately saturate the MAC layer at all available transmission rates, the channel utilization can be again estimated during each transmission session and an average can be returned by *TLQAP* system for each channel. This approach is employed to inspect channel utilization for a larger time slot which improves the traffic observation. For this reason, *TLQAP* sessions, which are started from the highest provided rate, do not stop when PDR is found equal to one at all recipient nodes. Note that, in this case, PDR for lower rates will be definitely equal to 1 for all nodes and the broadcasts from that point onwards are performed only to inspect channel utilization. Of course, the fact that a channel is found free during the *TLQAP* measurements does not provide any form of guarantee that it will continue to be available during the actual deployment of the user experiment. In the next subsection we describe framework support that increases the probability that a channel will continue to be free during the actual testbed use.

In the incoming path (Fig. 9 a), the madwifi driver is configured to operate in monitor mode and delivers for processing all the frames it receives. After the wifi header decapsulation the packet is delivered to the *TLQAPreceiver* element, which checks if it contains a *TLQAP* header. If it does, the element reads all the *TLQAP* field values and forms a hash identifier that is used to retrieve and increment the appropriate counter from a hash table (counter map). The received packet is then discarded. The counter map contents can be retrieved at any time from the management framework.

Both *TLQAPtransmitter* and *TLQAPreceiver* elements can be configured via the click communication interface. The latter can be accessed on each node via telnet (over the wired ethernet) or locally via loopback interface. This communication channel is also used for data retrievals. The described support allows easy integration of *TLQAP* with any type of management framework.

3.3.2 Management Framework Support

We have integrated *TLQAP* with the OMF framework for wireless testbeds. *OMF* is a Control, Management and Measurement Framework that provides

the users with a set of tools to describe, execute and collect the results of an experiment in a straight forward manner. There are three main components that comprise OMF: i) the gridservices, ii) the nodehandler and iii) the nodeagent. Below, we give a short description for each one of these components.

Gridservices is a set of web services that are used by *OMF* to fetch information and perform actions remotely on the nodes. These services can be used for the node system image loading, the experiment execution and the results collection.

Nodehandler resides on the central server that interacts with the user for the experiment submission. Moreover, it provides the necessary applications for node system image loading, experiment execution, image saving and node status check. Nodehandler communicates with both the gridservices and the nodeagent to get the required information and perform actions. Regarding the experiment deployment, nodehandler contains a set of prototypes that can be used for experiment definition. Based on a message passing system, the nodehandler uses either multicast or unicast communication to contact nodeagent(s) in order to initiate and control experiment deployment. Finally, nodehandler watches the experiment execution and notifies the user for any problems that may arise.

A nodeagent instance is deployed on each testbed node. Contrary to the nodehandler which is triggered upon load, execution, save or status call, the nodeagent is constantly active. It is waiting for information to arrive from the nodehandler, which contain instructions for the experiment deployment. Since nodeagent runs as a background process, it reports its state to the nodehandler, which in turn notifies the user.

Apart from these existing components, *OMF* is being currently extended with a new component that performs scheduling. In this first scheduler version, the user may request the topology and the resources needed for his experiments. Obviously, the scheduler needs to determine the current testbed topology, link quality and channel utilization to properly decide which node set matches the experiment requirements.

More specifically, we developed an *OMF* based *TLQAP* controller component to accomplish the following tasks: i) interact with our scheduler and get a list with nodes and spectrum availability as well as topology and link quality requirements, ii) configure *TLQAPtransmitter* and start transmission sessions

sequentially on each node, iii) collect the transmission delay for each broadcast session after it is completed, iv) collect the counter maps from all nodes, v) process results, allocate the nodes and reply to the scheduler.

Initially the user should provide the framework with an abstract description of the nodes and the link characteristics that are needed between them. Based on those data, the scheduler creates an XML description of the users' request. Before starting the XML dialog, the scheduler also collects information about the available nodes and the spectrum. Then it initiates communication with the *TLQAP* controller, that runs on the OMF server and provides the available nodes using the following XML syntax that is illustrated via an example:

```
<TestbedAvailability>
  <Domain name="nitos">
    <AvailableSpectrum>
      <Channel>1</Channel>
      <Channel>2</Channel>
    </AvailableSpectrum>
    <AvailableNodes>
      <Node>node001</Node>
      <Node>node003</Node>
    </AvailableNodes>
  </Domain>
  <Domain name="sb2">
    <AvailableSpectrum>
      <Channel>3</Channel>
      <Channel>4</Channel>
    </AvailableSpectrum>
    <AvailableNodes>
      <Node>node001</Node>
      <Node>node002</Node>
    </AvailableNodes>
  </Domain>
</TestbedAvailability>
```

The *TLQAP* controller now knows which nodes and channels are available, but it also needs to know which are the experiment link requirements. For this reason the scheduler, which has already interacted with the user, issues the following link quality request:

```
<NetTopoGraphReq>
  <link id="1" type="bidirectional">
```

```

<MaxChannelUtil>30</MaxChannelUtil>
<direction>
  <MinRate>10</MinRate>
  <MinPDR>60</MinPDR>
  <TransPower>60</TransPower>
</direction>
<direction>
  <MinRate>10</MinRate>
  <MinPDR>60</MinPDR>
  <TransPower>60</TransPower>
</direction>
</link>
.....
</NetTopoGraphReq>

```

This request describes independently for each link and direction the minimum requirements. Note that the maximum channel utilization refers to the maximum allowed percentage of channel that may be occupied by testbed external devices. The *TLQAP* system should determine and reply with all the links that meet these requirements. The reply XML syntax is as follows:

```

<NetTopoGraphRes>
<link id="1">
  <node src="Node001">
    <connection dest="Node005">
      <Channel>48</Channel>
      <Rate>10</Rate>
      <PDR>60</PDR>
    </connection>
    <connection dest="Node007">
      <Channel>4</Channel>
      <Rate>12</Rate>
      <PDR>70</PDR>
    </connection>
    .....
  </node>
  <node src="Node005">
    <connection dest="Node001">
      <Channel>48</Channel>
      <Rate>10</Rate>
      <PDR>60</PDR>
    </connection>
    <connection dest="Node007">

```

```

    <Channel>8</Channel>
    <Rate>15</Rate>
    <PDR>60</PDR>
  </connection>
  .....
</node>
  .....
</link>
</NetTopoGraphRes>

```

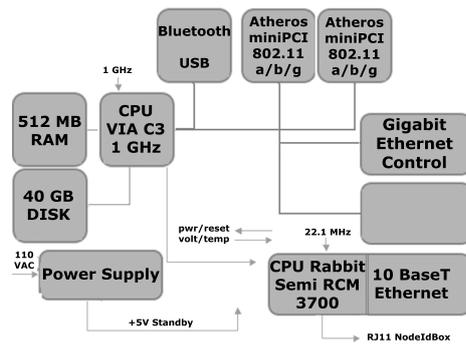

(a) ORBIT Node Schema.



(b) ORBIT Node.

Figure 10: ORBIT-Like Nodes

TLQAP controller is now ready to perform the *TLQAP* based measurements. Firstly, it inquires the testbed scheduler to get the list of available nodes and channels on which *TLQAP* measurements may be performed. Then the system uses OMF support to load *TLQAP* images to the nodes and start *TLQAP* click instances. The transmission sessions are sequentially started on each node for all available channels, rate and power combinations. The controller stores the reported transmission time after a session finishes. Finally, when the last session is finished, the controller collects all the counter maps, processes results and replies to the scheduler.

Admittedly, determining the connectivity between a group of nodes that belong to a non RF isolated testbed, immediately before using them, does not necessarily mean that the observed quality of all the links will remain stable when the actual experiment is deployed. At least, *TLQAP* increases the probability that the chosen nodes will satisfy the experiment needs. To further strengthen this probability, we have developed a mysql based history log for the quality of each testbed link on all available channels. Each time *TLQAP* is deployed and results are collected and processed, the database is inquired for the quality of the chosen links on each channel around this time of day and for the past week.

If the link quality and/or channel does not appear to have stable availability, the system tries to find a substitute node if it is possible. After this process is finished, the database is populated with the current link quality measurements that have been recorded by *TLQAP* which will be used for future reference. In order to increase the density of the history log and improve its validity, we schedule *TLQAP* sessions for all the idle testbed nodes and channels, every fifteen minutes, for the sole purpose of expanding the history log.

3.4 EVALUATION

To evaluate *TLQAP* we have used our OMF [95] testbed that is deployed on the main building of our department which is located in the center of Volos city in Greece. The testbed currently features a total of 9 nodes which are placed both outdoors and indoors. Around the testbed area and out of the testbed context, are independently operating 56 access points which are located in the nearby buildings. Notably, most of the neighbors use 802.11g channels during business hours. Below we describe our testbed nodes and organization in detail and we then present and compare *TLQAP* system with the existing bandwidth measurement tools approach, that could have been used instead on this testbed.

3.4.1 Testbed Description

Our testbed is comprised of ORBIT-like nodes, as depicted in Fig. 10(b). More specifically, in Fig. 10(a) we can see a diagram of an ORBIT node design. Each node consists of a 1GHz VIA C3 processor, 512MB of RAM, 40GB of hard disk, two ethernet ports and two miniPCI slots which are used to host two 5212 Atheros WiFi cards.

All the nodes are connected through wired Ethernet with the testbed's server - *console*. On console we have all the required testbed services running. These services are both network services, such as Dynamic Host Configuration Protocol (DHCP) server which gives IP address to the nodes, Domain Name System (DNS) server which gives names to the nodes, Network File System (NFS) server and OMF services. We also maintain a web server where we keep the web interface of our scheduler. On this server, we also keep some scripts

mandatory for remotely booking the nodes and a MySQL server for keeping records of the testbed status at each slot.

After the user is assigned some nodes for a certain amount of time on the testbed, he may log into console and start using the testbed. The selected system image is loaded on each node via the wired Ethernet interface. More information about our testbed (e.g. node connectivity graph) can be found on our web site [14].

3.4.2 Using an existing bandwidth measurement tool

The most popular approach to assess the quality of a wireless link between testbed nodes is using a bandwidth measurement application. Unfortunately, in this approach, the default network stack allows packet broadcasts to be transmitted only at the basic rate, so the *TLQAP* style transmit-receive sessions cannot be used with these tools. Therefore, for each node that is within range, the classic single addressed transmit-receive flows must be used. In our case we used the *iperf* tool as follows. For every fixed rate, channel and power combination we deploy *iperf* transmitter-receiver pairs for UDP unicasts on the respective nodes and for each link direction. *Iperf* provides results every second and usually needs to receive packets at least for three seconds to start reporting the actual throughput.

Depending on the current fixed rate, the *iperf* packet generator is configured to saturate the MAC layer. We have seen in practice, after performing numerous experiments on free channels, that for *iperf* default configuration the observed application level throughput of a high quality single link direction between two testbed nodes, is 55% of the (fixed) transmission rate. Therefore, if the *iperf* reported throughput is less than 55% of the used transmission rate we assume that the channel is not totally free. The free channel ratio is calculated by dividing the observed throughput by the maximum throughput that can be observed in practice (55% of the transmission rate). Moreover, *iperf* receiver reports the actual packet delivery ratio and during the measurements we have disabled 802.11 support for low level acknowledgements and retransmissions.

3.5 NITOS CONNECTIVITY TOOL

The gradually growing need for testbed use so as networking algorithms to be validated in real environment, has given rise to optimal utilization of testbed resources. Towards this direction, we present a new management tool that is used for assessing channel quality information in wireless testbed deployments. NITOS Connectivity Tool retrieves data concerning link quality measurements, for providing testbed users with useful information about choosing nodes that occasionally satisfy the requirements (link quality, connectivity) needed, for their experiments. NITOS connectivity tool is a full-fledged managerial tool that exploits testbed utilization by letting testbed users have a complete view about testbed's nodes. This tool allows a more sophisticated way to optimally choose network resources of a testbed.

In this demo, we will present a management tool for assessing channel quality information. The tool was developed for NITOS testbed and measures channel connectivity among wifi interfaces. NITOS is a wireless testbed, located in Volos, Greece with 15 nodes, each node equipped with two wifi interfaces. It is deployed on Computer & Communication Dept. University of Thessaly building. NITOS testbed topology is depicted on the left part of Fig. 1. Although the NITOS connectivity tool was developed on NITOS testbed, it can be adapted for use on any wireless testbed, with minor modifications. NITOS connectivity tool is a NITOS scheduler C.[7] component, which is used for resource allocation on NITOS testbed.

We have implemented NITOS connectivity tool, based on TLQAP [104], which is a protocol, that is used to assess interconnection topology and link quality by estimating packet delivery ratio (PDR) in downlink communication at each node's wifi interface for all requested channel, rate and transmission power combinations. Specifically, TLQAP builds a measurement history log and creates a channel utilization profile, and stores that information in a database that is used for link quality information retrieval by NITOS connectivity tool.

NITOS Connectivity Tool is comprised of three entities: a web interface, a database and a set of .dot scripts. The web interface is the interactive tool that an experimenter uses to choose testbed nodes for some time and it is depicted on the right side of Fig. 1. A user enters the NITOS Connectivity tool through NITLAB's wiki <http://nitlab.inf.uth.gr>. Now, the user has the ability to navigate through testbed's site and select "*Scheduler* → *Topology-Connectivity*" menu.

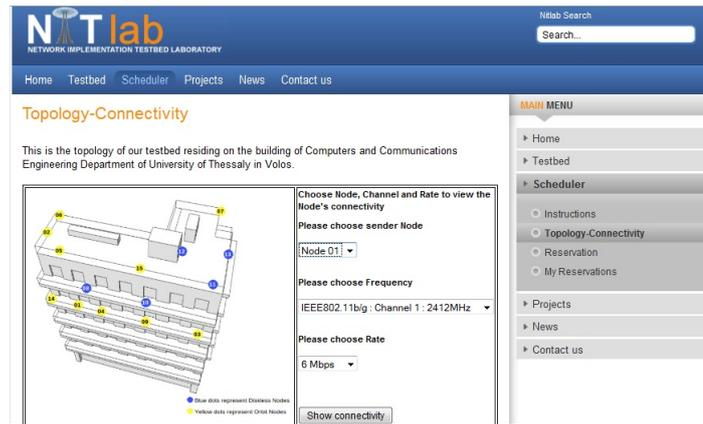

Figure 11: NITOS Connectivity Tool

Specifically, at first the user selects through web interface, by using a drop-down menu, a sender node that he/she wants to check and might want to use in testbed. Then the user is prompted to select an operating frequency among IEEE 802.11 communication standards 802.11a/b/g and selects the operating rate. Then, he/she goes to the final step where he submits his/her query concerning the link quality of a certain node. In sequence, the tool seeks to a database where the channel quality results are stored and retrieves the information that corresponds to the particular query. This information with the use of .dot files that are used to depict graphs are presented to the users. On Fig. 2, the downlink communication link quality for node 4 among its neighbor nodes is illustrated. Each node is indicated by a circle and the PDR of each link is reported upon edges that indicate link connectivity to certain node's wifi interfaces. Those interfaces are reported with their MAC addresses, with an arrow showing to the node where they belong.

3.5.1 Experiments and Results

We performed a series of experiments in order to: i) verify that *TLQAP* properly determines PDR and channel utilization, ii) evaluate the contribution of the history log and iii) assess the scalability of *TLQAP* approach. Moreover, in some cases we compare *TLQAP* with the *iperf* approach. Note that our testbed nodes are not tightly located, so some nodes cannot directly communicate and channel interference may not be the same for all the nodes as well.

We first examined the reported PDR using both *TLQAP* and *iperf* approaches on channel 48. We chose this channel because it is not being used by any neighbour and it is guaranteed to be interference free from any factor that is not

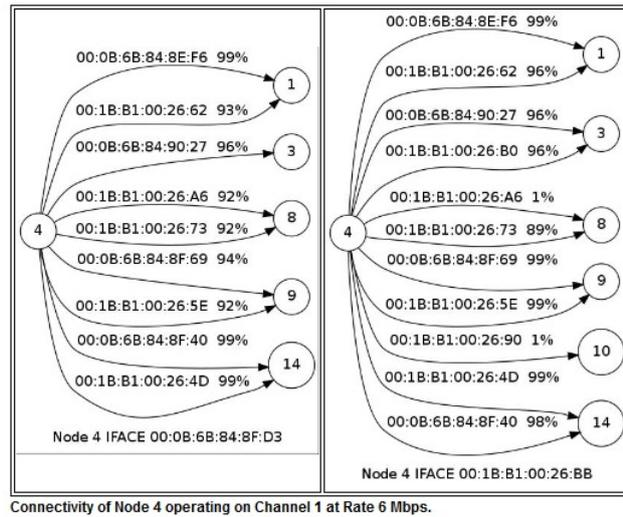

Figure 12: Link Quality for node 4

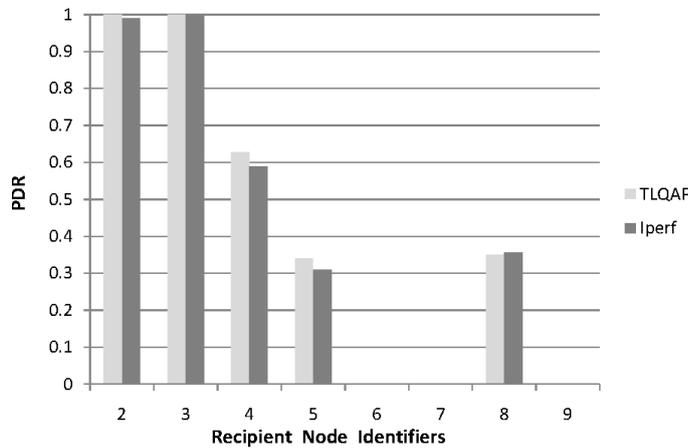

Figure 13: *TLQAP* and *Iperf* PDR measurements at nodes 2-9 on a free channel and fixed rate. The transmitter is node 1

under the testbed administration control. In Fig. 13 we present the packet delivery ratio (PDR) when node 1 transmits to the neighbors 500 1400 byte packets using *TLQAP* at 54Mbits/sec on channel 48. We have repeated the experiment using *iperf* reports for the same rate and channel and we depict the results on the same figure. As expected, there are no serious PDR deviations between the two approaches and they both determine it accurately.

The next figure depicts the channel 6 utilization by testbed external devices which is determined independently at each node. We have employed the history log to improve the probability that a channel will be available, because wireless network traffic usually follows a steady pattern during working hours on business days. Of course, history log can only provide rough estimations.

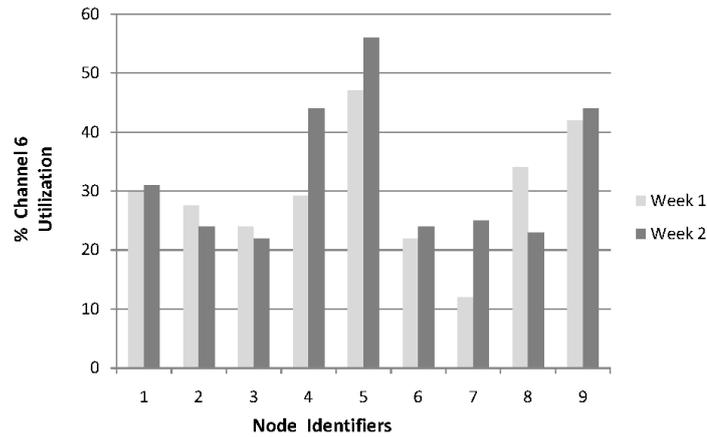

Figure 14: Average channel 6 utilization by testbed external devices for 2 consecutive weeks. (measured at each node between 11:00a.m and 11:20a.m)

In Fig. 14 we present the average channel 6 utilization that has been observed for two consecutive weeks, only on business days, in the time frame between 11:00a.m and 11:20a.m. On average, 30% of channel 6 is occupied each second for testbed external transmissions. For these measurements we transmitted 1000 packets during each *TLQAP* session.

The basic advantages of *TLQAP* approach over the application level measuring tools regarding the measuring delay are i) the use of a single session per node, transmission rate and channel and ii) the fact that the layer 2 implementation can accurately determine when actual packet transmission takes place and allows a fixed number of consecutive packet transmissions to provide accurate delay measurements.

On the contrary, application level bandwidth measurement tools need to generate traffic that saturates all the lower layer buffering mechanisms and to observe the reception side for a fixed amount of time to make sure that they are capturing the actual throughput. *Iperf* needs 3 seconds for each link direction and, for example, for all 9 nodes of our experimental setup 3024 seconds are required to exhaustively check all links on 14 channels and 9 different rates using fixed transmission power.

In Fig. 15, we present the *TLQAP* delay for the same example and for different sizes of session packet numbers. As it is depicted, if we use 1000 packets during each broadcast session *TLQAP* approach is 4 times faster than *iperf* and produces the same results. Note that during these experiments, we did not employ any additional support for the *iperf* approach to examine if there is any

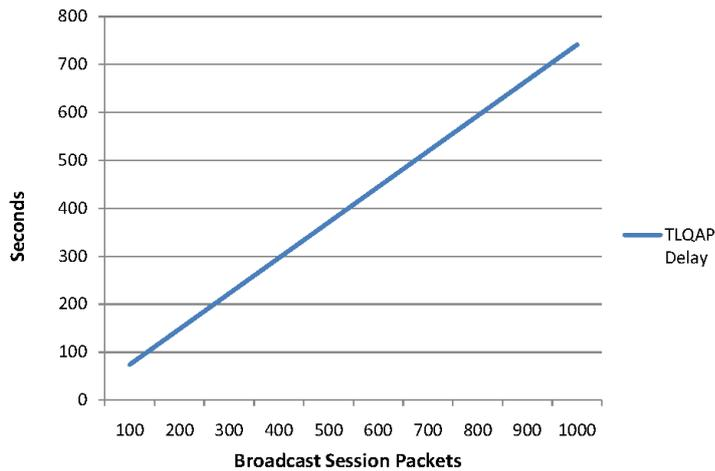

Figure 15: *TLQAP* measured delay for inspecting link of 9 nodes on 14 channels and 9 different rates

connectivity at all (e.g. via ping) between two nodes, which would avoid performing measurements between nodes that are not directly linked. As we have explained, *TLQAP* performs all broadcasts at all available rates anyway, even for the sole purpose of determining channel utilization.

3.6 RELATED WORK

Adhoc routing protocols for wireless mesh networks, employ link quality metrics that can be updated quickly without being particularly intrusive and determine the best routing path to a destination. Most popular of these metrics like ETX [45], mETX [74], ETT [53] are based on the PDR and/or the average packet transmission delay, which are the only measurements that must be performed at each node for all its immediate links. Exactly as it happens with *TLQAP*, these routing protocols calculate PDR and transmission delay by periodically transmitting the so called packet probes at all available rates, without using 802.11 level acks and retransmissions. Increasing the probing frequency, results in more accurate estimations but also increases the bandwidth overhead. For this reason, in routing protocols, packet probes are emitted from each node every few seconds. Since *TLQAP* has been designed for offline measurements it can use relatively large number of consecutive probe packet broadcasts that increase the accuracy of the estimations and, most importantly, better determine channel traffic. Moreover, designers of link quality metrics can take advantage of *TLQAP* feedback and use it as a reference to evaluate the performance of their design during an experiment.

In [55] authors determine channel traffic by sending back-to-back just two probes and then measure their dispersion. They have observed in their experiments strong correlation between probe packet dispersion and traffic in the air. While we can use this approach in *TLQAP* to determine channel traffic by implementing the proposed probe priority queue scheme, we decided to estimate the average dispersion of large sets of consecutive packet probes. We believe that this approach enhances the offline measurements because it captures activity for a wider time frame. This is also why we have used history log as well.

3.7 CONCLUSION

Distributing the network bandwidth between experiments on wireless testbeds can be a very complicated task, especially when the testbed nodes are not operating in an RF isolated environment. The respective management frameworks should employ support to frequently inspect the link quality between the nodes. On testbeds where the nodes are in fixed locations, a history log of quality measurements can significantly increase the probability that a link will retain the measured quality during the actual experiment. What is more important, the testbed user has a good reference of the achievable bandwidth between the reserved nodes and can better evaluate the observed performance of the deployed experiment. Management framework extensions that measure performance should feature a low level subsystem that can bypass the network stack buffering and retransmission mechanisms, to make more accurate measurements and perform faster. *TLQAP* system design addresses the aforementioned considerations.

Part II

TESTBED EXPERIMENTATION

ON THE IMPLEMENTATION OF RELAY SELECTION STRATEGIES FOR A COOPERATIVE DIAMOND NETWORK

In this chapter, we present an implementation design of a TDMA protocol for the canonical diamond-topology network containing a source, two relays and a destination (single unicast session). Getting inspired by the established Lyapunov-methodology, we propose an online strategy for the relay selection/scheduling problem. In contrast to existing works, we implement this strategy inside the proposed TDMA protocol in order to operate over a CSMA enabled Wi-Fi infrastructure-less network. We elaborate a network controller within the TDMA frame to solve a global optimization problem at each time slot in a centralized manner. In our formulation, we consider the class of scheduling policies that select concurrently a non-interfering subset of links. Our architecture is tailored to achieve the objectives of stabilizing the network and either maximizing throughput or minimizing the total power consumption. Our scheme has been implemented and tested thoroughly through experimentation in the NITOS wireless testbed by exploiting Wi-Fi technology features. The results revealed significant increase in networking efficiency for throughput maximization.

Keywords – Relay Selection, Optimal Centralized Scheduling, TDMA, Wi-Fi Testbed Implementation.

Related Published Work:

- C.[5] Apostolos Apostolaras, Kostas Choumas, Ilias Syrigos, Iordanis Koutsopoulos, Thanasis Korakis, Antonios Argyriou, and Leandros Tassioulas. “On the implementation of relay selection strategies for a cooperative diamond network.” In *Personal Indoor and Mobile Radio Communications (PIMRC), 2013 IEEE 24th International Symposium on*, pages 1753–1758. IEEE, 2013.
- C.[3] Mahmoud Hadeef, Apostolos Apostolaras, Jim O’Reilly, Alain Mourad, and Belkacem Mouhouche. “Cooperative multicast resource allocation strat-

egy.” In *Proceedings of the Wireless and Communications Networking Conference (WCNC)*, 2014

- C.[4] Mahmoud Hadeif, Apostolos Apostolaras, Jim O’Reilly, Alain Mourad, Belkacem Mouhouche, Iordanis Koutsopoulos, Thanasis Korakis, and Leandros Tassiulas. “Energy aware buffer aided cooperative relay selection.” In *Proceedings of the Wireless and Communications Networking Conference (WCNC)*, 2014
- C.[6] Mahmoud Hadeif, Apostolos Apostolaras, Alain Mourad, Jim Oreilly, Iordanis Koutsopoulos, Thanasis Korakis, and Leandros Tassiulas. “Energy efficiency performance evaluation of back-pressure driven cooperative relay selection for wimax systems.” In *Proceedings of the 6th International ICST Conference on Simulation Tools and Techniques*, pages 258–267. ICST (Institute for Computer Sciences, Social-Informatics and Telecommunications Engineering), 2013.
- D.[1] Apostolos Apostolaras, Kostas Choumas, Ilias Syrigos, Giannis Kazdaridis, Thanasis Korakis, Iordanis Koutsopoulos, Antonios Argyriou, and Leandros Tassiulas. “A demonstration of a relaying selection scheme for maximizing a diamond network’s throughput.” In *Testbeds and Research Infrastructure. Development of Networks and Communities*, pages 408–410. Springer Berlin Heidelberg, 2012.

4.1 INTRODUCTION

Cooperative networking implies the notion of assistance among multiple nodes to cooperate for forwarding a packet when networking conditions are insufficient to favor direct communication. This can be achieved thanks to the diversity in communication as a means of provisioning different routes and schedules between a source and a destination via intermediate relay forwarders. Occasionally, multiple networking paths exhibit good transmission quality and offer better transmission opportunities for wireless communication. By exploiting this kind of diversity through cooperative schemes, we aim at improving transmission quality and system performance.

In this work, we design a TDMA protocol that elaborates a centralized network controller to activate scheduling and relay selection decisions towards power minimization or throughput maximization in a cooperative diamond

network. Those decisions are taken at each time instance according to networking status conditions, so that the requirements which the aforementioned objectives impose can be met. We exploit assistance of multiple nodes to cooperate for forwarding a packet when networking conditions are insufficient to favor direct communication. In our previous work [31], we demonstrated the feasibility of this implementation scheme. In a sequel work [30] we presented a solution that is formed but not limited, to provide an implementation framework for optimization in diamond network topologies through a centralized TDMA access scheme. Relying on the Lyapunov drift technique from optimization theory [85, 56] we derived a concrete mathematical solution that converges in time and suffices the networking constraints while also optimizes key objectives keeping stability ensured. In this work, we extend the previous works experimentation part justifying the power efficiency of the proposed algorithms through extensive experimentation and measurement collection. Moreover, we provide details for the implementation and the modifications applied on open-source software for delivering this framework, that can be transparently used to commercial *off-the-shelf* hardware.

An important parameter that we consider is the sensitivity of the proposed solution in key objectives against the total average delay or data queue backlogs. By exploiting the features of the Lyapunov drift technique, we employ a tunable V parameter that controls the objective goal. The objective goal is mapped to a suitable *penalty* function and it is incorporated inside the equation of drift expression (see [85, 56]). Scheduling actions are taken every slot t to greedily minimize the drift expression plus the $V \times \text{penalty}$. This is employed by the proposed TDMA frame design which defines separate periods for networking status collection, message passing for control decisions and actual transmission. Different values of V tune the flexibility of the proposed scheme to act in terms of a greater degree of sensitivity towards the key objective - *penalty* function under optimization, creating a tradeoff between average delay and the actual goal that we seek to attain, i.e. total average power consumption vs. total average delay. Therefore, the proposed solution can adapt accordingly to the volatile networking state information and be robust and agile in rich interfering or low gain communication environments.

While prior work in wireless cooperative networks has shown that enhancement in communication can be achieved in terms of throughput performance, low delay, low power consumption and QoS guarantees, this work realizes the potential of centralized networking for taking online smart scheduling deci-

sions to enforce several networking objectives such as throughput maximization or power minimization. Intellectual merit of this work relies on the following contributions:

- We design and implement a TDMA access scheme for packet forwarding, which is backwards compatible with CSMA enabled commercial devices and it is also effectively applied upon Wi-Fi networks using off-the-shelf equipment.
- We elaborate a centralized network controller in the TDMA frame to enforce scheduling and relay selection policies, relying on Lyapunov optimization.
- We explore performance enhancements in terms of either throughput optimal or power efficient scheduling by implementing centralized networking.
- We seek to obtain desired tradeoffs between networking performance efficiency metrics, such as power consumption (or system throughput) vs. networking delay.
- We implement the proposed centralized relay selection algorithm for Wi-Fi operational networks, by exploiting Open Source Software capabilities of the Click Router [72] and the Ath9k driver [2].
- We achieved a *per packet* power and rate configuration by exploiting the *Radiotap header* [94].
- We tested and evaluated our solution on the NITOS [13] wireless testbed.

The rest of this Chapter is organized as follows. In Section 4.2, we describe significant related works in the field of cooperative networks. Then in Section 4.3, we give a system model description for the cooperative diamond network under study. Then in Section 4.4, we explain details about the relay selection policies which elaborate the Lyapunov optimization technique [85, 56]. In Section 4.5, we describe the methodology to design a centralized algorithm exploiting a TDMA access scheme upon conventional CSMA Wi-Fi networks. Next, in Section 4.7, results considering the implemented and tested TDMA scheme, in the NITOS testbed [13] that features commercial off-the-shelf Wi-Fi devices by using OpenSource Software are discussed. Finally, in Section 4.8 we conclude and present prospects for future work.

4.2 RELATED WORK

In this section, we describe previous works in the literature, studying the relay selection problem in cooperative wireless networks. A notable number of publications have been presented in the area of cooperative relaying, as it is briefly summarized below. The seminal information-theoretic works of Cover *et al.* [46] and Schein *et al.* [98] introduced a study for the capacity of relay networks. The conventional three node relay model was studied by Van der Meulen in [110]. Berry *et al.* in [114, 113] study cooperative communication models that incorporate stochastic traffic arrivals for multiple sessions as well as the related queuing dynamics in all network nodes. A two-hop diamond network topology is considered for evaluation purposes, where N relays act as intermediary nodes for forwarding the traffic for a particular source-destination pair, and a half-duplex communication constraint is also imposed.

Guan *et al.* in [59] investigate the problem of joint spectrum management and relay selection for a set of sessions in order to utilize an interference limited infrastructure-less network. They rely in variational inequality theory to propose distributed solutions to that problem. Zhang *et al.* in [115] formulated the problem of distributed relay selection as a Stackelberg game and proposed a framework for resource management in cooperative cognitive radios. Madan *et al.* in [82] study a cooperative wireless network where a set of nodes cooperate to relay in parallel the information from a source to a destination using a *decode-and-forward* (DF) approach. The source broadcasts the data to the relays, some or all of which cooperatively beamform to forward the data to the destination.

Halabian *et al.* in [62] considers a relay selection problem for multiuser cooperative wireless networks and propose a throughput optimal relay selection policy that stabilizes the system for all arrival rates in the interior of the stability region. The optimal policy is shown to be equivalent to finding the maximum weighted matching in a weighted bipartite graph at each time slot. The Hungarian algorithm is employed to solve the maximum weighted matching for graph G . A similar approach of formulating the relay selection problem in terms of a bipartite graph is presented in Gkatzikis *et al.* work [58], where the joint problem of power control and relay selection is considered.

The influential work of Tassiulas *et al.* in [105] established a framework for indicating throughput optimal scheduling in radio networks by introducing the

well known backpressure algorithm that exploits queueing backlogs as system state information to derive an optimal scheduling policy. As an enhancement of the previous works Neely in [86] developed a dynamic control strategy for minimizing energy expenditure in a time varying wireless network with adaptive transmission rates. The aforementioned works set up the foundation for creating a concrete framework [85, 56] for resource allocation in several wireless network types. This framework provides a solid presentation of the theory of Lyapunov optimization applied on queueing networks and have formed the foundations for the work presented in this work for enabling an extensible elaboration for cooperative relaying networks.

Apart from theoretical works in the literature, there are several studies considering cooperative implementations in infrastructure-less wireless networks. To the best of our knowledge the first implementation were the works of Liu *et al.* in [79] and Korakis *et al.* in [75, 76] where authors designed a cooperative MAC protocol, simple and backward compatible with the legacy IEEE 802.11 standard. In those works, each low data rate node selects either direct transmission or assisted-relay transmission by utilizing a *CoopTable* where it stores potential helper/relays rate information. Neighboring nodes exchange their rate tables so as to automatically decide whether a packet will take longer to transmit between two nodes directly or via a cooperative relay assistance. In another work [88], Nikolyenko *et al.* presented a hardware-independent data link layer design for cooperative retransmission support to the Linux kernel wireless SoftMAC implementation (`mac80211`). Laufer *et al.* in their work [77] design a throughput-optimal backpressure architecture for wireless multi-hop networks. A mesh network is transformed into a wireless switch, where packet routing and scheduling decisions are made by a backpressure scheduler elaborating a TDMA access scheme in a centralized manner. Although the proposed framework was evaluated in a Wi-Fi testbed and revealed significant performance improvements, an important drawback of this work is the inability to be seamlessly applicable on commercial Wi-Fi devices, since it was implemented hard-coded on the firmware of a particular vendors WiFi card.

In [41], Chiochan *et al.* propose an effective buffer allocation algorithm, called buffer equalized opportunistic network coding (BE-ONC), to dynamically exploit buffer spaces at a relay node of a relay-based IEEE 802.11 network by making use of the Click Modular Router Framework [72].

4.3 NETWORK MODEL

We consider the two-hop diamond network depicted in Fig. 16 consisting of a source node S , two relay nodes R_1, R_2 and a destination node D . We denote with $\mathcal{N} = \{S, R_1, R_2, D\}$ the set of wireless nodes in the network. The relays help the source node when channel conditions (or other factors such as queue congestion, power consumption) do not favor direct source-destination transmission by forwarding traffic through alternative links. Time t is slotted. We also define a set of links $\mathcal{L} = \{SR_1, R_1D, SR_2, R_2D\}$ that are interference limited and impose the constraint that, at any time slot t , only one of the two link pairs as shown in Fig. 16 can be activated. Namely, the first one is the transmission from S to R_1 and from R_2 to D , and the second one from S to R_2 and from R_1 to D . Moreover, we assume the existence of a system controller which lies in the source node S and it is denoted by $\mathbf{a}(t)$. Its role is to enable the two feasible scheduling actions in a *centralized* manner. Thus, controller can take the following values $\mathbf{a}(t) \in \{\mathbf{1}_{\{SR_1, R_2D\}}, \mathbf{0}_{\{SR_2, R_1D\}}\} = \{1, 0\}$ relying on collected system state information from neighboring nodes. Each node $i \in \mathcal{N}$ maintains a backlog queue Q_i for storing received data packets in the network layer. We also make the following assumptions:

- Packet injection $A(t)$ in the network takes place only on the source node with rate λ_S . All other nodes receive intra-network traffic, therefore $\lambda_i = 0, \forall i \in \mathcal{N} - S$.
- Without loss of generality, power consumption $P_{ab}(t)$ in node a for transmitting to node b is spent only during packet transmissions while receptions are *free of charge* (the model can be extended to include reception costs as well). As a result, the destination does not spend any power, since it never transmits any packets.

The concept of this setup is to enforce a switching between relay selection in order to achieve the objective of the problem under optimization. In this work, we consider either *Maximum Throughput* or *Minimum Power* optimization. This concept becomes apparent as the solution on the optimization problem reveals a link-pair activation rule that determines the scheduling policy. A significant point that needs clarification is that the activation rule captures the changes in network queueing and system dynamics denoted by $\mathcal{S}(t) = \{\mathcal{S}_{SR_1}(t), \mathcal{S}_{SR_2}(t), \mathcal{S}_{R_1D}(t), \mathcal{S}_{R_2D}(t)\}$ over time. Therefore, the scheduling policy indicates the optimal schedule towards the optimization objective each

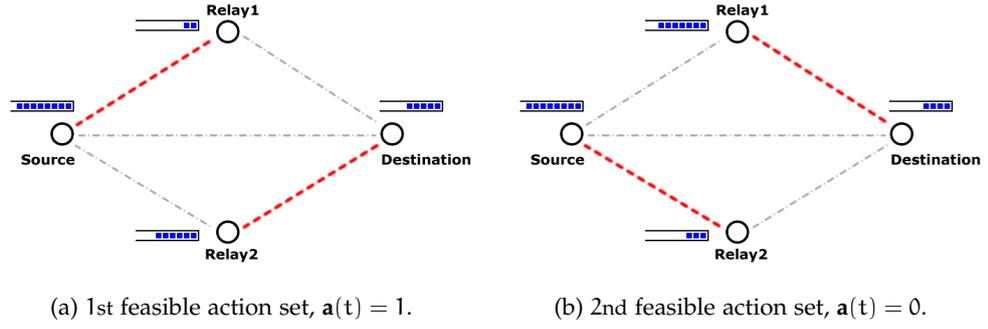

Figure 16: Relay Selection policy: Controller $\mathbf{a}(t)$ enables communication on particular links each time. Red dotted lines indicate active schedules.

time slot, choosing the appropriate pair from the feasible set. The selection of a schedule link-pair over another does not cause starvation in terms of pure selective activation, since the denser an activation of a link pair occurs, the less favorable is to be selected for activation on the next time slot.

4.3.1 Data Transmission and Queueing

Data are delivered to queueing buffers located in each node $i \in \mathcal{N}$, for transmission over the wireless links $l \in \mathcal{L}$. Let $Q(t)$ represent the current number of packets or number of bits in the queue. The queue backlog evolves according to the following equation:

$$Q_i(t+1) = [Q_i(t) - \sum_b \mu_{ib}(t)]^+ + A_i(t) + \sum_a \mu_{ai}(t), \quad (1)$$

where $[\cdot]^+$ denotes the $\max(\cdot, 0)$ and $A_i(t)$ are the exogenous arrivals on node i at time slot t (as previously mentioned, only the source node S receives exogenous arrivals in the network). The transmission rate $\mu_{ab}(t) = \mu_{ab}(\mathcal{S}_{ab}(t))$ in the link (ab) on slot t depends on the link channel state condition $\mathcal{S}_{ab}(t)$. We assume that the channel state $\mathcal{S}(t)$ is known at the beginning of each time slot t and remains constant over its duration, but it can be variable throughout time slots. The $\sum_a \mu_{ai}(t)$ is the cumulative internal traffic arriving at node i at time slot t and $\sum_b \mu_{ib}(t)$ is the traffic served from node i to all other nodes at slot t .

4.3.2 Definition of Problem Optimization Objectives

Given the topology above and considering the channel state and queue size variations, the objective is to designate a relay selection/scheduling policy that determines unicast transmissions activation in the cooperative network with the separate goals of either **1) minimizing the total power consumption** or **2) maximizing the total throughput** of the network. To this end, we formulate two different problems based on Lyapunov drift theory [85, 56] and we incorporate a *penalty* function that reflects the optimization target along with a *tuning* parameter V into the respective resource objective optimization.

Power Minimization: The objective is to keep the total power consumption low (i.e. to increase the network's lifetime in case of limited power capacity in handheld devices) while also stabilizing the networking queues. Hence, we seek to select schedules so as to minimize the total power consumption in the cooperative network. We impose a per node total power constraint (in addition to the scheduling constraints shown in Fig. 16 and the queue's evolution described by Eq. (1)) in order to model actual hardware limitations. The variable V can be used as a tuning parameter to provide a suitable power performance-networking delay tradeoff. Specifically, the analysis suggests that the proposed policy can achieve a total power expenditure arbitrarily close to the optimal value (for sufficiently large V), at the cost of increased queue congestion and a corresponding delay.

Throughput Maximization: The objective now is to select schedules so as to maximize the total traffic rate of the cooperative network subject to the same constraints (power, schedules etc) as in the power minimization problem. We also impose a per-node power constraint that reflects the maximum transmission power for a single node, however we have been interested on selecting schedules each time slot t that will eventually increase the total throughput. An appropriate selection of the tuning parameter V , makes the initial problem of *power minimization* to be reduced to *throughput maximization*. By observing the power minimization formulation, if we set $V = 0$, we get a max weight scheduling decision algorithm. Therefore, we can consider throughput maximization as a special case of the power minimization problem.

The desired tradeoff between the achieved optimization objective and congestion-induced delay can be expressed clearly, by selecting the V parameter value. Moreover, an important characteristic of both policies which becomes appar-

ent later, is that even though we consider a joint optimization problem, the power allocation and scheduling decisions are eventually decoupled (i.e. we first compute the optimal power allocation for a slot, and then determine the schedule for this allocation). We examine next the two objectives in more detail and we provide the scheduling decision rules.

4.4 OPTIMIZATION FRAMEWORK

Consider again the wireless diamond network of Fig. 16. In order to establish a policy that chooses between two actions from the feasible set of schedules and activates them each time slot t , so that both networking stability and performance optimization to be achieved, we rely on the Lyapunov drift technique. Mathematical analysis and proof is given in APPENDIX.

Solution: The scheduling policy rule is deduced by minimizing the bound on the Lyapunov drift (see [105, 56, 86]) expression given in Eq. 2 with respect to $a(t)$. The solution follows simply, and the network controller indicates power efficient schedules by setting $a(t) = 1$ and selecting $\{SR_1, R_2D\}$ for activation, when the expression inside brackets is negative ($[\cdot] < 0$), otherwise it sets $a(t) = 0$ and activates $\{SR_2, R_1D\}$.

$$a(t) \left[V (P_{SR_1}(t) + P_{R_2D}(t) - P_{SR_2}(t) - P_{R_1D}(t)) - Q_S(t) (\mu_{SR_1}(t) - \mu_{SR_2}(t)) + Q_{R_1}(t) (\mu_{R_1D}(t) + \mu_{SR_1}(t)) - Q_{R_2}(t) (\mu_{R_2D}(t) + \mu_{SR_2}(t)) \right] < 0 \quad (2)$$

The drift formula incorporates a tunable V parameter for calibrating the networking delay against the system performance objective, which is reflected through a suitable *penalty* function (power consumption). The higher the V value, the more the rule goes away from **backpressure** policy [105], sacrificing throughput for power reduction. The less the V value, the more throughput is achieved, however, with a significant expense on power consumption. We next examine three cases:

- a) $V = 0$, the power consumption expression is disregarded, and the problem reduces to stabilizing queues. It is indeed the **(maximum throughput)** approach implementing the **backpressure** policy with no consideration for the power consumption.
- b) $V \gg 0$, then power consumption expression dominates in the formula all the other queueing factors. The problem is reduced to select purely activa-

Rule 3: Maximum-Throughput.

$(\mathbf{V} = \mathbf{o})$	<i>Maximum-Throughput</i>
-----------------------------	---------------------------

<i>if</i>	$(Q_S(t) - Q_{R_2}(t)) \mu_{SR_2}(t) + Q_{R_1}(t) \mu_{R_1D}(t) >$ $(Q_S(t) - Q_{R_1}(t)) \mu_{SR_1}(t) + Q_{R_2}(t) \mu_{R_2D}(t)$
<i>then</i>	$\mathbf{a}(t) = 0$, Activate (SR ₂), (R ₁ D) Schedules.
<i>else</i>	$\mathbf{a}(t) = 1$, Activate (SR ₁), (R ₂ D) Schedules.

tion schedules that consume the least power without any consideration of queuing backlogs/congestion.

Rule 4: Power-Conservation.

$(\mathbf{V} \gg \mathbf{o})$	<i>Power-Conservation</i>
-------------------------------	---------------------------

<i>if</i>	$P_{SR_1}(t) + P_{R_2D}(t) > P_{SR_2}(t) + P_{R_1D}(t)$
<i>then</i>	$\mathbf{a}(t) = 0$, Activate (SR ₂), (R ₁ D) Schedules.
<i>else</i>	$\mathbf{a}(t) = 1$, Activate (SR ₁), (R ₂ D) Schedules.

- c) $\mathbf{o} < \mathbf{V} < \infty$, This is the intermediary regime where the *power-throughput* performance tradeoff is attained. For large values of \mathbf{V} the policy selects more power conservative schedules causing larger queues and induces larger networking delay. For small values of \mathbf{V} (close to zero) the power consumption becomes larger, while the queue congestion falls and the networking delay is reduced.

4.5 WI-FI IMPLEMENTATION

In this section, we consider a Wi-Fi implementation on the diamond relaying scheme of Fig. 16 by designing a centralized scheduling and relay selection algorithm. The adopted CSMA access scheme in Wi-Fi [102] networks prevents us from the direct appliance of this algorithm. We firstly seek to design an

Rule 5: Power-Minimization.

 $(\mathbf{0} < \mathbf{V} < \infty)$ *Power-Minimization**if*

$$\begin{aligned} & V(P_{SR_1}(t) + P_{R_2D}(t) - P_{SR_2}(t) - P_{R_1D}(t)) \\ & - (Q_S(t) - Q_{R_1}(t))\mu_{SR_1}(t) - Q_{R_2}(t)\mu_{R_2D}(t) \\ & + (Q_S(t) - Q_{R_2}(t))\mu_{SR_2}(t) + Q_{R_1}(t)\mu_{R_1D}(t) > 0 \end{aligned}$$

then $\mathbf{a}(t) = 0$, **Activate** $(SR_2), (R_1D)$ Schedules.*else* $\mathbf{a}(t) = 1$, **Activate** $(SR_1), (R_2D)$ Schedules.

implementation methodology, that describes the techniques that will be used in order to solve particular problems arising when parallel transmissions are activated, and latterly to present the complete Wi-Fi solution. Overcoming the Wi-Fi limitations includes a design of a TDMA frame and a method to suppress CSMA. The novelty of this implementation lies in its generality to enforce activation for scheduling and parallel transmission in Wi-Fi operated networks.

4.5.1 Implementation Methodology

Here, we primarily focus on enlightening the rationale behind the proposed implementation scheme, by presenting certain problems arising when parallel transmissions are activated, as in the case of the feasible activation link sets in the diamond network.

Packet Collision during Parallel Transmission in Single Frequency Operated Networks In a single frequency operated network, packets collide when parallel transmissions are enabled. This is depicted in Fig. 17 where we observe packets colliding when parallel transmissions (from S to R_1 and from R_2 to D) or (from S to R_2 and from R_1 to D) are activated. Even enabling CSMA protocol for collision avoidance, the expected throughput benefit from cooperative relaying technique will be lower due to the operation of the back-off mechanism. In order to overcome that obstacle the solution that we adopt, in our system design, is to separate the diamond network in two hops, where the links belong to the first hop (links from source to relays) and the links belong to the second

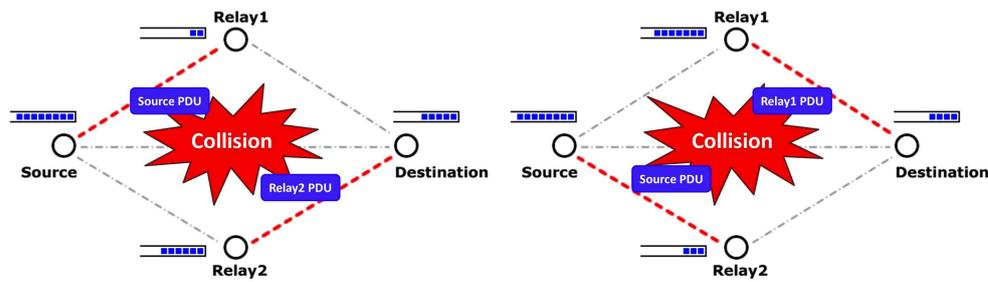

Figure 17: Packet collisions occurring when parallel transmission are activated.

hop (links from relays to destination) operate in different channels. In this way, parallel transmission in the frequency domain is orthogonal because the two active links can operate in different channel at the same time, see Fig. 19.

Packet Collision due to Limited Access on the Wireless Card Firmware

Let us consider the following scenario where the network controller takes a decision to activate two links for transmission (SR_1 and R_2D), after an active transmission session on the other set of links (SR_2 and R_1D). The problem that occurs is the following: Some packets might be left on the R_1 buffer in the MAC layer queue (from the previous schedule) and since there is no control of the transmission in the wireless card firmware, a collision with a packet coming from R_1 with any packet being transmitted in the active links (either SR_1 or R_2D) can occur (see Fig. 18). **Solution** In order to be able to prevent this situation from happening, we firstly must be able to precisely define the time periods where each scheduling decision is active and secondly to be able to stop packets that belong to different schedules rather than the nominal activated to be transmitted. In order to achieve the first goal, we design a TDMA access method where we orchestrate the transmission periods of each schedule with accuracy. For the second goal, we exploit the features of the Click Modular Router framework [72], and we choose to operate in OSI sublayer 2.5 where this framework stands. We maintain buffers on Click in order to store packets, because Click offers flexibility in packet gathering and handling. Moreover, we set the MAC layer queue equals to one and we allow packets entering the MAC layer of a particular node only when this node is selected for transmission. Clarifications about the Click framework architecture that we design are given in Section 4.6.

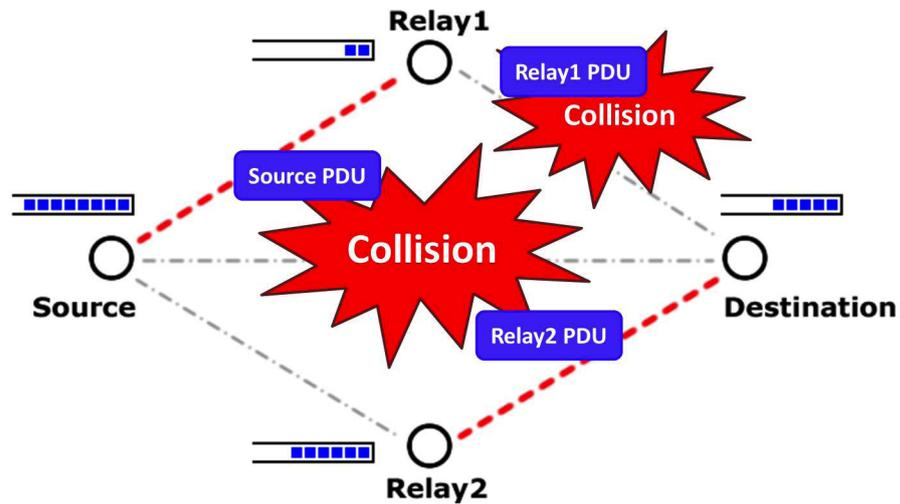

Figure 18: Packet collision due to limited control access on the wireless card firmware.

4.5.2 Design of a TDMA Frame

We elaborate a TDMA scheme and we activate it upon the Wi-Fi operation that uses carrier sense multiple access (CSMA) for accessing the shared medium. Per hop, the same frequency/channel is shared among users and the medium access is divided into different time slots. Thereby, active users transmit using their pre-allocated time slot.

For enabling the proposed TDMA access scheme we need a *centralized* control mechanism to gather network statistics such as temporal backlog loads or power consumption levels, so that the source node to obtain this information coming from the rest nodes inside the network. This control mechanism along with a mechanism that is used to pass messages-information about schedules, are employed inside a frame structure that provides accurate timing information to all nodes in the network. We explain the implementation details of this mechanism and we clarify building features in Section 4.6.

A TDMA frame structure showing a data stream divided into frames, and those frames divided into time slots, is depicted in Fig. 20. In T_1 interval, the mechanism for gathering network statistics is employed and the source node S is getting updated with the network state. In sequence the next interval T_2 marks the broadcast transmission, from the source node S to the relays R_1 and R_2 , and it is about the control packets that activate the appropriate schedules. The decision about the schedules has been pre-computed as soon as the source node was full aware about the updated network state and before T_2 starts. After successful reception of the control broadcast signal, relays are getting

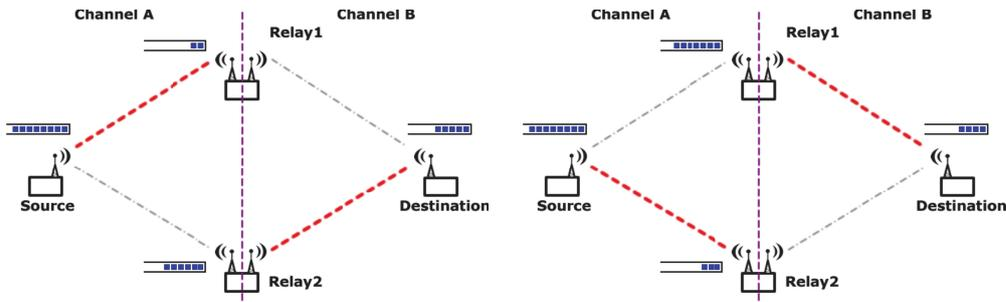

Figure 19: Feasible schedules are denoted with red lines. Each transmission per hop is enabled on different channel in order to avoid collisions when parallel transmissions occur.

synchronized and transmit or not, according to the feasible set of schedules in the interval T_3 .

Since T_2 and T_3 depend on the success in T_1 , a potential error or delay in T_1 , that may lead to a certain information unavailable to the centralized controller, will not severely inflict system's performance, since the network will continue to operate relying on the previous scheduling decision. However, this will cause on the long term, a convergence-delay to the optimization objective, as the number of errors increases, but with a significant robustness profit in terms of ensured queueing stability, a characteristic which comes from the Lyapunov drift optimization that allows the controller for capturing changes on the networking conditions each time slot t and adapt on the networking dynamics accordingly.

Time duration of the intervals in the frame structure are predefined in the system configuration setup and can be calibrated considering the volatility of the networking conditions. The denser the operations occurring in T_1 and T_2 are triggered, the more accurate the scheduling activations are and the network converges faster to the problem objective. However, this implies higher effort and increased overhead. Thereby, the TDMA access scheme comes with a cost due to synchronization issues along the time periods. Despite the aforementioned cost, the merit of this scheme is the actual performance improvement by realizing the centralized proposed policies, that is also verified by the experimentation results. Moreover, this TDMA scheme is not limited to a sole diamond network and can be extended to apply on expanded WLAN topologies. The diamond pattern is repeated among combinations of nodes, belonging on a WLAN that form canonical diamonds (each diamond can be activated in a round-robin way for avoiding extra collisions), as shown in Fig. 21, hence,

achieving also a transmission range extension. Below, we summarize the characteristics of the TDMA scheme that we exploit in this design setup:

- Centralized relay selection and scheduling.
- Precise timing and synchronization in transmissions.
- Dynamic slot assignment to the node-users.
- Advanced mechanisms for gathering and sending, network statistics and control information.

4.5.3 CSMA Protocol Suppression

The elaboration of the TDMA access scheme over the Wi-Fi operation in the considered diamond network is not so trivial since the CSMA access scheme that Wi-Fi adopts, not only restricts parallel transmissions in the same frequency-channel but also deteriorates system performance even if collision avoidance techniques such as back-off mechanism is incurred. Recall the diamond network of Fig. 16 consisting of a source node S , two relay nodes R_1 , R_2 and a destination D . In order to be able to assume that links are interference limited and impose the constraint that, at any time slot t , only one of the two sets of links (shown in (left-side) or (right-side)) can be activated, we need to enhance the design setup of the network. This can be achieved by operating the wireless network in different channels per hop and by equipping relay nodes with two wireless interfaces, in order to avoid packet collisions when two nodes (i.e. S and R_1 , or S and R_2) try to access the medium simultaneously [102]. Thus, first hop links ($S \rightarrow R_1$ or $S \rightarrow R_2$) use channel A and second hop links ($R_1 \rightarrow D$ and $R_2 \rightarrow D$) use channel B. The enhanced topology setup is illustrated in Fig. 19 and for the experimentation part, we elaborate this setup in the nodes of NITOS wireless testbed [13]. Moreover, considering the case where collisions might be occurred when packets from an active schedule (i.e. links SR_1 and R_2D) collide with packets from a previous active schedule (i.e. from link R_1D) due to the inability of controlling the wireless card firmware, we face this obstacle by moving the queues and the storing of packets to the Sublayer 2.5 using Click Modular router. Moreover, we set the maximum length size (capacity in terms of number of packet storage) of the MAC layer queues of each node equals to one, so that to be able to suppress the inability of controlling packet transmission from the MAC layer queue and to enforce the packet handling in the

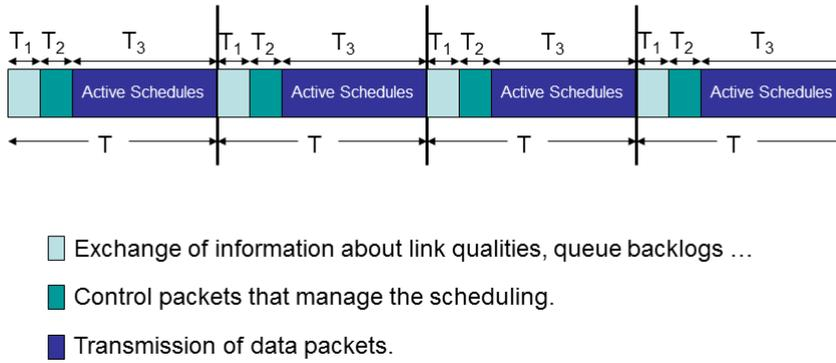

Figure 20: TDMA frame for the cooperative diamond network.

Sublayer 2.5 where we have full controllability by exploiting the features of Click.

4.5.4 Algorithm Implementation

The implementation of the *maximum-throughput* scheduling policy by designing a system architecture that enables parallel transmission in the diamond network, is given. This system architecture exploits the advanced features for packet handling of the Click Modular Router and the ath9k driver [2]. A significant point is that we use the ETT value [53] in order to acquire transmission rate estimation. The system design for the control and the network status collection can be *transparently* applied to each policy (either *throughput maximization* or *power minimization*). The only difference lies on the actual rule activation to achieve the different objectives as given by the policies stemmed from the solution of the Lyapunov optimization problem. Let us recall the TDMA access scheme described in the previous paragraph and explain the execution steps in each period:

T_1 Period, Relays report to the source S the length of their queue size and the *ETT* value of each link where they belong. ETT is the expected transmission time that is used as a metric to capture the link quality and to estimate all link states. ETT metrics are enabled and gathered by using Click and its value is given by the following formula: $ETT = \frac{1}{d_f d_r} \frac{B}{L}$, where d_f and d_r is expected forward and reverse link delivery probabilities (product of these two is the probability of a successful acknowledged transmission), B is the bandwidth and L the packet data size.

T₂ Period, The source S has already gathered the required information (queue sizes and the ETT metrics) in the previous period T₁. The source node calculates the maximum throughput policy by evaluating

$$\Delta Q_{SR_1}(t) \frac{1}{ETT_{SR_1}(t)} + Q_{R_2}(t) \frac{1}{ETT_{R_2D}(t)} < \Delta Q_{SR_2}(t) \frac{1}{ETT_{SR_2}(t)} + Q_{R_1}(t) \frac{1}{ETT_{R_1D}(t)}.$$

If the aforementioned condition is true then controller sets $a(t) = 0$ and this scheduling decision is sent to relays from the source node by broadcasting a control message reporting that the active schedules for the next time slot will be SR₂ and R₁D. Otherwise, controller sets $a(t) = 1$ and source broadcasts a control message to relays denoting the active schedules for the next time slot to be SR₁ and R₂D.

T₃ Period, Selected schedules are activated and packet transmissions are enabled according to the TDMA scheme. Per packet rate and power configuration is enabled through tweaking the Radiotap header [94]. Each packet, upon the scheduling transmission decision is configured with the appropriate power and rate level. Those values are the system parameters used for by the activation rule to produce the optimal scheduling/relay selection decision.

4.6 CLICK AND WIRELESS DRIVER IMPLEMENTATION

In this section, we present the efforts towards the implementation of a queue stable scheduling algorithm that exploits cooperative transmissions and the potential of centralized scheduling under the aid of a TDMA access scheme, in order to forward traffic from source to destination through relays. The implementation details of this scheme are transparent to the problem formulation objectives (*throughput-maximization* or *power minimization*) and illustrate the blue-prints of the control and the forwarding mechanisms in a Wi-Fi operated networks under a TDMA access scheme.

4.6.1 The User-level Cooperative Relaying Click Router (CRCR)

The Cooperative Relaying Click Router (CRCR) architecture is illustrated in Fig. 22 and Fig. 23. Fig. 22 shows the click architecture for the source and destination nodes while Fig. 23 shows the Click [72] architecture implementation for the two relays. Both of these schemes represent the packet processing flow and each element in the graph acts in an event driven way, where the existence

of an event triggers an operation. Inputs and outputs of these elements represent the incoming and outgoing packet flows. We have to clarify that for each incoming packet on any Click element, there is no rule to restrict that the same packet needs to be forwarded or modified (or not), to one of the output gates (or more than one) of this element, or even to be discarded. Particularly, when a packet arrives at an element it can be either consumed, by upper or lower OSI layers, or can be forwarded to other processing elements.

As mentioned previously, relays are featured with two wireless interfaces and packet processing and handling differs from the simple transmission or simple reception case, as source and destination nodes perform. For that reason, a forwarding mechanism is implemented inside Click modular router to support relaying capabilities. However, both schemes feature common packet processing blocks that aid in acquiring useful network statistics making use of an underlying probing mechanism (*ETTStat*) that estimates the ETT (Expected Transmission Time) [53] weights of the network links, while it features an additional probing mechanism (*DiamondStat*) for broadcasting commodity backlogs of each node to its neighbors (Moreover, the *DiamondStat* element in case of power minimization objective, is used to carry information about power consumption). Another element is the *SimpleQueue* that stores control packets which maintains useful information retrieved from the previous elements *ETTStat* and *DiamondStat*. Moreover, one prominent feature of the cooperative relaying router configuration, is the structure that stores the data packets. This element is the *DiamondQueue* that is not only responsible for storing data packets but it is also enhanced with the ability of setting the next receiver of the stored packets, defining the routing flow.

The source-destination architecture (Fig. 22) shares a lot of similarities with the well-known Roofnet architecture [37], while the main differentiation between them is the adoption of the *DiamondStat* extra probing mechanism and the replacement of the Roofnet data packet storage queue with the enhanced *DiamondQueue*. Moreover, the architecture of the relays (Fig. 23) is somehow more complicated in order to support the utilization of the two wireless interfaces. Next we describe the way that a packet is being processed from the very beginning when it is generated in an application layer process at the source node S and it is finally received by the destination node D.

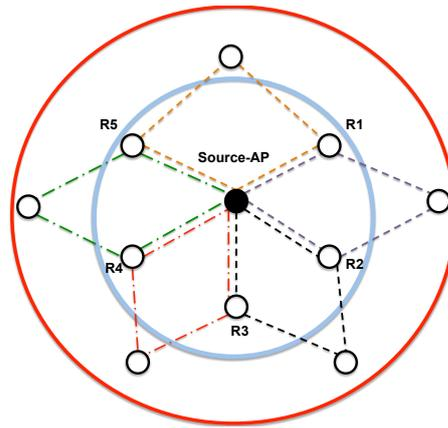

Figure 21: The solid red circle indicates the extended transmission coverage range in a WLAN. Wireless nodes belonging on a WLAN act as forwarders, forming canonical diamonds to assist networking when conditions are insufficient to benefit direct transmission on the cell-edge nodes. Each diamond can be activated i.e., in a round-robin way, one by one, for avoiding extra collisions.

4.6.2 Packet Forwarding Flow from Source to Destination (T_3 interval)

An application (i.e. *Iperf*) on the source node S generates some data packets that need to be transmitted to a final destination D . We explain how this operation is achieved and we explain packet processing that takes place on T_3 interval of the TDMA frame structure. Let us firstly focus on Fig. 22. The *Pseudo-Interface* element implements a TUN/TAP mechanism (virtual network layer/virtual link layer devices, used for routing and creating network bridge, respectively) that is able to both receive and transmit packets from upper layers. Now, the *Pseudo-Interface* receives those data packets coming from the upper layer and forwards them to the next processing element called *DiamondQueue* that stores those packets until an event triggers a packet request process. This event reflects an opportunity for transmission in the air when the environment is clear. The corresponding process activates the *Wireless-Interface* processing element, in order to retrieve the packets stored on the *DiamondQueue* element. Moreover, the *DiamondQueue* element changes the next receiver of the packet to be either the relay R_1 or relay R_2 , according to a calculated metric that can be based on either *Throughput-Maximization* or *Power-Minimization* objectives. (We clarify the details for the scheduling decision over packet control on the next sub-Section 4.6.3: *Enabling control actions for scheduling*). Then, the *DiamondQueue* element forwards the data packet to the next element named *PrioSched* which subsequently forwards it to the *Wireless-Interface* element, that it will finally transmit those packets over the air. The *PrioSched* element, how-

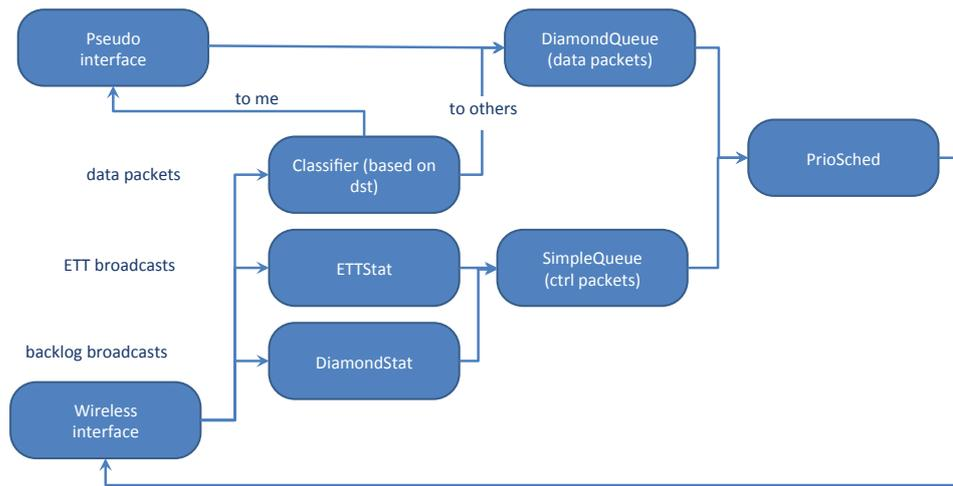

Figure 22: CRCR Architecture in Source/Destination: Click elements are interconnected so that to enable relaying support and packet forwarding.

ever receives also packets from another element called *SimpleQueue* that stores control information. So the main role of *PrioSched* is to choose the packets to be delivered on the *Wireless-Interface* element by giving first priority on the control packets rather than the data packets. When a packet finally ends on the *Wireless-Interface* it is transmitted over the air.

Now let us focus on Fig. 23, the relay node (either R_1 or R_2) uses the *Wireless-Interface* (that is configured to operate on Channel A) to listen to the air and receives some incoming data packets from the source node S. The packet discrimination whether are characterized either as data or control relying on their content takes place. Then the data packets are forwarded to the next processing element called *Classifier*. This element's role is to classify packets relying on the delivery destination of each data packet. Keep in mind that the data packets come from the source node S and need to be sent to the final destination D. So, due to the fact that the next destination of a data packet is not the relay node itself, the packet is forwarded to the *DiamondQueue B* (Channel B), that is a network layer queue that stores the incoming data packets that will be finally forwarded to the *Wireless-Interface B* (that listens to Channel B) through the *PrioSched B* element. *PrioSched* on relay nodes follow the same philosophy as in source node by prioritizing the packets delivery service to the *Wireless-Interface*. Actually, the rules that were described for the source node Click architecture in Fig. 22, about the *PrioSched* element, are the same rules regulate the operation of the *PrioSched* element lying on the relay nodes in Fig. 23. In sequence, when there will be a transmission opportunity, and the environment will be clear, the

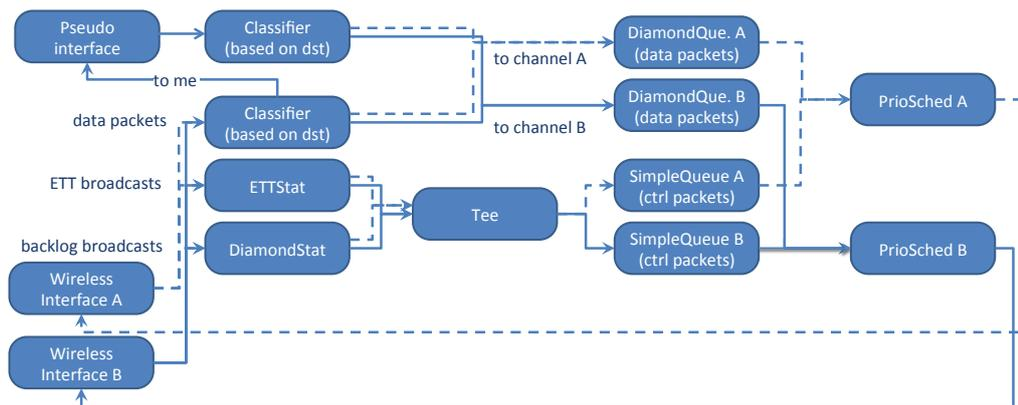

Figure 23: CRCR Architecture in Relays: Click elements are interconnected so that to enable relaying support and packet forwarding.

Wireless-Interface B (Channel B) will start to transmit forwarding packets over the air to the final destination D.

Now, let us focus on Fig. 22 again. Recall that destination D shares the same architecture of the cooperative relaying router as the source node S. Destination D, receives data packets coming from a relay node by using the *Wireless-Interface* element. Then data packets are being differentiated from other packet types (i.e control packets) and then they are being forwarded to the next processing element called *Classifier*. The *Classifier* element, classifies the data packets according to their final destination, and since the final destination is the node D, data packets are forwarded to the *Pseudo-Interface* element, that is responsible to store the packets and keeps them until an application process from an upper layer retrieves them.

4.6.3 Enabling Control Actions for Scheduling (T_1 and T_2 intervals)

In the previous paragraphs, we described the forwarding mechanism that uses relay nodes to aid in conveying the data traffic (T_3 interval on the TDMA frame structure). However, in order to enable certain rules for *Power-Minimization* or *Throughput-Maximization* as were given in Section 4.4, a mechanism that will enable sophisticated scheduling decisions should be enabled taking place on the T_1 and T_2 intervals of the TDMA frame structure. For that reason, we make use of control data that keep information about link statistics, queue backlogs,

power consumption and control actions for scheduling decisions. Source node S gathers this information (regarding data queue backlogs, power consumption and ETT links statistics) in order to calculate the next scheduling decision according to the implemented rule (Throughput-Maximization or Power-Minimization). Then it transmits the scheduling decision to the relay nodes, in accordance to the feasible scheduling action sets as they were defined previously and shown in Fig. 16.

Now let us focus on Fig. 22 again and suppose that the source node S receives through its *Wireless-Interface* element packets that are not data. Those packets can be either ETT statistics from the two relays or backlogs of the *DiamondQueues* that relays maintain. This information is collected on the source node and the metric for the next scheduling action is calculated. Then this metric is incorporated inside the packets of *DiamondStat*, those packets are sent periodically through the path (*SimpleQueue* \rightarrow *PrioSched* \rightarrow *Wireless-Interface*) to the relay nodes in order to denote the one relay node that should transmit and the other one that should receive, thus enforcing a half-duplex transmission constraint. In this way, relay nodes after receiving that broadcast packet that indicates to them explicitly what they should act in the forthcoming slot, are able to synchronize their actions and be compliant according to the feasible schedules. Moreover, another operation that *ETTStat* element is responsible for, on the source node S , is to gather information for the outgoing links. In addition, the *DiamondStat* element is responsible for the update of the information kept, with the accurate size of data backlogs on the source node S *DiamondQueue*.

In Fig. 23, focusing again on relay nodes, the *ETTStat* and *DiamondStat* elements collect statistics about relay node's outgoing links and update the information for the queue size of *DiamondData* element, respectively. Those statistics and information is being encapsulated on IP layer packets and then are duplicated through *Tee* element in order for those packets to be forwarded by both *Wireless-Interfaces*. This is done in order to enable exchange of information regarding data queue backlogs and link statistics among nodes.

4.6.4 Modifying the Radiotap Header to Support per Packet Power & Rate Configuration

In order to exploit the potential of cooperative relaying, it is essential to enable a *per-packet* configuration for power and rate control. By having the ability to configure the packet transmission characteristics, we can adapt to the

dynamic wireless communication conditions (i.e possible intermissions or fluctuations on the link quality). The need for mitigating such a fickleness as well as provisioning a design for a robust and stable cooperative communication network, that can adapt rapidly, is critical for the networking performance and the system's efficiency.

For that reason, we exploit the Radiotap Header [94], a mechanism that is used to supply additional information about packet frame transmission, considering the cross-layer flows, from the driver to userspace applications, and from userspace applications to the driver. This mechanism contains several fields where configurations about RX/TX antennas, the TX/RX frequency (Channel) in MHz, the TX/RX data rate and the transmit TX power (expressed in dBm) are described. Moreover, the Radiotap Header mechanism offers the flexibility of inserting additional fields to the end of the header without breaking ties for existing wireless driver parsers.

We continue with the packet configuration process next. In the transmission path, userspace applications define optionally the desired values of the fields in interest which are then parsed by the driver and used in order to complete the transmission of a packet according to the specified (hardware, region, standard compliance) settings. On the opposite side, in the reception path, for each packet received, the driver encapsulates a radiotap header filled with information about the reception before passing it to the userspace application.

For the needs of our implementation we took advantage of the following fields **a) Rate** and **b) TX power** (dBm) power, in order to transmit each packet with the appropriate values of rate and transmit power according to the *Throughput-Maximization* or *Power-Minimization* rule. For each packet, Click Modular Router fills the radiotap header with the values obtained from the algorithms and then Click Modular Router encapsulates the header in the packet before passing it to the driver for transmission. The driver parses the radiotap header to obtain the rate and transmit power values and then it strips off the packet before transmitting it. It is worth to mention here that Click router is an application layer daemon, that actually intercepts and injects packets with the use of *libpcap* library [106].

In order to enhance ath9k driver performing on *per-packet* basis configuration, we activated the corresponding identifiers for the two options mentioned earlier: Rate and TX power (dBm). Particularly, we enabled the supported mechanism to be able to identify that configuration by reading those options and to

apply the new settings on the hardware. In the Listing 1 we quote the changes applied for the Radiotap header to activate that functionality under the “*compat-wireless/net/mac80211/tx.c*” file in the ath9k driver[2].

Listing 1: Radiotap Header.

```

...
case IEEE80211_RADIOTAP_RATE:
    bitrate=(*iterator.this_arg)*5;
    for (i=0; <sband->n_bitrates; i++) {
        if (sband->bitrates[i].bitrate==bitrate)
            break;
    }
    if (i!=sband->n_bitrates)
        info->control.rates[0].idx = i;
        break;
case IEEE80211_RADIOTAP_DBM_TX_POWER:
    tx->local->user_power_level=*iterator.this_arg;
    ieee80211_hw_config(tx->local, 0);
    break;
...

```

Moreover, in order to validate that packets were transmitted with the correct configured values of transmission power and rate that we set, we acted twofold: 1st) For each succesful received packet in the destination node, we decapsulate the radiotap header and we read the actual values on the rate and power fields. 2nd) We used the Whireshark tool [111], an open-source packet analyzer, that was hosted by another wireless node (a non-participatnt node outside of the cooperative network but close to its vicinity) . We chose to set it up in another NITOS node close to the vicinity of the cooperative network, in order capture cooperative network’s transmitting live data and display the format and the corresponding rate and power transmission values.

4.7 EXPERIMENTAL RESULTS

For the performance evaluation of the proposed policies aiming at maximizing throughput efficiency and minimizing the total power consumption, we conducted 3 different experimentation setups relying on ath9k Wi-Fi driver [2] implementation, Radiotap header [94] enhancement and the Click Modular Router [72] exploitation, to achieve *per-packet* scheduling and control. We used

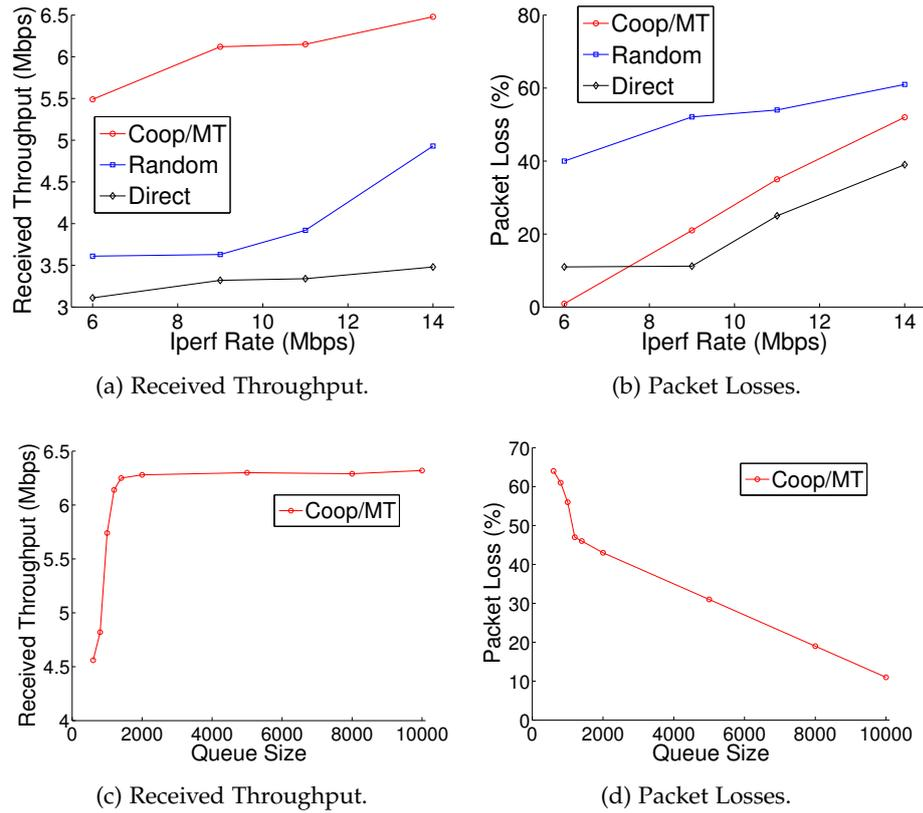

Figure 24: **1st Experiment:** (a) Received Throughput at Node D and (b) Packet Losses for Different Values of *Iperf* for Coop/MT, Random and Direct Transmission Policies, (b) Packet Losses for Different Values of *Iperf* for Coop/MT, Random and Direct Transmission Policies, **2nd Experiment:** (c) Received Throughput and (d) Packet Loss in Coop/MT Policy, for Different Values of Network-Layer (Click Buffer) Queue Size.

NITOS [13] testbed facility, located in the University of Thessaly campus in order to select a valid setup for the diamond network topology and to perform the experiments. In the 1st experiment setup, we compare the received throughput and the packet losses of the cooperative *maximum-throughput* (Coop/MT) policy with two different algorithms implementing a *random* selection scheduling policy and a *direct* scheduling policy, respectively. We show that in both cases the Coop/MT policy outperforms achieving better throughput results rather than the other two policies. In the 2nd experiment setup, we evaluated the received throughput performance for the Coop/MT policy when we tuned the maximum length of *buffer* size in the network-layer *queue* on the Click Modular Router, where incoming packets are stored. In the 3^d experiment setup, we measured the efficiency of the power minimization rule at a cost of the induced delay caused by equalizing the *V* parameter, achieving also a delay-

performance tradeoff. Moreover, in all setups we keep the MAC layer queue size equals to 1 (one), as a means to enforce the suppression of CSMA protocol and to avoid undesirable collisions.

4.7.1 1st Experiment

In this experiment, we compare the performance of maximum-throughput policy against the direct transmission policy and a random selection scheduling policy. We configured the links on the first hop (second hop) to operate on channel 100 (140) respectively, in IEEE 802.11a mode. For a static configuration of the PHY rate that was set on 9 Mbps, we collected measurements regarding the received throughput, when we injected application traffic (UDP traffic with retransmissions disabled) on different rates (6, 9, 11 and 14 Mbps) by using *Iperf* tool. Moreover, for the same experimentation setup, we collected the packet losses as we kept the PHY rate constant at 9 Mbps, and changed the *Iperf* rate. The TDMA access scheme period was set on 100 ms, and each experiment session last for 1 min. We repeated this experiment 10 times to take average values.

Experimental Inference: We observe that the achieved throughput efficiency of the Coop/MT policy is better comparing to the efficiency of the random relay selection policy and the direct transmission from the source S to destination D for different values of the *Iperf* rate. Specifically, in the direct transmission scenario from source S to destination D, we selected an experimentation setup of rich interference where nearby wireless networks were configured to operate on the same frequency/channel as the source/destination pair in the diamond network. So we assumed a setup, where direct transmission does not benefit throughput efficiency. Results collected are reported in the Table 3 and also illustrated in Fig. 24.a. For the packet losses, we observed that when we injected higher application rate in the *Iperf*, we received higher packet losses. This is expected, since the PHY rate configured on 9 Mbps acts as a bottleneck, when we use higher application *Iperf* rates, causing higher packet drops and losses. Packet losses on cooperative maximum-throughput (Coop/MT) are lower comparing to packet losses on random relay selection policy, and this justifies the performance efficiency of the Coop/MT scheduling policy. Table 4 summarizes the packet loss results, while Fig. 24.b shows a graphical representation. The lower percentages of packet losses when we use direct transmission is explained by the fact that in the case of Coop/MT and random selection poli-

cies, we employed the TDMA framework built in Click [72] for packet control-ability and forwarding that injects extra synchronization overhead and latency. However, in the case of direct transmission this framework is missing.

4.7.2 2nd Experiment

In this experiment setup, we observe the impact of the buffer queue size on the throughput performance and the packet losses in the implemented cooperative *maximum-throughput* (Coop/MT) policy. For that reason, we keep constant the PHY rate at 9 Mbps, and the *Iperf* rate at 14 Mbps and we collected the received throughput at the destination node D and the packet losses for different sizes of the network-layer queue maintained in the Click implementation. Testing sessions were performed for buffer queue size spanning from 600 packets to 10000 packets capacity size. Each experiment session duration was set to 1 min. We repeated also this experiment 10 times to take average values. Results collected are reported in the Table 5 and also illustrated in Fig. 24.c and 24.d

Experimental Inference: We observe a significant rise in throughput as the queue length size increases (up to a critical point) while also at the same time the packet loss percentage drops. This behavior is expected due to fact that the more the queuing capacity storage availability, the more the capability of receiving higher amounts of traffic is satisfied, having impact in higher throughput and lower packet drops. After the critical point, despite the increase in the buffer queue size the received throughput is saturated since the buffer queue size does not affect the throughput performance any more, however packet loss

Table 3: Received Throughput at Node D for Different Values of *Iperf* for Coop/MT, Random and Direct Transmission Policies.

<i>Iperf</i> Rate (Mbps)	<i>Received Throughput</i> (Mbps)		
	<i>Coop/MT</i>	<i>Random</i>	<i>Direct</i>
6	5.49	3.61	3.11
9	6.12	3.63	3.32
11	6.15	3.92	3.34
14	6.48	4.93	3.48

percentage drops significantly down, since larger buffer capacity storage aids in improved maintenance and robust packet transmissions.

4.7.3 3rd Experiment

In this experiment setup we seek to investigate the congestion (induced delay) - power performance *tradeoff* by measuring the total average queue sizes and the total average power consumption, for different values of V parameter. The larger the V value the more the network controller selects more power efficient schedules and that results in important power consumption reduction with a cost of obtaining large increment in queue sizes. On the other hand, for small values of V the network controller chooses scheduling decisions that will keep queues size low but with a sufficient cost in the power consumption levels. Results collected are reported in the Table 6 and also illustrated in Fig. 25. Fig. 25.a shows the total average power consumption achieved for different values of V and Fig. 25.b shows the respective total average queue sizes.

In order to estimate for the (ab) link, the channel condition ($S_{ab}(t)$), we arbitrarily quantize the received ETT metric into three levels, thus representing three discrete states that a link quality can be characterized of. Namely, *Good*, *Medium* or *Bad* quality. The quantization levels were chosen after measurement experimentation on the particular diamond topology chosen in the NITOS [13] testbed facility and by making use of the NITOS connectivity tool C.[10], D.[3], an online web tool for link connectivity assessment. Then, we defined the respective power ($P_{ab}(t)$) transmission levels, over a link, depending on the link

Table 4: Packet Losses for Different Values of *Iperf* for Coop/MT, Random and Direct Transmission Policies.

<i>Iperf</i> Rate (Mbps)	Packet Loss (%)		
	<i>Coop/MT</i>	<i>Random</i>	<i>Direct</i>
6	0.9%	40%	11%
9	21%	52.1%	11.2%
11	35%	54%	25%
14	62%	61%	39%

Table 5: Received Throughput & Packet Loss in Coop/MT Policy, for Different Values of Network-Layer (Click Buffer) Queue Size.

<i>Queue Size</i>	<i>Received Throughput (Mbps)</i>	<i>Packet Loss (%)</i>
600	4.56	64%
800	4.82	61%
1000	5.74	56%
1200	6.14	47%
1400	6.25	46%
2000	6.28	43%
5000	6.3	31%
8000	6.29	19%
10000	6.32	11%

quality quantization scheme that was estimated before with the use of ETT metric. More specifically, the power needed for the transmission in a *Good* link was $P^{Good} = 3$ dBm, on an *Medium* link was $P^{Medium} = 9$ dBm and on a *Bad* link was $P^{Bad} = 15$ dBm. Results shown are translated in Watts relying in the following formula: $P_{(mW)} = 10^{(P_{dBm}/10)}$.

We configured the links on the first hop (second hop) to operate on channel 100 (140) respectively, in IEEE 802.11a mode. The PHY rate was set at 9 Mbps and we injected application traffic on a rate of 14 Mbps by using the iperf tool. The network-layer queue size on the Click Modular Router was set at 10000 packets. We set the parameter V at five different values (2, 10, 100, 1000 and 10000) and measured the average total power consumption and the average queue length. The TDMA access scheme period was set on 100 ms, and each experiment session last for 1 min. We repeated this experiment 10 times to take average values.

For each experiment, total average value for power consumption \bar{P} and queue size \bar{Q} are estimated by the following formulas: $\bar{P}_{avg}(t+1) = \frac{t}{t+1}\bar{P}_{avg}(t) + \frac{1}{t+1}\sum_i P_i(t)$ and $\bar{Q}_{avg}(t+1) = \frac{t}{t+1}\bar{Q}_{avg}(t) + \frac{1}{t+1}\sum_i Q_i(t)$, where for the TDMA time slot t on each transmitting node $i \in \{S, R_1, R_2\}$, the $P_i(t)$ and $Q_i(t)$ represent the measured power consumptions and the queue sizes in buffers, respectively.

Experimental Inference: We observe that parameter V can be used to calibrate delay and performance efficiency in the intermediate regime $0 < V < +\infty$. The higher the value of V parameter chosen, the network controller tends to select power-efficient schedules. This has impact on end-to-end delay, as V grows, queue backlogs also increase in load and, hence buffer congestion. So, the performance-delay *tradeoff* is attained as follows:

- Higher V (\nearrow) results in less power consumption (\searrow), but larger end-to-end delay (\nearrow).
- Smaller V (\searrow) results in higher power consumption (\nearrow), and less end-to-end delay (\searrow).

4.8 CONCLUSION

In this work, we presented an implementation design for a TDMA protocol about optimal relay selection and scheduling in cooperative diamond topologies for infrastructure-less wireless networks. The significant merit of this work is the exploitation of the potential of centralized scheduling through TDMA to achieve optimal performance efficiency. We elaborated a network controller within the TDMA frame to enforce policies getting inspired by the Lyapunov-drift optimization methodology. In our formulation, we considered the class of scheduling policies that select concurrently a non-interfering subset of links. We sought to attain particular performance-delay tradeoffs in our system design.

Our implementation was based on modifying the ath9k [2] wireless driver and the radiotap header functionality[94] as well as on exploiting the features of Click Router [72]. Our architecture design is backwards compatible on commercial Wi-Fi products and not limited in the presence of the CSMA protocol. Results collected through testbed experimentation in the NITOS facility revealed improvement in performance per objective when our relay selection scheme was applied. Although, our work was implemented and evaluated for infrastructure-less cooperative wireless networks, a significant merit of this design is the ability to leverage the optimal centralized scheduling in infrastructure (cellular) wireless networks, such as the emerging 4G-LTE which employs TDMA as an access scheme and supports relay assisted transmissions in its design primitives. Therefore, as a future plan we intend to implement this TDMA scheme for optimal relay selection and scheduling in 4G-LTE networks.

Table 6: Measured Total Time Average Power Consumption (Watt) & Time Average Value of (Click Buffer) Queue Size.

V	<i>Avg. Power (Watt)</i>	<i>Avg. Queue Size</i>
2	0.003608	2269
10	0.002315	2457
100	0.002233	2611
1000	0.002129	2798
10000	0.001835	2853

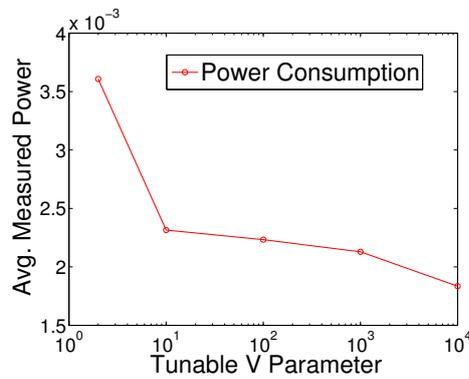
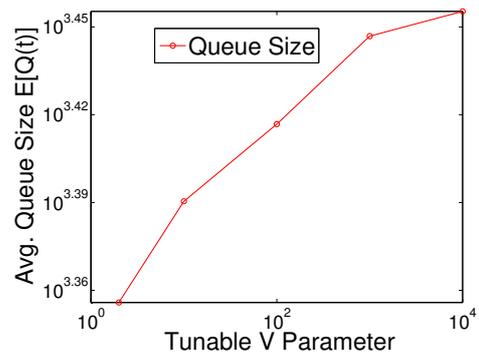
(a) Power Consumption (Watts) vs. V .(b) Queue Size vs. V .Figure 25: 3rd Experiment: Power minimization, (a) Total average power consumption and (b) Total average queue size vs. V parameter.

TOWARDS EVOLVED USER EQUIPMENT FOR 5G SYSTEMS: LTE-A COOPERATIVE NETWORKING

As the roll-out of 4G technology is on track, the plans for 5G have substantially ascended the ambitions for high quality broadband experience and promise to meet the increasing demand for high throughput and low latency services by end users. Moreover, the recent trend in LTE deployments that considers heterogeneous and small cells in harsh, dense and mobilized environments indicates the importance to deliver effective and evolved solutions as enablers for end-to-end services. To this end, this chapter discusses a potential evolution of LTE that employs user equipments (UE) as an active element of the network, in order to enable new use-cases. The proposed architecture leverages the legacy UE and extends its capabilities to operate simultaneously over multiple base stations (eNBs). Therefore, an evolved-UE (eUE) is introduced to enable reliable multi-hop operation through cooperative relaying and to achieve low latency communication through L2/MAC forwarding. The arising benefits are twofold: *i*) From the network perspective, eUEs extend its operation and restore the point-to-point X2 air-interface through virtual links so as to reestablish the inter-eNB communication, and *ii*) for the eUE, the new architecture provides multiple data pipes through collaborative radio bearers so as to increase capacity.

Keywords – evolved UEs, Wireless Mesh, LTE-A.

Related Published Work:

- C.[1] Apostolos Apostolaras, Navid Nikaein, Raymond Knopp, Thanasis Korakis, Iordanis Koutsopoulos and Leandros Tassiulas. “*Evolving UEs for L2 Collaborative Packet Forwarding.*” submitted in ACM Conference on emerging Networking EXperiments and Technologies, CoNEXT 2014

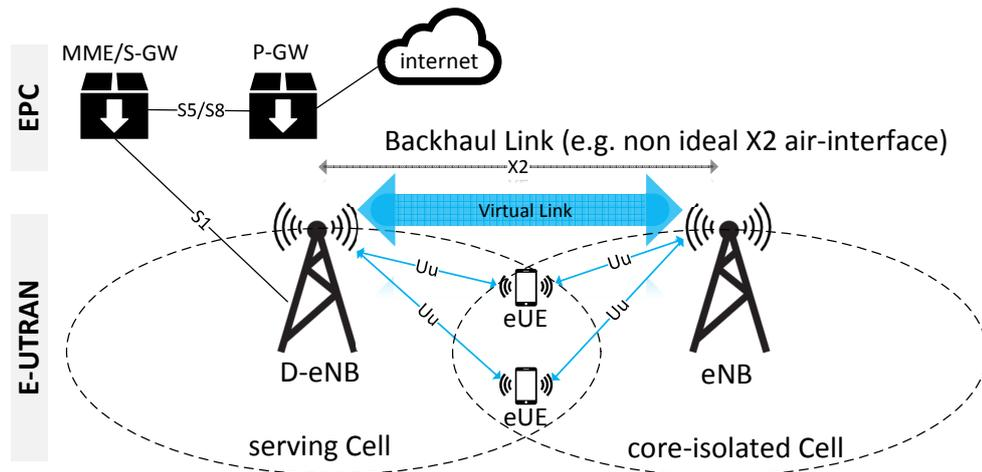

Figure 26: Evolving the future Radio Access Networks (RANs): Evolved UEs (eUEs) are leveraged to become active network elements, providing backhaul access to core-isolated cells and realizing diverse communication paths.

5.1 INTRODUCTION

In a race against time to meet the stringent requirements for satisfying the unprecedented growth on mobile data traffic, both industry and operators strive at fierce competition within research and development for delivering novel and disruptive solutions on the promise of future (5G) networks. Providing such solutions that can offer tangible results for low latency and increased throughput communication has been in the keen interest and diligent activity among researchers so as to tackle the challenge of inadequate capacity.

Contrary to the prior generations of cellular networks' technology (2G, 3G), the recent 4G technologies (LTE-A Rel. 11 & Rel. 12), have raised the ambitions substantially for enabling reliable, rapid and ubiquitous communications in a flat all IP architecture. In recent years, the wireless broadband community has witnessed a growing expansion of the newest generation (4G) wireless network deployments. The proliferation of 4G deployments has been increasing worldwide, promising to offer to carriers the capabilities to keep up with the increasing traffic growth. However, on the opposite side the number of mobile users with data-hungry (resource intensive) devices, has been exploded exponentially attaining almost the cellular networks' capacity capabilities. Cisco and Qualcomm forecasts for traffic explosion are indicative of this stern situation [64, 92].

Moreover, the requirements for 5G technology that have been partially defined, render new communication trends for seamless connectivity, heteroge-

neous networking and interoperability highly attractive [27, 49]. Those trends stipulate a combination of sophisticated techniques that have been in the foreground research promising to be the key enablers for facing the aforementioned intimidating challenge of increasing traffic. Small cell and heterogeneous network deployments, data offloading techniques, tighter 4G/WiFi interworking, advanced interference coordination techniques and spectrum management, coordinated multipoint (CoMP) transmissions, relaying and multi-flow techniques across small cells are the most promising solutions to offer improved networking if both enabled and combined successfully. Despite their promising benefits, all the above techniques require a network infrastructure that can simultaneously provide lower costs, lower latency, and greater flexibility.

In this Chapter, we propose a new paradigm for L2/MAC information transfer, enabled by information forwarding that is performed by evolved UEs (eUEs). Our approach promotes a clear trend to rethink and redesign what is perceived today as wireless end-to-end information transfer. Theoretical discussions in that respect about future and upcoming advances for next generation wireless networks more akin to a “*flatter*” network architecture, are quickly developing now. The major finding is the exploitation of a new virtual air-interface for next generation radio access network (RAN) systems that extends the classical point-to-point information transfer and enables new use-cases. We re-establish the X2-air interface to accommodate a new mobile wireless access paradigm of low latency communication where two eNBs exploit intermediate mobile eUEs to interconnect and exchange data. Therefore, a virtual air-interface is being established between two eNBs with the aid of collaborative eUEs. Yet, existing techniques are expressed only at a 3GPP legacy in-band/out-band relaying level [112, 107]. Although state-of-the-art results for relaying and data forwarding have exhibited the feasibility of such approaches, their disadvantage is that relays are used to serve UEs exclusively, terminate all the S1-AP protocol and signaling passes through their S-GW and MME [19]. This means that relays must maintain sufficient backhaul access to the core to be operational.

We illustrate our envision in Fig. 26, where eUEs are leveraged to interconnect two eNBs. We claim that, our architecture if translated to realistic network coordination methods, can radically refine and disrupt the way that we organize resources and perform end-to-end information transfer in cellular networks. Nevertheless, the integration of such an architecture in cellular net-

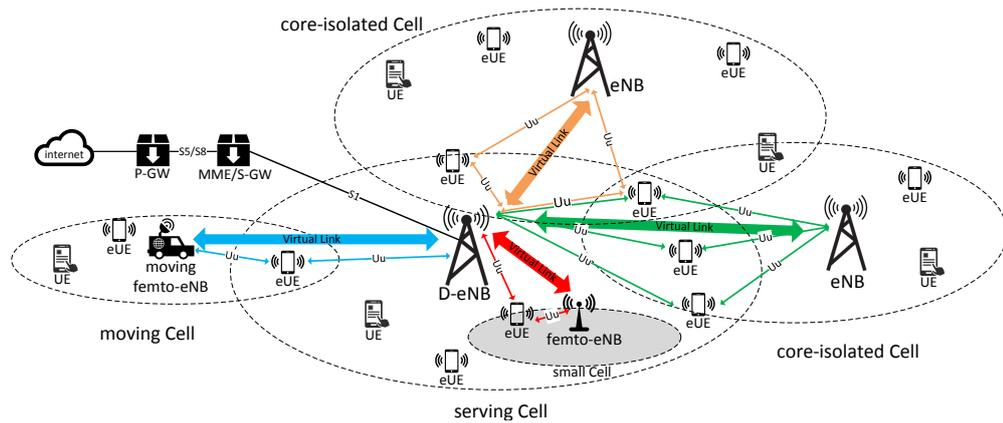

Figure 27: Network Topology: Moving, small and core-isolated cells exploit eUE-enabled multipoint connectivity to access backhaul, when either non-ideal X2-air interfaces cannot be effectively utilized to inter-connect eNBs or wired interfaces are infeasible or too costly to be deployed.

works introduces implementation and design challenges that we need to effectively come up with. Next, we present those that have been the main motives on the design of the proposed architecture and provide solutions to effectively address them.

5.1.1 Motivation and Scope of this Work

Our aim is to design a scalable, flexible and resilient architecture for supporting packet-level forwarding by leveraging and evolving legacy UEs to operate as active elements of the network, to forward the traffic and to provide backhaul access to moving and core-isolated eNBs.

Challenge 1: Evolve radio access network - Enable new use cases by exploiting greater flexibility and diversity. Evolving UEs for enabling new use-cases such as moving cells which are required by public safety and intelligent transport systems (ITS) applications is of paramount importance. In example as illustrated in Fig. 27, network coverage extension can be realized rapidly by taking advantage of the diverse and multiple paths that eUEs can potentially create in scenarios where network planning cannot be previously contemplated or designed. Moreover, core-isolated cells that miss wired/fiber connection to the core network or experience poor wireless connectivity to another eNB due to a non-ideal X2 air-interface, can be capable of accessing the core through the diverse paths created by users. In parallel multiple eNBs provide alternative paths for routing and service to users.

Challenge 2: Improve network capacity and provide low latency communications. The challenge of limited capacity can be tackled effectively by enabling multiple associations of an eUE to more than one eNBs so as to exploit inter-node radio resource aggregation or CoMP reception. Moreover, extending UEs capabilities with intelligent protocols and advanced RF processing so as to be able to forward packets within the network, can be advocate of wireless mesh networking over the cellular network. Packet forwarding involves advanced collaborative relaying performed by eUEs, that are used/enabled as a service by the eNBs [54]. We claim that a potential wireless mesh multi-hop operation introduces an extra communication overhead that if not carefully considered would increase delay and communication latency. Induced latency can be reduced by enabling advanced access techniques at the access layer, providing services locally to the clients, using adaptive modulation and coding (AMC) schemes, enabling packet-level forwarding at the MAC/L2 layer when a collaborative transmission is being identified and using of advanced buffer aware scheduling techniques.

Challenge 3: Design a both light-weight and cost-effective architecture that will enable mobile broadband operators to be competitive, from a price/performance perspective compared to wired networks for accessing the core: In this perspective, UEs cannot be passive listeners any more that filter out the signals coming from eNBs and keeping the content destined exclusively to them, while also dropping the rest information as noise. Therefore, in the proposed architecture UEs are evolved into *on-demand* intermediate data forwarders (called eUEs) that convey traffic among eNBs. From the one hand, at a cost of a more dynamic network and resources management, eNBs can leverage eUEs to assist them with cooperative forwarding so as to improve their performance. From the other hand, eUEs can realize alternative paths to the core network so as to experience improved throughput. Moreover, eUEs need strong incentives to participate in such traffic admission and as a consequence, a promising economical business model is introduced where operators compensate users for assisting them [61, 99]. This dual benefit is important for the operators as it provides a tangible solution to reduce CAPital EXPenditure (CAPEX) and OPERational EXPenditure (OPEX) costs by removing the need for infrastructure investments with legacy 3GPP relays and network re-planning. Moreover, operators will be capable of providing end-to-end services in isolated cells through the diverse routing paths that eUEs enable. In addition eUE can benefit from participating in such a collaboration acquiring fiscal gains upon agreement offered by the operators.

Contribution: In this Chapter, we discuss a disruptive architecture which elaborates evolved-UEs (eUEs) in the context of future cellular networks. A more intelligent user equipment is introduced, that is capable of associating with multiple eNBs. The intellectual merit of this concept can be realized twofold: *i)* In moving cell scenarios, eUEs extend the network coverage area by building virtual links (VL) to provide access to core-isolated eNBs located on public transport buses or dedicated public safety vehicles. The eUE functionalities are exploited by moving eNBs as a service for improving the network performance. *ii)* In small and/or densified cell scenarios, network and subsequently eNBs provide multiple connectivity and data pipes to the eUEs through different radio bearers so as to increase their capacity and provide seamless handover between the connected eNBs. Through cooperative relaying and L2/MAC forwarding, eUEs are utilized to provide *reliable* and *low-latency* communication and as a consequence they become enablers for wireless multi-hop networking among eNBs.

Organization structure: The rest of this Chapter is organized as follows: In Section 5.2 we describe representative use-cases that exploit eUE-aided L2 forwarding. In Section 5.3, we describe the design of the proposed architecture as an enabler of a wireless mesh operation over a cellular topology. Then, we give an overview of the procedures designed in PHY and MAC layer for enabling this architecture. Individual rationality and performance evaluation of our architecture are validated in Section 5.4. In sequence, related work is presented in Section 5.5 and Section 5.6 concludes our work.

5.2 EXPLORE FOR NEW USE CASES

5.2.1 *Moving Cells*

In public safety or intelligent transport system (ITS) scenarios, the planning of the point-to-point wireless interface for backhaul access may often be infeasible to be established between moving and/or static cells. Currently, in 3GPP an interface named X2 is used to allow meshing of neighboring eNBs so as to coordinate base stations and assist UEs' handover procedure.

Public Safety: When a major emergency situation such as an earthquake, wildfire, hurricane or warfare strikes communication networks related to civil or military purposes, need to be built rapidly and on-the-fly. That is the case

where first responders and military require immediate communications support to save lives, establish relief operations and provide ongoing assistance in affected communities. In such tactical response cases, providing backhaul access to a rapid network deployment can be effectively enabled by leveraging the respond commander terminals (UEs) to convey traffic.

Intelligent Transport Systems: In planned deployments for public transport, employing moving relay nodes in vehicles (buses, metro, trains, etc.) is a promising solution to overcome potential shortages like shadow fading that cause poor QoS and QoE to end-users [103]. Solutions stemming from heterogeneous and small cell networks, data relaying and offloading methods promise performance improvements and are quite attractive to immerse into future cellular networks[35].

However, what is missing is a light-weight and cost-effective solution for the unplanned deployments. Core-isolated eNBs of moving vehicles often fade away from the macro eNB's coverage range as they move out of the predefined trajectory which ensures communication. By exploiting the potential of eUEs to convey traffic within the network, operators can provide resilient backhaul access to the core for these moving cells. This solution comes also with zero cost for network planning and infrastructure deployment.

5.2.2 *Small Cells*

In a dense urban area, where large physical obstacles such as buildings create a harsh communication environment, coverage holes may often occur due to volatile ambient conditions, even when network planning had been contemplatively designed. Although, the solution of small cells can offer improved capacity and extended coverage to users, an UE may still experience poor performance, mainly at the cell edge or during handover, since it is only served by only one eNB regardless of the number of macro or small base stations in its vicinity, thus missing the actual diversity benefit.

In fact, carriers need a cost-effective, fast and resilient solution to offer to UEs efficient alternative paths for service which can fully exploit the available resources. By allowing eUEs to communicate with multiple eNBs realizing a CoMP, the benefit to users is clear. "The higher the number of active alternative paths from which a user can be actually served, the more the received throughput and the less the incurred latency."

5.3 ARCHITECTURE

Our architecture aims to support a flexible and resilient network topology by providing benefits both to eUEs and to eNBs. eUEs, by enabling multiple association to eNBs, can improve their throughput, as well as the handover experience by exploiting inter-node radio resource aggregation. U-plane data can be delivered to the eUE through multiple sources. For eNBs of core-isolated cells, having a plenty of intermediate assisting forwarders at their disposal, provides them with diverse routes for backhaul access when a non-ideal X2 wireless or wired backhaul connection for accessing the core is infeasible or too costly to be deployed. The above can be realized as a new coordinated multipoint (CoMP) concept, as it is realized by the eUEs forming a virtual MIMO antenna to transmit to the moving/core-isolated eNB.

5.3.1 LTE Mesh Network Overview

The network topology that we consider in this work, is a wireless mesh network that is built on the top of LTE. This topology is assumed to be 2-level hierarchical or clustered, where a cluster is defined as the set of nodes which are characterized by one-hop connectivity with the eNB macro base station. Fig. 27 illustrates the network topology and the new use-cases introduced by eUE-assisted packet forwarding. In this topology, there exist three type of nodes.

- **eNodeBs-(eNBs)** act as 3GPP base stations and they are responsible for *i)* the coordination of user traffic, *ii)* the management and scheduling of radio resources (i.e. time, frequency, and space) within a cell and *iii)* the routing for intra and inter cell communication. It should be considered that user traffic UE traffic is not necessarily passed to the core network through eNBs.
- **User Equipments-(UEs)** They are legacy 3GPP user equipment.
- **evolved User Equipments-(eUEs)** are actually evolved UEs with enhanced capabilities of associating to multiple eNBs and thus interconnecting adjacent eNBs. They act as 3GPP UE terminals maintaining their initial operation and also act as a slave with respect to the eNBs perspective. As UEs do, they also interpret the scheduling messages coming from eNBs on signaling channels so as to enable traffic routing and forwarding relying on the allocated physical resource blocks RBs. eUEs can be also used to extend the cell serving area and provide backhaul access to core-isolated eNBs. eUEs as

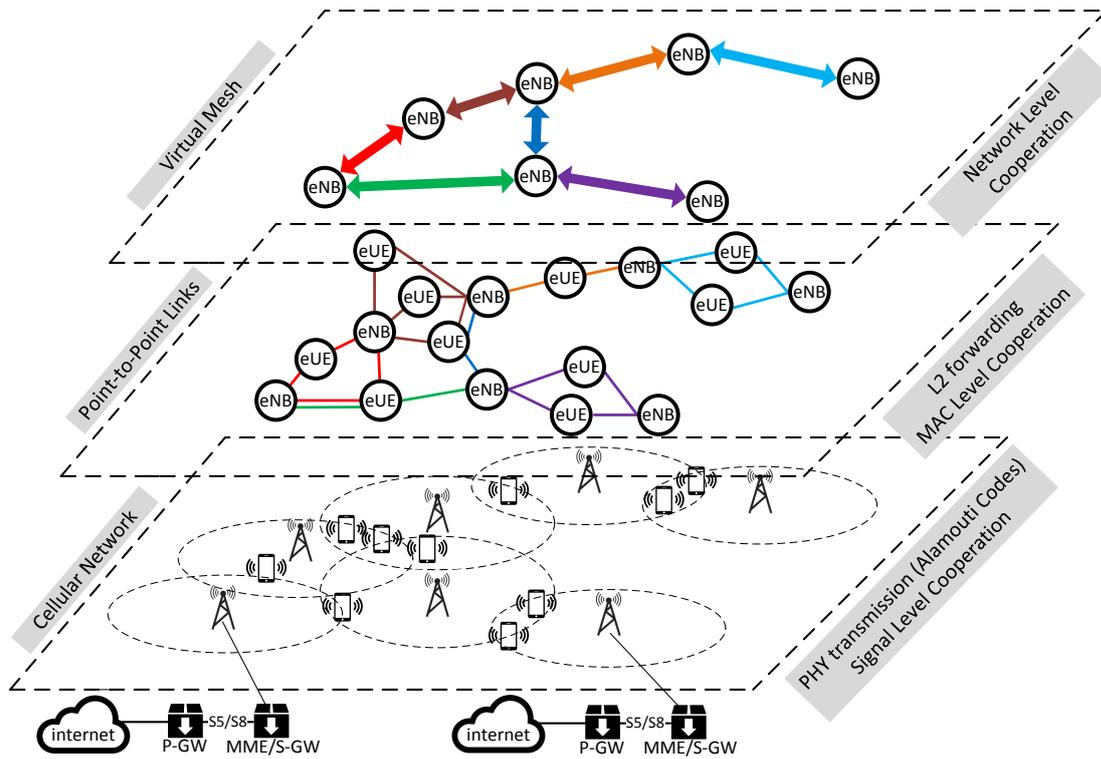

Figure 28: An Overlay Mesh Network of eNBs.

intermediate nodes are utilized so as to forward the traffic originating from or destined to eNBs. They belong on the control of the radio access network (RAN) of the bridged eNBs.

5.3.2 Virtual Overlay - Enable Mesh Networking

Consider this: In cellular networks, we have to deploy typically wires (fiber/copper) to base stations in order to access the core network and enable internet connectivity to the wireless access part. Although it is the standard method in LTE and LTE-A deployments to access an internet gateway, the proliferation of relays and small cells, although it promises to tackle this problem, it introduces additional costs both for the operators and the users. The former need to invest and the latter are called for buying new equipment (e.g. Home-eNBs). While in LTE the X2 air-interface can be utilized for interconnecting eNBs, it has been mainly formed for exchanging control plane information between eNBs for assisting handover procedures and advanced inter-cell interference coordination (ICIC) techniques. Contrary to the above, our networking approach rethinks the standard way of wireless cellular communication transfer. We design a network architecture that can enable a virtual overlay wireless mesh on the top of cellular topology that is abstracted by the eUEs collaboration. We claim that

for enabling the wireless meshing in large scale requires fundamentally advanced SDN (Software Defined Networking). Moreover, in order to establish a virtual link by appropriately selecting the subset of eUEs, it should be considered also the level of cooperation they are able or willing to provide to the network according to a Service-level-agreement (SLA). The selected eUEs list is then provided to the corresponding eNBs so as to initiate the establishment of a collaborative virtual link [61, 99]. That is out of the scope of this work and we mainly focus on the PHY and MAC operations for proving the individual rationality of this architecture. However, the significance of the above concept implicates the need to describe the hidden potential offered.

Fig. 28 illustrates the layered structure of a wireless mesh in a large scale. Nevertheless, a virtual link (VL) between two eNBs is composed of at least two consecutive point-to-point links with the assistance of one intermediate eUE. Multiple eUEs can collaboratively participate in the formation of one VL. Therefore a VL can be perceived into two phases: a broadcast point-to-multipoint (P2MP) phase from (source) eNB to eUEs and a cooperative multi-point-to-point (MP2P) phase from eUEs to (destination) eNB. The interaction among the layers that is dynamically enabled by the eUEs suggests a new type of collaborative transmission for cooperation that is realized as a CoMP in uplink where eUEs form a virtual MIMO antenna for transmitting to the destination eNB.

Particularly, this architecture implicates the PHY layer to present a VL as a link abstraction to the MAC layer with a given probability of packet erasure and subsequently the MAC layer to present a VL to the network layer as a means of enabling collaborative bearers for local traffic routing between eNBs and supporting end-to-end services.

- *Signal-level Cooperation* is operated by the PHY layer, which is responsible for identifying the optimal way to cooperate at the signal-level so that the bit error probability is minimized with respect to predefined quality constraints. Signal-level cooperation presents an interesting abstraction to higher layers: that is, a VL with a given probability of packet erasure. Moreover, cooperation at signal-level implicates all eUEs regardless of the perceived link quality in TX or RX mode with the interconnected eNBs. An appropriate selection of a relaying and coding scheme e.g. Decode-and-Forward (DF) or Quantize-Map-Forward (QMF) and distributed Alamouti codes allows for independent coordination among eUEs and indicates an over-the-air signal combination towards the destination eNB [54].

- *Packet-level Cooperation* is operated by the MAC, or more generally Layer 2 (L2), which is responsible for data-forwarding and packet scheduling. More specifically, L2 will create the virtual link by leveraging the legacy 3GPP connection establishment procedures in order to complete packet transmissions between two specific end-points. It will identify which physical links (PLs) and their respective end-points need to be activated so that end-to-end frame error rate is minimized, hence drastically improving the efficiency of the signal-level cooperation. The actual decision about VL establishment and PL activation is obtained by the higher layers and L2 from its side identifies and reports this induced relay selection to the higher layers. In addition, to regular scheduling MAC performs scheduling of collaborative broadcast in DL and CoMP transmission in UL. The routing path is optimized as packets do not have to traverse the whole protocol stack and when identified by the MAC they are forwarded for collaborative transmission. Reliable end-to-end packet delivery over a VL may be also handled by L2 through retransmission and/or forwarding-error-correction-codes (FEC), e.g. Hybrid-ARQ (HARQ).
- *Network-level Cooperation* The decision about local traffic routing and relay selection (control plane) over a VL can be performed either at the network or higher layers. This information is passed to the MAC. Therefore, there is a need to select one or a group of eUEs that will be used as relays to enable signal and packet level cooperation (data plane). Furthermore, the control plane and the data plane are decoupled as the routing decision and relay selection are performed at the higher layers while data forwarding at the MAC/PHY layer. Therefore, a sophisticated mechanism to support the cooperation by giving access to the forwarding table of the MAC is required and need to be enabled. Such a mechanism can be implemented either locally or over the network. In the former case, the MAC/L2 forwarding table can be simply built based on the routing table in a similar way as done in the L2.5/L3 forwarding in the multiprotocol label switching (MPLS). In the latter case, a software defined networking approach can be applied to interface between the control and data plane.

5.3.3 Procedures

PHY Layer Design.

Consider the following scenario where a source eNB intends to transmit to the destination eNB over a VL. The timing of scheduling messages and data

transmission adopt the standard procedures in legacy LTE. This end-to-end transmission is realized reciprocally over the two hops that constitute the VL in downlink and uplink direction. Thus, when the first hop is on downlink the second is on uplink.

Cell-search: Search procedures is the primary step to access the LTE network, and consists of a series of synchronization stages to determine time and frequency parameters required for correct timing in uplink and downlink. Standard LTE synchronization procedures allows a terminal to detect the primary and subsequently the secondary synchronization sequences (PSS, SSS) from at most 3 eNBs distinguished by their cell ID group (also known as physical layer identity) representing roots of the Zadoff-Chu sequences [17]. Using this property, the procedures by which an eUE is attached to the network could be activated for non-primary eNBs. The attachment procedure, that an eUE follows so as to associate with an eNB follows the standard 3GPP RRC connection reconfiguration process.

Synchronization: For core-isolated eNBs, over-the-air decentralized network synchronization can be utilized by allowing a designated (usually the *Donor* eNB) to provide a time reference synchronization within the network. Then, eUEs will propagate the signal to the core-isolated eNBs through a common synchronization channel. This approach also resolves the interference problem for scenarios with multiple transmitters and one receiver as all the core-isolated eNBs are synchronized with the same reference point and that the cyclic prefix is able to absorb the differential propagation delay. Regular UEs will follow the standard timing advance procedure controlled by their respective eNBs, while the eUEs will select one of the available timing advance value (e.g. the minimum value or that of communicating eNB). Note that this solution does not require any coordination, and scales smoothly with the number of connected eUEs. However, if the reliability of a unique reference point cannot be assured, due to network mobility or harsh environmental conditions, the designated eNB could be dynamically elected based on parameters of interests, e.g. cell stability. Ultimately, the fire-fly synchronization technique could be applied if a fully distributed approach is required [109].

Coding: The PHY layer uses orthogonal frequency division multiple access (OFDMA) in a single frequency mesh network, where all network nodes eNBs, eUEs and UEs share the same resources both in downlink and uplink. In downlink (eNB-to-eUE) a *Decode-and-Forward* DF technique is implemented. Then on the second hop in uplink, we apply a distributed Alamouti coding scheme [67]

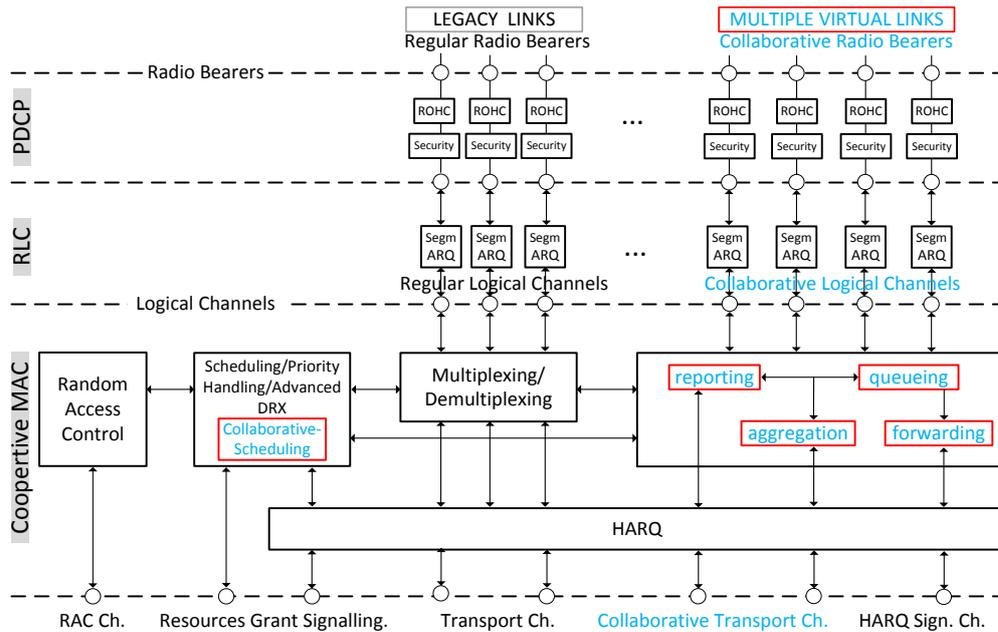

Figure 29: eUE MAC layer architecture and collaborative logical channels: The functional blocks *aggregation*, *forwarding*, *reporting* and *queueing* and *co-scheduling* allow for buffer-aided collaborative packet forwarding to interconnect isolated eNBs.

in order to exploit the diversity gains offered by eUEs for forwarding packets and implementing a virtual MIMO antenna. The destination eNB specifies the same time-frequency resources for the framing allocation to the eUEs by sending them a scheduling grant with an additional information related to the PDUs sequence number, size and HARQ id. Then, each eUE performs Alamouti coding independently and transmits the codes to the destination eNB. At the end the destination eNB requires at least one eUE to have correctly transmitted so as to be able to decode the Alamouti code. Therefore this technique allows for flexible coding as it is robust to the number of participating eUEs that have correctly send their codes.

Advantages of PHY design:

- eUEs belonging on a VL can dynamically participate in the collaborative forwarding a-priori regardless their respective to eNBs link quality. At least one eUE is required to establish a VL in-between two adjacent eNBs. Relying on the standard LTE detection and synchronization procedures, the maximum number of eNBs that an eUE is permitted to obtain the synchronization is three, we exploit this feature for the connection procedure at E-UTRAN.
- A significant advantage of the Alamouti coding scheme (at PHY layer) is that it utilizes eUEs as autonomous antenna elements. So, it can operate

independently to the number of active transmitting eUEs since this is not required by the receiver to decode the signal.

MAC Layer Design.

To operate effectively on collaborative packet forwarding, MAC layer, apart from the legacy 3GPP procedures, requires a sophisticated mechanism to manage a VL and perform packet forwarding. Packets are encoded in the source eNB with DF and then are broadcasted to the eUEs, where after successfully received by the eUEs, they are decoded and stored in the eUEs buffer queues maintained at the MAC layer. The reason why the packets are not forwarded directly to the destination eNB is twofold: *i)* In legacy 3GPP LTE, eNBs schedule packet transmissions, therefore eUEs cannot autonomously decide to transmit without having received a scheduling grant request by the destination eNB (It should be considered here that the eUEs have already notified eNBs through a buffer status report (BSR) about their PDU availability). *ii)* If eUEs perform packet transmissions as soon as they receive them, synchronization and over-the-air signal level combining of the packets cannot be guaranteed at the second hop (eUEs-to-eNB).

The new MAC layer that is designed to enable eUE packet forwarding for collaborative transmission is illustrated in Fig. 29 and is composed of five additional functional blocks to handle the VL between two end-points, namely:

- *queuing*: It handles packet storage on buffers maintained by the MAC layer. When a packet is correctly received by eUEs, it is stored locally at MAC buffers waiting to be scheduled by the destination eNB. The buffer supports indexing mechanisms using AVL trees for PDUs storage so as to optimize requests for PDUs that are identified by their sequence number (SN) and their PDU size.
- *reporting*: It sends periodically the MAC buffer status report (BSR) to the destination eNB indicating which MAC protocol data units (PDUs) have been correctly received and stored.
- *aggregation*: It is used to concatenate the requested MAC PDUs instructed by the destination eNB.
- *forwarding*: It identifies whether an incoming PDU on the intermediate eUEs is related to a VL, in which case queuing block will be instructed to store the PDU in a buffer associated with the destination eNB.
- *co-scheduling*: It schedules the outgoing PDUs on the intermediate eUEs corresponding to a VL requested by the destination eNB.

eUE Cell Association and Initialization: eUE initialization follows the same process of a legacy UE performing “initial attach” to its serving eNB. The eNB that has access to the core network provides the S-GW and P-GW functionalities. The eUE retrieves configuration parameters from this certain eNB during its initial attachment and also a list of other eNBs to which it is allowed to attach additionally. Then, RRC connection reconfiguration procedure is triggered for establishing a second connection to another (moving or core-isolated) eNB reported on the aforementioned list. During this establishment procedure each eNB initiates apart from the setup of the regular bearers for the S₁, the virtual data radio bearer interfaces and the corresponding PDU buffer queues.

Virtual Link setup: When instructed by the higher layer, a VL establishment procedure is triggered by the source eNB to setup a collaborative radio bearer (CO-RB). Through this procedure, the VL will be mapped to a set of physical links (PLs) from a source eNB to eUEs and from eUEs to a destination eNB. A VL provides an abstraction to the cooperative transmission at the MAC layer. Thus, the multiple access scheme at the higher layer perceives the lower PHY layer of the protocol stack still as a packet erasure link even though it may be decomposed into several point-to-point links. A VL is used as a means of hiding the information to higher layers: that is, a VL between two points is composed of several point-to-point links formed with the aid of intermediate forwarding eUEs. An eUE can participate at the same time to multiple VLs. (see for example Fig 27 where a PL can be used by multiple VLs and Fig. 29, where these VLs are contemplated on the eUE side.) The MAC layer is responsible for managing the virtual/logical links. More specifically the MAC layer is responsible for identifying the links that will be created in order to complete a single packet transmission between two specific endpoints. Moreover, it is responsible for the identification and scheduling of collaborative transmissions both in downlink and uplink direction.

For that reason, we introduce the concept of the Collaborative-RNTI as an identification number to differentiate a regular transmission from a collaborative one. In LTE, an RNTI (Radio Network Temporary Identifier) is a kind of an identification number. There are many type of RNTIs used for example to identify paging, system information, cell or random access procedures. Specifically, this CO-RNTI type, is used for indicating that a certain packet is on a collaborative transmission via a VL. The CO-RNTI is carried as a part of the MAC header in the Control Packets that are transmitted from an eNB to eUE in order to establish the VL. A collaborative transmission over a VL requires at least one eUE

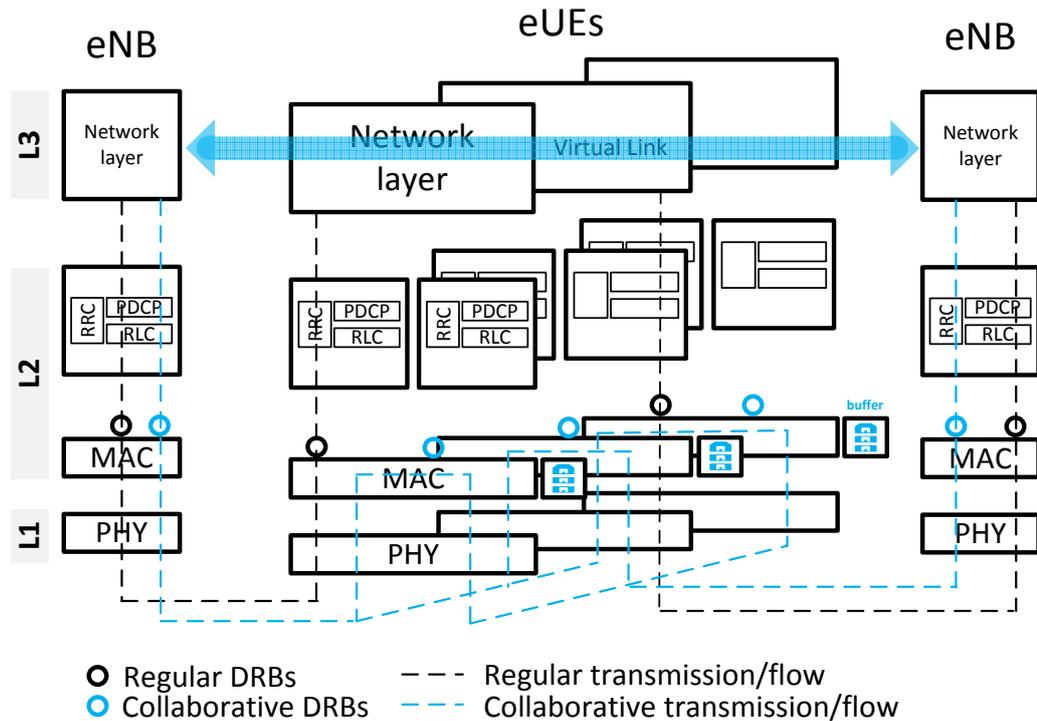

Figure 30: Collaborative Transmission over a virtual link. eUEs adopt a flexible protocol stack so as to be able to associate to two eNBs and perform efficiently L2 packet forwarding.

acting as packet forwarder and two CO-RNTIs that describe the point-to-point transmission on the (eNB-eUE) physical link. Two CO-RNTIs (an ingress and an egress) can participate to form a VL setup. The ingress CO-RNTI is used by the destination eNB to identify the appropriate buffer - queue in the respective eNB so that to be able to schedule the packets stored (which were previously indicated to the destination eNB by the same eUE). From the perspective of the destination eNB that needs to communicate back to the source eNB over a collaborative transmission, this design is symmetric and another CO-RNTI is used that describes the transmission being done from the destination eNB in this point-to-point link towards source eNB via an eUE. That CO-RNTI refers to the egress CO-RNTI. Therefore, the least number of CO-RNTIs at a given eUE that is essential to compose a bidirectional VL is two.

Link Adaptation, Adaptive Modulation and Coding (AMC) - Coding Rate:

In LTE, Adaptive Modulation and Coding (AMC) Scheme is performed according to the CQI values that UEs report back to the eNBs so as to support the highest Modulation and Coding Scheme (MCS) that can effectively decode packets with a BLER probability not exceeding 10% [101]. For a given MCS an appropriate code rate is chosen relying on the Table 7.2.3.1 of 3GPP TS36.213. Therefore, link adaptation matches the transmission parameters of MCS and

eNB CO-Scheduler: A MAC Layer scheduler for PDUs collaborative transmission.

Input : $u \in \mathcal{U}$ of selected eUEs and $V \in \mathcal{V}$ VLS.

Output: Collaborative PDUs transmission over VLS enabled by eUEs.

Data: Request N PDUs

Result: Grant resources for $u \in \mathcal{U}$ eUEs.

```

foreach  $TTI$   $t$  do
  foreach  $V \in \mathcal{V}$  /* Virtual Links. */ do
    foreach  $u \in \mathcal{U} \cup V$  do
      Receive a BSR for  $N$  PDUs identified by their SN, size and HARQ id.
    if  $\mathcal{U}' \subseteq \mathcal{U} \cup V$  respond with a positive BSR for  $N' \leq N$  PDUs then
      foreach  $u \in \mathcal{U}'$  do
        Grant resources for scheduling  $u$  eUE to transmit  $N'$  PDUs.
        Acknowledge PDU reception/failure to HARQ for transmitted PDUs in
         $t - 1$  TTI.
      else
        Notify HARQ to manage a reschedule of  $|N - N'|$  PDUs.
    foreach  $u \in \mathcal{U}$  do
      Provide the Channel State and CQI reports to the higher layers for the PL
      between  $u$  and eNB.
  
```

coding rate to the channel conditions. It should be clarified here that UEs in LTE, and hence eUEs are not permitted to deliberately decide about an autonomous MCS and coding rate selection. This is a control information that is instructed by the eNBs so as to optimally control and configure transmissions within the cell. Moreover, all the resource blocks within a subframe that are allocated to a certain user should use the same MCS. A key issue in the design of AMC policy in the two-hop topology interconnecting two eNBs is whether the MCS assigned to a specific eUE for a collaborative transmission should be the same over the two hops or different exploiting the intermediate buffer storage at the eUEs. In the 1st case, the source eNB uses that MCS that captures the worst CQI over the two consecutive physical links for the eUE configuration so as to minimize packet drops and sustain adequate end-to-end communication quality. In the 2nd case, each interconnected eNB can opportunistically use a different MCS for the transmissions with the bridging eUE relying on the fact that packets are temporarily stored in the buffer queues in order to be transmitted with the best possible MCS over each physical link.

eNB MAC CO-scheduler: In LTE cellular networks, packet scheduling decisions are orchestrated by eNBs. Therefore, eNBs are responsible to decide

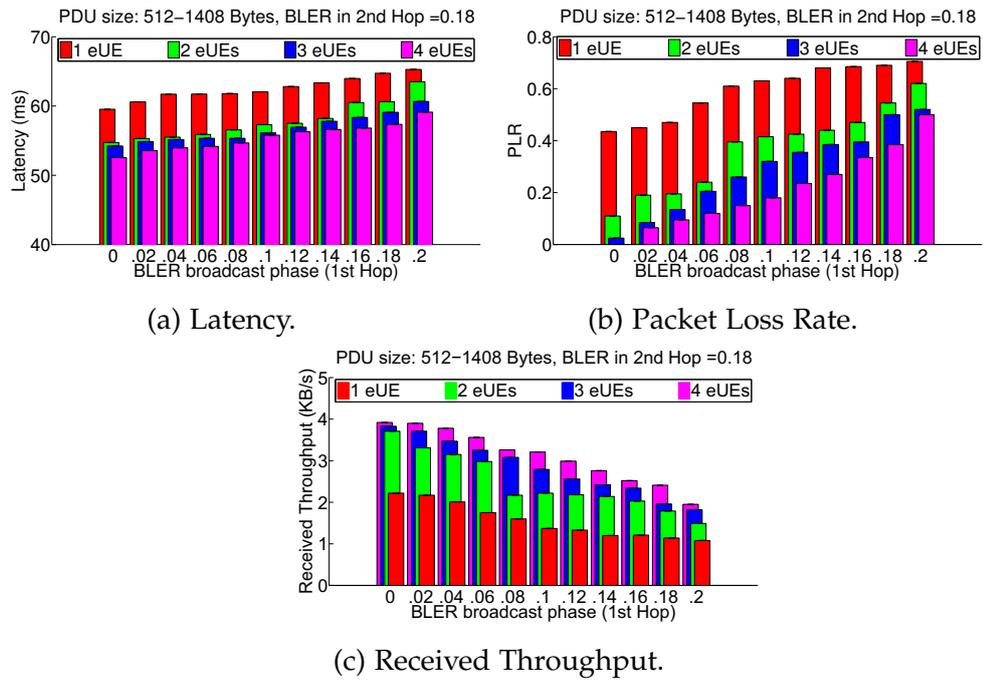

Figure 31: OAI Measurement Results of a LTE wireless mesh network enabled by eUEs.

which packets should be transmitted by whom by requesting a buffer status report (BSR) from the collaborating eUEs. A source eNB schedules the broadcast transmission, while the destination eNB schedules a CoMP transmission in uplink in the same way as in downlink. Until now, eNB schedulers have aimed either at the sole optimization of a specific metric (i.e. max. throughput, or min. delay) or aimed at attaining desired trade-offs for achieving a balanced compromise between different competing interests (i.e. Proportional Fairness or Min. Power vs. Delay). To effectively leverage eUEs for benefiting from a collaborative transmission at the MAC layer, we advance the eNB scheduler - apart from applying a specific policy - so as to be able to indicate the common packets that are stored in eUEs' buffers and are identified by their sequence number (SN) and PDU size.

The introduced eNB CO-scheduler is capable of selecting a subset of collaborating eUEs as this is instructed by higher layers and network-level cooperation. The selected eUEs are leveraged to store incoming packets and convey traffic when this would be instructed to them by the destination eNB. eUEs with bad link qualities that cannot support a predefined CQI C_{th} to sustain a certain MCS M_{th} and coding rate, will still be able to contribute to the signal by transmitting a common packet by exploiting Alamouti coding and CoMP techniques.

Flexible eUE Protocol Stack: eUEs adopt a light-weight and flexible networking mechanism for mobile devices enabling them to operate simultaneously on two cells. Fig. 30 illustrates the protocol stack of this mechanism that enables collaborative packet forwarding and multiple DRB reception. Observe that eUEs adopt in L2 (RRC, RLC and PDCP sub-layers) a dual-stack protocol in C-plane and D-Plane. This allows for eUEs to associate and communicate in parallel with two different eNBs and handle simultaneously regular transmissions. Additionally, the aim is to enable packet forwarding at the MAC layer so as to prevent packets in a collaborative transmission from passing through the whole protocol stack aiming to reduce communication latency when this collaboration is identified with the appropriate collaborative RNTI (Data plane). At L1 a source eNB broadcasts packets to collaborative eUEs. If these packets are correctly received by the eUEs and belong to a Collaborative Data Radio Bearer, the L2/MAC of eUEs identifies them and stores them temporarily in buffers. Then a collaborative CoMP transmission in uplink is scheduled by the destination eNB so as to activate eUEs to transmit the requested PDUS identified by their SN. L2 transmission presents an abstraction to the L3 layer where the VL is established by hiding the point-to-point physical transmissions. The above architecture enables eUEs being capable of handling simultaneous traffic that is originated and destined from interconnected eNBs in a seamless and efficient manner. This approach is backwards compatible with legacy UE operation.

Advantages of MAC design:

- It evolves RAN by introducing a light-weight mechanism for packet forwarding and packet storage at L2.
- It leverages eUEs to act as active network elements.
- It establishes VL connections for collaborative transmissions. Thus, hiding information to upper layers aiming efficiently to reduce end-to-end communication latency.
- It offers radio aggregation benefits by allowing eUEs to associate and communicate simultaneously with multiple eNBs. Thus, improving their aggregate rate.

5.4 PERFORMANCE EVALUATION

In this Section, we demonstrate the performance evaluation and the validation of the rationality of the proposed architecture. We first present the obtained gains considering packet level forwarding when interconnecting two eNBs for various number of employed eUEs, in terms of throughput, latency and packet loss rate. Moreover, we demonstrate eUEs' benefits that stem from multiple connectivity to eNBs and from the exploitation of diverse radio data paths in terms of received throughput.

5.4.1 *OpenAirInterface Emulation*

We leveraged OpenAirInterface (OAI) to test the performance of the collaborative forwarding in a practical setting, the distributed synchronization procedures and the 3GPP protocol operations for eNBs and eUEs (full implementation code is online available:[10]).OAI is an Open-source software implementation of the 4th generation mobile cellular system that is fully compliant with the 3GPP LTE standards and can be used for real-time indoor/outdoor experimentation and demonstration. OAI features a built-in emulation capability that can be used within the same real execution environment to seamlessly transition between real experimentation and repeatable, scalable emulation [34]. Specifically, two channel and physical layer (PHY) emulation modes are supported which differ in the level of detail at which PHY is realized.

Table 7: LTE-A TDD System Configuration.

<i>Parameter</i>	<i>Value</i>	<i>Parameter</i>	<i>Value</i>
<i>Carrier Freq.</i>	1.9 GHz	<i>max eNB TX Pow.</i>	20W [43dBm]
<i>Bandwidth</i>	5MHz	<i>Fading</i>	Channel AWGN
<i>Frame Duration</i>	10ms	<i>Pathloss</i>	0dB
<i>TTI</i>	1 ms	<i>Pathloss Exp.</i>	2.67
<i>UEs</i>	1,2,3,4	<i>Mobility</i>	Static
<i>RBs per TTI</i>	25	<i>Traffic Type</i>	UDP

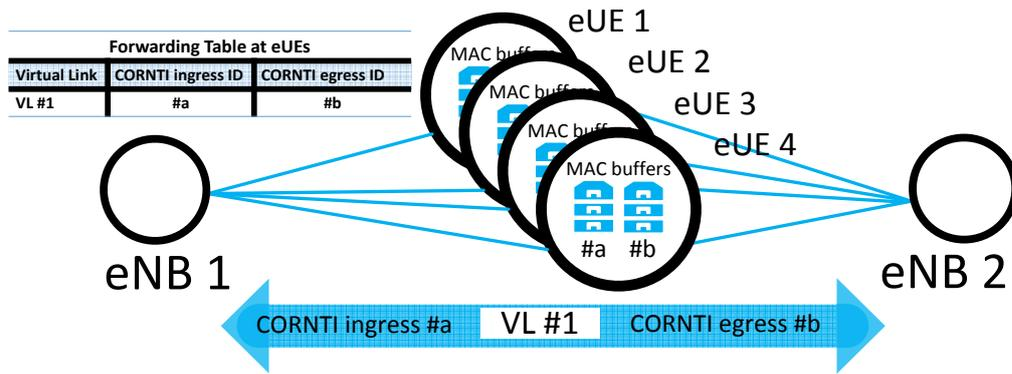

Figure 32: Logical topology for the performance evaluation scenario: A VL is setup to interconnect two eNBs with the aid of 4 eUEs. Each eUE maintains a forwarding table of CO-RNTIs so as to identify the VL and the respective MAC buffers.

5.4.2 Experimentation

Topology Description: In our system validation scenario, there exist two eNBs and four eUES located in an area of 500m^2 . Table 8 summarizes the system configuration setup and Fig. 32 illustrates the logical topology overview.

Leverage eUEs to provide backhaul access connectivity to core-isolated cells: The MAC layer performance is measured in terms of throughput, packet loss and latency for different number of UEs= $\{1, 2, 3, 4\}$ and for different BLER probabilities for the backhaul link (1_{st} hop: DL source eNB-to-eUEs) and for a bad channel configuration on the 2_{nd} hop UL (eUEs-to dest eNB) characterized by a BLER probability equals to 0.18. The above setup captures a harsh scenario where eUEs assistance is validated. The traffic pattern is a constant bit rate of 4KB/s and PDUs' payload ranges from 512 – 1408 Bytes that means extra delay and overhead due to de/fragmentation and reassemble in RLC. Fig. 31 illustrates the obtained results for the above scenario and demonstrates clearly the eUEs contribution. As the number of employed eUEs increases the latency and packet loss rate reduces while there is an improvement on end-to-end throughput performance. For the sake of comparison 3GPP, latency requirements for QoS Class Identifiers QCIs 1 and 4 that characterize two guaranteed bit rate (GBR) bearer types for VoIP call and Video streaming are set to 100ms and 300ms respectively [101]. Using 4 collaborative eUEs the measured latency is constantly below 60ms for all BLER probabilities.

Collaborative Rationale: We need to clarify that the largest portion of the latency is experienced on the 2_{nd} hop in uplink as the destination eNB needs to schedule each eUE independently, while in the 1_{st} hop in downlink the

source eNB performs broadcast transmission. The actual benefit that we obtain, that is the gist of collaborative transmission is that as the number of eUEs increases the respective periodicity that the eNB receives the PDUs from the collaborative MAC actually decreases. Keep in mind the four way handshake that needs to be acknowledged between the eNB and each eUE for performing the scheduling request and the scheduling grant and consider the coherence of this procedure in time as the number of eUEs increases and have the same sequence of PDUs to transmit.

The impact of queuing storage: Each eUE maintains for each VL two MAC buffers for the corresponding ingress and egress CO-RNTIs (see Fig. 32). Those buffers are utilized reciprocally in both directions to store the incoming PDUs identified by their ingress and egress CO-RNTIs. The absence of the buffers would occur all the PDUs to be lost as it would be impossible to be forwarded directly to the dest eNB without scheduling. In our experimentation we used a maximum buffer size equals to 100 PDUs. As the buffer storage capacity increases, the PLR is expected to be reduced. However, this comes at a cost of increased overhead and storage for the MAC layer that needs to be attained. Another benefit from maintaining buffers is that they used to store the PDUs until their reception will be acknowledged. As the BLER increases, the PLR grows slightly constant (see Fig. 31.(b)) as buffers aid in robust transmission and packet recovery.

The benefit of the signal level cooperation in throughput: The actual throughput benefit that is attained by the destination eNB (see Fig. 31.(c)) is due to signal-level cooperation. The more the employed eNBs, the over the air signal combining allows the dest eNB to experience increased received throughput.

Exploit multiple eNB communication capabilities to improve eUEs networking performance: Fig. 33 illustrates the measured results for the scenario where an eUE is benefited from multiple eNBs connectivity. In this scenario, the payload size ranges from 64-128 Bytes and we measure the received throughput gain when the eUE is served by two eNBs vs. a sole eNB service for different BLER probabilities. UDP constant bit rate traffic of 2.1 KB/s is transmitted by both eNBs. The queue size has no impact at all as the eUE absorbs traffic. As can be seen from Fig. 33.(a) the eUE almost doubles its throughput when experiences dual eNB connectivity and maintains this difference slightly reduced as the BLER increases. This slight throughput reduction is due to the PLR that increases as the bad channel quality defects the communication (see Fig. 33.(b)).

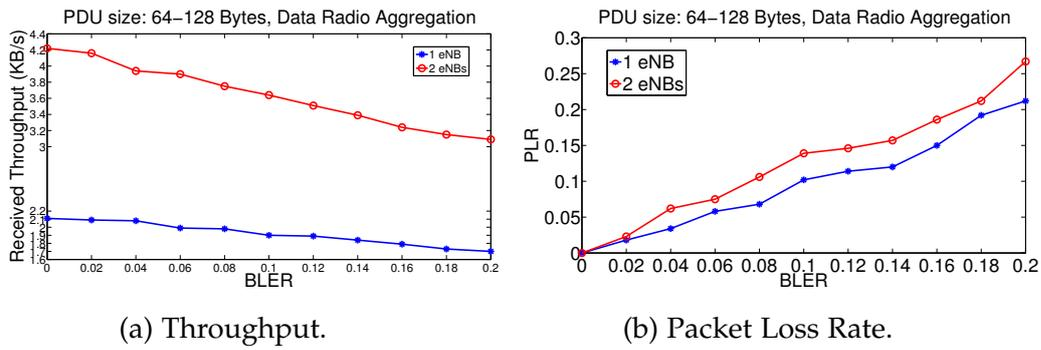

Figure 33: OAI Measurement Results of an eUE experiencing multiple eNB communication.

5.5 RELATED WORK

In pursuit of designing a scalable and resilient architecture, we differentiate from prior studies in the literature dealing with the problem of backhaul access provision and packet relay forwarding.

Backhaul access: The explosion in mobile networking and multimedia applications have swiftly shifted backhauling from a state of low priority to a centre of attention. Andrews in [27] distills the most important shifts in HetNets arguing that efficient backhauling through picos and femtos can significantly affect both operators and users. A substantial number of works provide extensive study about the verification of functionality and feasibility for backhaul access solutions in cellular and heterogeneous networks (HetNets). Works in [49, 107, 89, 116] aim at offering improved wireless backhaul access solutions and pose significant design and deployment challenges so as to be capable of introducing an automation toward self-organizing-networks (SON). Our approach not only complements those studies but also differs by proposing a flexible and light-weight architecture that can fully exploit eUEs as active networks elements/resources.

Relaying and packet forwarding: In their seminal works [100], Sendonaris *et al.* advocate that in a multi-hop relay scenario, cooperative communication is being considered as an efficient solution for transmissions, as it provides robust and resilient forwarding by recruiting multiple intermediate relays to collaboratively transmit the source signal to the destination. Authors in [66, 91], compare different relay types and topologies in LTE-Advanced and WiMAX standards. Simulation results show that relay technologies can effectively improve service coverage and system throughput. Those works motivate the applicability of packet forwarding solutions in relay assisted networks. Our work is differenti-

ated from the above in the context that it rethinks the end-to-end information transfer as relays terminate the S1-AP protocol. The current practice considers relays as a part of network planning that maintain sufficient backhaul access to the core (MME/S-GW), while in our architecture eUEs adopt a light-weight design to effectively enable new use cases in small and moving cell scenarios.

Although both relays and eUEs operation requires a dual protocol stack, a distinctive characteristic is that RNs play the role of UE with respect to DeNB and the role of eNB with respect to the UEs, while the introduced eUEs remain always UEs with respect to the connected eNBs. Moreover, our work shares the same concept of enabling a holistic approach on the management of network resources with the experimental study in [54]. Authors discuss the evaluation of a cooperative relaying scheme that exploits QMF for WiFi infrastructure networks. A PHY layer design is presented motivating the need for a close interaction with a suitable MAC to exploit the benefits of relaying diversity either through link switching or link cooperation.

Cooperative Communications: Two significant works [87] that are strongly related to our study present a novel cross-layer design that exploits benefits of PHY/MAC interworking to enable cooperative relaying in a WiMAX system (a competitive to LTE technology). Authors propose a MAC layer protocol, named CoopMAX that is in compliance with WiMAX standards to allow for leveraging intermediate relays to service cell edge users. Contrary to the above, our work introduces the concept of collaborative radio bearer establishment in LTE, where multiple eUEs can be leveraged to support backhaul access connectivity to core isolated eNBs as well as to benefit by multiple inter-node radio aggregation. In a preliminary work in [43], we studied the throughput efficiency in the presence of two UEs when DF is used in system-level simulator in absence of any protocol. We enhanced this preliminary work aiming at enabling low latency transfer in inter-cluster communications, introducing a full protocol implementation mechanism for MAC/L2 packet forwarding that exploits buffer aware scheduling.

5.6 CONCLUSIONS

Contemporary cellular networks are significantly strained due to the unprecedented growth of data traffic caused by mobile users. As this situation is likely to oppress the operators for delivering services to satisfy user demands, the need for a light-weight and scalable architecture that can also en-

able new and diverse use-cases becomes essential. In this Chapter, legacy UEs are evolved to become active network elements (eUEs) and collaborate to forward packets at L2 (packet-level cooperation). Our work has been motivated by the need to introduce a *holistic* approach in future cellular networks enabled by the interplay of three pillars (i) signal, (ii) packet and (iii) network level cooperation. The intellectual merit of the proposed architecture consists of the enabling of alternative wireless backhaul access to moving/core-isolated cells while also allowing users to reap benefits from communicating with multiple eNBs simultaneously. Moreover, this architecture, being a promising solution to enable wireless meshing can impact on future cellular networks. eUEs motivated by monetary compensation or service elasticity offered by the operators can admit part of the cellular traffic and participate in this collaborative forwarding, while operators exploit eUEs as a service to reduce their capital and operational costs [99, 61]. Our prototype evaluation in the OAI [34, 10] system validation platform demonstrates throughput and latency performance improvements and validates its individual rationality.

C₂M: MOBILE DATA OFFLOADING TO MESH NETWORKS

As the unprecedented growth of mobile data traffic places significant strain on cellular networks, alternative plans for exploiting already existing and under-utilized wireless infrastructure, become quite attractive. In this Chapter, we study data offloading for LTE-A cellular mobile users to WiFi mesh networks, which are built and managed collaboratively by users. Such networks are developed in the context of community networks or, recently, as commercial services among residential users. Mobile network operators can lease these mesh networks to offload their traffic and reduce their servicing cost. In this context, we introduce an analytical framework that determines which mobile users should be offloaded, based on the energy cost incurred to the cellular base stations (eNB) for serving their demands. Accordingly, we design a routing policy that the mesh network can employ so as to serve the offloaded traffic with the minimum possible cost. Moreover, the reimbursement offered by the operator should be dispensed to the different mesh users, according to their contribution and added-value significance. We address this issue by employing the Shapley value profit sharing rule, which ensures the participation of the mesh nodes in this joint task. We evaluate our work by simulating the operation of the LTE-A network, and conducting testbed experimentation for the mesh network. The results reveal significant savings for the eNBs power consumption and significant compensation profits for mesh network users.

Keywords – Data Offloading, Network Economics.

Related Published Work:

- C.[2] Apostolos Apostolaras, George Iosifidis, Konstantinos Chounos, Thanasis Korakis and Leandros Tassiulas. “C₂M: Mobile Data Offloading to Mesh Networks.” to be presented in *Global Communication Conference, Globecom*, 2014

6.1 INTRODUCTION

6.1.1 Motivation

Today we are witnessing an unprecedented growth of mobile data traffic [63] that places significant strain on cellular networks and increases the CAPEX and OPEX of mobile network operators (MNOs). Therefore, it is not surprising that methods for offloading part of this traffic to WiFi networks are gaining increasing interest both from industry and academia [24]. At the same time, recent technological advances and standardization efforts, such as the Hotspot 2.0 protocol defined by the WiFi Alliance, and the ANDSF service of 3GPP[23], render such solutions highly attractive by encompassing simplified roaming and seamless handover techniques. In this new era, WiFi mesh networks that are built and managed collaboratively by users, can play a very important role.

Such mesh networks emerge nowadays in various different contexts. First, several community networks (CNs) have been deployed by residential users for sharing content and network resources [5]. CNs complement conventional cellular network infrastructures, mainly in areas where coverage is poor, and/or access is expensive. Therefore, they constitute an ideal solution for offloading mobile data. Similar models have been recently commercially launched¹ [16], [3]. For example, the BeWifi service of Telefonica [3] enables residential users in proximity to create mesh networks and share their Internet access. The idea is to exploit the diversity, in the time domain, of users' needs and network resources, and increase the average Internet capacity per user, through resource pooling. Such mesh networks can serve as an offloading solution under a proper (monetary) compensation offered by the MNO.

This promising *cellular-to-mesh (C2M) collaborative data offloading architecture* inevitably raises three basic issues. First, the MNO should determine which mobile users (MUs) are the most intense resource-consumers and hence more preferable to be offloaded. The answer depends on the demand of each user, the quality of her cellular channel, as well as her eligibility to be offloaded based on the mesh network coverage. Second, the mesh network should devise the minimum-cost servicing policy for admitting this offloaded traffic. This policy should take into account the energy consumption of the mesh nodes,

¹ Besides, today there exist many WiFi communities, such as FON [8], where users can coordinate and provide similar offloading services.

the available capacities of the point-to-point and Internet access links, and the respective Internet usage costs. Finally, the mesh nodes should agree on a rule for sharing the compensation offered by the MNO, based on their contribution and incurred servicing costs. This is necessary in order all nodes to be willing to participate in this collaborative offloading service.

In this work, we study this problem both from the perspective of the operator and the mesh network. First, we investigate what are the potential cost savings of an operator from offloading a user request, and how should he decide which of his subscriber(s) to offload. We formulate this as an optimization problem where the objective is to minimize the energy consumption costs of the operator, that is probably the major cost component of cellular networks. This calculation serves as the basis for estimating the reasonable reimbursement that the operator should offer to the mesh network so as to admit the offloaded data traffic. Accordingly, we consider a general model for WiFi mesh networks and provide an optimization framework for deriving the minimum-cost servicing policy. This solution takes into consideration the Internet access costs and the energy consumption of each mesh node. This way, the mesh network ensures that it will have the maximum possible benefits from serving cellular users.

6.1.2 Methodology and Contributions

The proposed architecture is depicted in Fig. 34. We consider a macrocell of an LTE-A network where a base station (BS), also known as eNB, serves a set of mobile users MUs (or user equipments UEs) who also have WiFi interfaces. The macrocell partially overlaps with a WiFi mesh network that is managed by a set of residential users (other than the MUs) [3]. Hence, a subset of the MUs are in range with one or more access points (APs) of the mesh network. The users differ also on the amount of data they need to download or upload from/to the Internet, and their channel conditions with the base station.

First, we investigate the cost savings of the operator when offloading user requests. We assume that the main cost component of the cellular network for this setting is the energy consumption of the base station [69], [32]. The MNO determines the spectrum and the transmission power that needs to allocate to each MU so as to satisfy her requests, while minimizing the aggregated energy consumption cost of the base station [57], [81]. Accordingly, the BS decides to offload the user(s) that consume the most energy. This decision is constrained

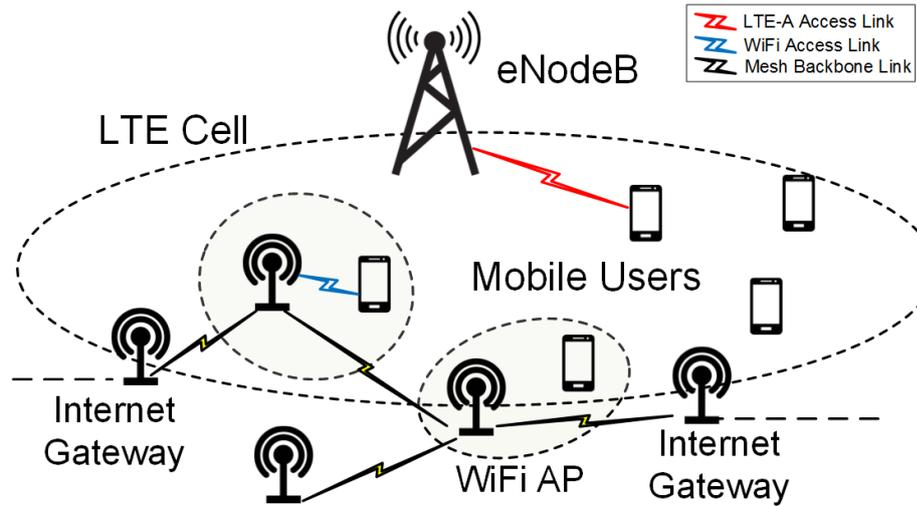

Figure 34: An LTE-A macrocell serving mobile users that are partially covered by a mesh network.

by the availability of the mesh network, as the offloaded users should be in range with an AP having adequate capacity.

Once the operator has decided the traffic that should be offloaded, the mesh network determines how this data will be further routed to/from the Internet gateways. These decisions are based on the available resources of the network, i.e., the point-to-point and Internet access capacities of the nodes, and also take into consideration the respective energy consumption and Internet usage costs. We cast this as a multicommodity minimum-cost flow optimization problem, where each commodity corresponds to the data of each offloaded mobile user. Nowadays, such policies can be derived and imposed in a very small time scale [51].

Accordingly, we design a mechanism for dispensing the net benefit of the mesh network, i.e., the received compensation minus the servicing cost, among the mesh nodes. This rule is based on the notion of the Shapley value [33] which ensures that the cooperating mesh nodes will agree to jointly provide the offloading service. In particular, we define a respective cooperative game [84] and prove that, based on this sharing rule, all the mesh nodes will have positive net benefits, and hence an incentive to participate.

The proposed offloading architecture takes into consideration the particular characteristics of such systems. For example, user association (and hence the

offloading decisions) cannot be derived in a very small time scale as base station reselection requires several seconds [97], [57]. On the other hand, the eNB's resource allocation decisions can be taken in ms (every transmission time interval, TTI), but channel quality feedback information (CQI) from the MUs to the eNB, which are used for estimating the channel gains, are available every tens of ms (with a minimum of 8ms). We explicitly model these limitations. Moreover, for investigating the offloading potential of the mesh network, we executed experiments in the NITOS wireless testbed [13], using a setup that resembles a mesh network among residential users, e.g., such as in BeWifi [3].

To this end, the contributions of this work can be summarized as follows:

- *C2M Architecture*. We propose a new architecture for offloading mobile data to collaborative mesh networks. The proliferation of community mesh networks [5], and similar commercial mesh networking platforms [3], [16], render such solutions very promising for alleviating cellular network congestion.
- *Optimization Framework*. We introduce an optimization framework that can be used for calculating the cellular energy cost benefits, for each user, and the respective energy and Internet usage costs for the mesh network that admits the offloaded traffic. Our analysis can be used for different mesh network architectures [3], [5]. Moreover, we provide a cost-sharing rule, based on the Shapley value, and prove that it ensures the participation of all the mesh nodes.
- *Performance Evaluation*. We evaluate the above decision framework, using a detailed simulation analysis. Moreover, we conducted extensive experiments in an actual mesh network deployed in the NITOS testbed [13], and we measured the energy consumption costs and the perceived user performance in terms of experienced delay.

The rest of this Chapter is organized as follows: In Section 6.2 we discuss related works. Section 6.3 introduces the system model for the cellular and the WiFi mesh network. We formulate the respective optimization decision frameworks in Section 6.4. In Section 6.5 we present the numerical results, the experimental setup and the experiments' outcomes. Finally, we conclude in Section 6.6.

6.2 RELATED WORK

Several recent studies have quantified the benefits of macrocellular data offloading to WiFi networks [78], [96]. These benefits can be further enlarged when the user needs are delay tolerant [52]. Clearly, the offloading performance depends on the APs' availability. Apart from operator deployed APs, another recently proposed solution for addressing the availability issue, is the leasing of third-party WiFi APs [65], [90]. This method enables the dynamic expansion of network offloading capacity, without any significant CAPEX or OPEX costs.

We extend this architecture by proposing data offloading to third-party mesh networks deployed and managed by users [5], [16], [3]. The offloading capacity of these networks is significantly larger from single APs as, not only they aggregate more network resources (e.g., in terms of Internet capacity), but also increase their availability through resource pooling, i.e., exploiting the diversity of the nodes' needs and resources. For example, an AP not having currently Internet access (e.g., because it has exceeded its monthly quota), can admit and relay the mobile data traffic to another mesh node with adequate Internet capacity.

To quantify the benefits of this architecture, the operator needs to determine the resource allocation policy, in terms of resource blocks assignment and power transmission. This is particularly challenging for LTE-A networks since it requires the solution of a multi-variable optimization problem [57], [26]. Among the different possible policies, such as proportional allocation, the total power transmission minimization policy [57], [81], is of paramount importance for cost savings [69]. However, this is a well known NP-hard problem that can be either solved using exhaustive search methods for small instances (e.g., branch-and-bound), or various approximation techniques [80]. Here, we do not delve into the details of such an analysis. Besides, in order to reduce the complexity of the proposed mechanism, we decide which traffic will be offloaded based on the resource allocation policy of the eNB, which has to be devised for serving the users.

Finally, offloading can be seen as a type of vertical handover. Such mechanisms have been studied for integrating 3G and operator-managed WLANs. The handover policies vary from simple signal strength-based rules, to sophisticated schemes that consider the network load and the QoS requirements [83], [42]. The proposed offloading architecture here however, differs in that the

WiFi resources are not controlled by the operator. Moreover, such offloading schemes are typically used for best-effort services and hence there are no QoS concerns. Therefore, the main decision criterion is the cost reduction of the operator, while ensuring the delivery of the requested data.

6.3 BACKGROUND AND MODEL

In LTE-A networks, resource allocation decisions by each eNB can be devised in a very small time scale, namely every subframe of duration 1ms. However, these decisions require feedback from the mobile users (channel quality indicators, CQI) in order to assess the respective channels. This information is provided in larger time periods ranging from 8ms to even several frames (tens of ms) [97]. Frequent CQI transmissions improve the accuracy of resource allocation decisions but induce significant communication and computational overhead. Here, we assume that CQIs are transmitted once over several frames, and are used to calculate the respective channel gains. Besides the user associations and hence the offloading decisions can only be taken in a large time scale (of several seconds), due to eNB reselection constraints [97].

LTE-A Network. We consider the downlink operation² of one macrocellular base station for a time period of T subframes, possibly expanding over multiple frames. There exists a set \mathcal{N} of N users within the cell. Every user $n \in \mathcal{N}$ needs to download an amount of $D_n \geq 0$ bytes during this period. Some mobile users may be in range with one or more access points (APs), while some others may not be covered by any AP. The base station has a set \mathcal{M} of M available resource blocks (RB) that can be allocated to users in each subframe $t = 1, 2, \dots, T$. The value of M depends on the available spectrum. Hence, there are in total $M \cdot T$ RBs. The system is considered quasi-static, i.e., users do not join or leave the cell during the current time period, and the channels do not change significantly (flat fading). Note that, even if channels change rapidly, the eNB will not be aware of this fact, as users transmit their CQI parameters only once during this time period.

In the beginning of the period, the eNB devises the resource block assignment and power allocation policy for serving his users. Let $x_{nm}(t) \in \{0, 1\}$ denote whether RB $m \in \mathcal{M}$ is allocated to user $n \in \mathcal{N}$ during subframe t . Let

² The analysis for uploading is similar, although one should take into account the possible differences that may arise in the physical layer and the respective RRM techniques. We leave this as a future work.

$P_{nm}(t)$ denote the respective transmission power. For each RB the base station can determine a different transmission power. However, the total power consumption should not exceed a maximum level of aggregated transmission power P_{\max} Watt. Assuming orthogonal allocation of RBs [97], and ignoring inter-cell interference, i.e., we assume proper eICIC techniques are applied, the instant rate (in bps) for each user n is:

$$r_n(t) = \sum_{m=1}^M x_{nm}(t) W_b \log \left(1 + \frac{h_{nm} x_{nm}(t) P_{nm}(t)}{\sigma^2} \right) \quad (3)$$

where W_b is the symbol rate per RB³, and h_{nm} the channel gain of user n in RB m during the current time period. These parameters are estimated through the CQI feedback that is provided by the users, once every period T .⁴ Hence, the scheduling policy of the base station consists of: (i) the RB assignment vector $\mathbf{x} = (x_{nm}(t) : n \in \mathcal{N}, m \in \mathcal{M}, t = 1, \dots, T)$, and (ii) the power allocation vector $\mathbf{P} = (P_{nm}(t) \geq 0 : n \in \mathcal{N}, m \in \mathcal{M}, t = 1, \dots, T)$. Notice that this policy is derived by the eNB so as to serve the current user requests. At the same time, based on this policy, the operator determines which users will consume the most power and hence are more costly and should be offloaded.

The mesh network comprises a set of WiFi APs owned by different users-nodes⁵. Some of the APs are operating solely as relays, i.e., routing traffic to other APs, while other are operating also as gateways, i.e., connecting the mesh overlay to the Internet.

Mesh Network. The mesh network is described by a directed graph $G = (\mathcal{V}, \mathcal{E})$, where \mathcal{V} is the set of the $V = |\mathcal{V}|$ APs, and \mathcal{E} the set of the available links. Each node v comprises a wireless mesh router for the backbone links, and possibly a WiFi AP for serving local traffic (hereafter called *local AP*). Moreover, some of the nodes may have Internet connections. The channel fading gains, and

³ In a 3GPP LTE-A system, OFDM symbols are grouped into RBs. An RB has a total bandwidth of 180KHz, in the frequency domain consisting of 12 subcarriers with spacing of 15KHz. In the time domain, in one RB slot there are 7 symbols that last for 0.5ms. Each symbol can carry from 2 up to 6 bits based on the modulation, QPSK, 16QAM, or 64QAM.

⁴ It is possible to have more frequent feedback transmission. However, this increases the complexity and induces communication overhead in the uplink. Typical intervals are 8ms.

⁵ Here, with the term user we mean another set of entities, disjoint with the cellular users \mathcal{N} .

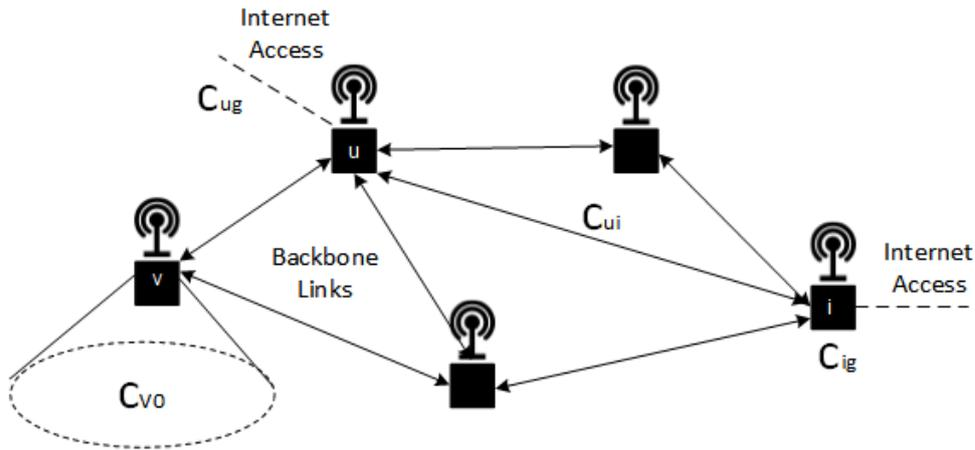

Figure 35: Mesh Network Architecture. Some nodes may have AP for serving local traffic and/or Internet access.

the network configuration are considered constant during the time period of interest⁶.

In particular, every mesh point-to-point link $(v, u) \in \mathcal{E}$ has an average available capacity of $C_{vu} \geq 0$ bps. Moreover, each node $v \in \mathcal{V}$ serving as an AP has an available capacity of $C_{v0} \geq 0$ bps for serving local traffic, and an Internet access capacity of $C_{vg} \geq 0$ bps. Notice that these are the available (“idle”) capacities, i.e., those that the mesh network has decided to assign to this offloading mechanism. Therefore, they may vary across different APs and backbone links. Such a segregation is possible with tools such as AFFIX and Click [1, 72].

The policy of the mesh network comprises the data routing decisions for serving the set $\mathcal{N}_o \subseteq \mathcal{N}$ of the users that are offloaded by the cellular network. Let $f_{vu}^{(n)} \geq 0$ denote the average flow (bps) of data transfer over link (v, u) for the offloaded user $n \in \mathcal{N}_o$ (commodity n). Also, $f_{v0}^{(n)} \geq 0$ denotes the WiFi flow of node v for serving locally offloaded traffic, and $f_{vg}^{(n)} \geq 0$ the Internet average rate of flow from node v . The mesh network policy denoted $\mathbf{f} = (f_{vu}^{(n)}, f_{v0}^{(n)}, f_{vg}^{(n)} : (v, u) \in \mathcal{E}, n \in \mathcal{N}_o)$, is constrained by the respective link capacities.

Additionally, each node $v \in \mathcal{V}$ is half-duplex constrained and cannot simultaneously send and receive flows with maximum rate to all her neighbors. Moreover, each node performance is limited by the concurrent transmissions in oc-

⁶ Tasks such as channel reallocation and AP deployment that may change the properties of the mesh network, involve many different entities (nodes of the network). Thus, it is not reasonable to assume that reconfiguration is accomplished very often.

curing her vicinity by her neighbors. Then, according to the interference protocol model [60], in order to be feasible, the policy should satisfy the following constraints [71] for each link $(u, v) \in \mathcal{E}$:

$$\sum_{n \in \mathcal{N}_o} \left(\sum_{i \in \text{In}(u)} \frac{f_{iu}^{(n)}}{C_{iu}} + \sum_{i \in \text{Out}(u)} \frac{f_{ui}^{(n)}}{C_{ui}} + \sum_{i \in \text{In}(v)} \frac{f_{iv}^{(n)}}{C_{iv}} + \sum_{i \in \text{Out}(v)} \frac{f_{vi}^{(n)}}{C_{vi}} \right) \leq 1 \quad (4)$$

,where with $\text{Out}(u)$ we define the set of nodes for which the node u has an outgoing flow, and with $\text{In}(u)$ the incoming set respectively. We need to clarify here that we do not consider the possibility of different channel assignment that would allow parallel transmissions over the point-to-point links. Nevertheless, such an approach can be easily incorporated in our model, e.g., see [71]. The local transmissions and the Internet access is realized over different channels and hence do not interfere with the mesh backbone links.

The mesh network policy should take into consideration the energy consumption of the mesh nodes. We denote with $e_{uv}^{\text{TX}} \geq 0$ and $e_{uv}^{\text{RX}} \geq 0$ (Joules/bit) the transmission and reception energy consumption for each link $(u, v) \in \mathcal{V}$, respectively. Also, $e_{v0}^{\text{TX}} \geq 0$ and $e_{v0}^{\text{RX}} \geq 0$ are the respective parameters for transmitting local traffic, which is expected to be lower than the point-to-point links. We do not consider the energy consumption for the Internet connections as these are considered wireline links. Finally, we denote with $p_v \geq 0$ the price node v pays per bit she downloads from the Internet. Notice that some users may have flat pricing scheme while others may have usage-based plans. In both cases, this price reflects the Internet access cost during the period of interest and without loss of generality it is assumed to be constant.

6.4 OFFLOADING DECISION FRAMEWORK

LTE-A Offloading Policy. In order to understand what is the servicing cost for each user n , we first need to analyze how the operator devises his resource allocation policy for serving the MUs (or UEs). In this context, the problem of the operator is to minimize the aggregate transmission power for the base station, while ensuring the data delivery constraints for the users that it serves. This can be written as follows:

$$\min_{\mathbf{P}, \mathbf{x}} \sum_{m=1}^M \sum_{n=1}^N \sum_{t=1}^T x_{nm}(t) P_{nm}(t) \quad (5)$$

s.t.

$$\sum_{t=1}^T r_n(t) T_0 \geq D_n, \forall n \in \mathcal{N}, \quad (6)$$

$$\sum_{m=1}^M \sum_{n=1}^N P_{nm}(t) \leq P_{\max}, \forall t, \quad (7)$$

$$x_{nm}(t) \in \{0, 1\}, P_{nm}(t) \geq 0 \forall n, m, t, \quad (8)$$

where $T_0 = 1\text{ms}$ is the duration of the subframe, and $r_n(t)$ is given by (3). We assume that this problem has a feasible solution [81] denoted $(\mathbf{x}^*, \mathbf{P}^*)$, i.e., the maximum transmission power and the available spectrum, are sufficient to serve the users.⁷

The benefits from offloading the traffic of a user $n \in \mathcal{N}$, can be calculated by taking into account the energy consumption cost of the eNB as well as the charged energy prices. The total operation power consumption of a base station is generally a linear function of the total transmission power [32], [69]. Clearly, the operator will decide to offload as many users as possible, based on the available mesh network capacity. Notice that we assume that the offloaded users are those that do not receive a guaranteed bit rate service (GBR) from the eNB, and hence there are no quality of service concerns. Yet, we explain below (and evaluate in our testbed deployment) that the offloaded users experience a comparable service from the mesh network.

Once the servicing policy of the base station has been devised, the offloading decisions can be determined. In this context, every mobile user is described by the amount of energy she will consume according to the solution $(\mathbf{x}^*, \mathbf{P}^*)$, the amount of data she requests, and whether she is covered or not by a mesh AP. The base station sorts the users in a decreasing order of energy consumption and selects the most energy-consuming that are eligible, i.e., within the coverage area of one AP. The exact amount of offloaded mobile data depends on the actual energy cost, which in turns is shaped by the energy prices. We emphasize here that this is a greedy method for determining the most energy consuming nodes as it leverages the results - policy that the eNB has to devise for serving its MUs. Finding the exact energy cost incurred by serving each user would require to solve multiple times the problem (3)-(6) in a very small time scale. This would induce huge computational complexity into the problem, especially for this small time scale. Hence, we opted to use the already devised resource allocation policy of the eNB.

⁷ If the eNB cannot serve all the users, some of them will be dropped. This case does not affect our analysis.

Mesh Network Servicing Policy. Once the base station has determined the set of users \mathcal{N}_o to offload, the mesh network determines the routing policy f so as to meet the data delivery requirements. We study the mesh network for a time period of Q seconds. Our experimentation results indicate that Q is comparable with the respective period T . Clearly, this depends on the mesh network available resources and its architecture, e.g., the number of links/hops connecting each AP to an Internet gateway. During this period, the data that will be downloaded from all the node-gateways and delivered to each user $n \in \mathcal{N}_o$ should satisfy her demand:

$$\sum_{v \in \mathcal{V}} f_{vg}^{(n)} Q \geq D_n, \quad \sum_{v \in \mathcal{V}} f_{v0}^{(n)} Q \geq D_n. \quad (9)$$

For each node v , and each commodity $n \in \mathcal{N}_o$, the flow conservation constraints should be satisfied [71]:

$$f_{vg}^{(n)} + \sum_{q \in \text{In}(v)} f_{qv}^{(n)} = f_{v0}^{(n)} + \sum_{u \in \text{Out}(v)} f_{vu}^{(n)} \quad (10)$$

where $f_{vg}^{(n)}$ is the flow node v downloads from the Internet, $f_{qv}^{(n)}$ is the incoming flow from each incoming node $q \in \text{In}(v)$ that has link to node v , f_{v0} is the flow for data delivery from v to user n , and f_{vu} is the flow delivered to each one of the outgoing neighbors of node v , $u \in \text{Out}(v)$.

The objective of the mesh network is to deliver the requested content, within the time period⁸ Q , while incurring the minimum possible cost. This will ensure that the community mesh network will have the largest possible net benefit which consists of the reimbursement given by the operator minus the incurred cost. The policy of the mesh network can be derived by solving the minimum cost flow optimization problem (MFP):

$$\begin{aligned} \min_f \quad & \alpha \sum_{v=1}^V \sum_{n \in \mathcal{N}_o} e_{v0}^{\text{TX}} f_{v0}^{(n)} + \alpha \sum_{(v,u) \in \mathcal{E}} \sum_{n \in \mathcal{N}_o} (e_{vu}^{\text{TX}} + e_{vu}^{\text{RX}}) f_{vu}^{(n)} \\ & + \sum_{v=1}^V \sum_{n \in \mathcal{N}_o} p_v f_{vg}^{(n)} \end{aligned} \quad (11)$$

s.t. (9), (10),

$$0 \leq \sum_{n \in \mathcal{N}_o} f_{vu}^{(n)} \leq C_{vu}, \quad \forall (v, u) \in \mathcal{E} \quad (12)$$

⁸ Notice that depending on the value of Q the network can decide about the QoS Class Identifier (QCI) to specify the offloading treatment. Assuming that $Q = T$, requires a full convergence between WiFi and LTE-A cellular network. For values of Q close to T , i.e. $Q \simeq T$, the considering time period is adequate for offloading, as it is justified by our experimentation results. In the case where $Q \gg T$ and hence $Q \gg D$ the problem is relaxed and delay tolerance is implicitly inserted, which should be clarified.

$$0 \leq \sum_{n \in \mathcal{N}_o} f_{vg}^{(n)} \leq C_{vg}, \quad 0 \leq \sum_{n \in \mathcal{N}_o} f_{v0}^{(n)} \leq C_{v0} \forall v \in \mathcal{V} \quad (13)$$

where parameter $\alpha \geq 0$ is properly selected so as to transform the energy cost to monetary cost (i.e., based on the charged energy prices or a stipulated compensation agreement between the operator and mesh network users). This is a linear programming problem, with closed, compact and convex constraint set [36]. Hence, it can be solved optimally in polynomial time.

6.4.1 Cost Sharing Policy

Each node of the mesh network will agree to cooperate in this offloading task only if she receives a fair portion of the net profit the network makes. The latter is determined from the payment of the operator, which is constant for a certain amount of offloaded traffic, minus the cost induced by serving this traffic. In game theoretic terms, the mesh nodes participate in a cooperative game with transferable utilities (TU game) [84], as the profit can be shared in an arbitrary fashion among them. In this game, each node decides whether to participate or not in the offloading service. This decision affects the servicing cost of the mesh network, as each participating node contributes new resources to the network and hence changes the solution space of the MFP problem.

In particular, we define the cooperative TU game $\mathcal{G}_M = (\mathcal{V}, I(\cdot))$ among the \mathcal{V} nodes of the mesh network, where $I : \mathcal{S} \rightarrow \mathbf{R}^+$ is the so-called *characteristic function* that assigns a positive scalar value to each coalition $\mathcal{S} \subseteq \mathcal{V}$. That is, each subset of nodes \mathcal{S} that decide to cooperate, achieves a net profit:

$$I(\mathcal{S}) = H_{op} - J(\mathbf{f}^*(\mathcal{S})), \quad (14)$$

where H_{op} is the payment of the operator, which is constant as long as the service offloads all the agreed traffic, and $\mathbf{f}^*(\mathcal{S})$ is the solution of the MFP problem when the subset \mathcal{S} of the mesh nodes participate in this task. The critical issue in this context is how the value of each coalition will be allocated to its members. In turn, this determines the coalitions that will be formed, i.e., which nodes will cooperate with each other. A particularly important question is whether the *grand coalition* $\mathcal{S} = \mathcal{V}$ will be formed and if it will be stable.

We employ the concept of Shapley value [33], which is an axiomatic fairness criterion, for allocating the profit among the mesh nodes. In detail, for each player v participating in a coalition $\mathcal{S} \subseteq \mathcal{V}$, the Shapley value $\phi_v(\mathcal{S}, I)$ is the

portion of the net profit that should be allocated to v . The Shapley value has certain desirable properties that render it self-enforcing [33], [84]. Moreover, there exists a closed form expression for finding this value for each player:

$$\phi_v(S, I) = \sum_{S \subset \mathcal{V}} \frac{|S|!(|\mathcal{V}| - |S| - 1)!}{|\mathcal{V}|!} (I(S \cup \{v\}) - I(S))$$

When the coalition game is super-additive and super-modular [84], then allocating the Shapley values to each player ensures that the grand coalition is formed and it is stable. That is, all nodes will participate in the offloading service and each one of them will receive a payment that is larger than his cost (in terms of energy consumption and Internet usage). Interestingly, the game \mathcal{G}_M poses both of these properties as it is stated in the following lemma:

Lemma 1. *The characteristic function $I(\cdot)$ of the game \mathcal{G}_M has the following properties:*

1. *It is superadditive, i.e.:*

$$I(\mathcal{S}_1 \cup \mathcal{S}_2) \geq I(\mathcal{S}_1) + I(\mathcal{S}_2), \forall \mathcal{S}_1, \mathcal{S}_2 \subset \mathcal{N}, \mathcal{S}_1 \cap \mathcal{S}_2 = \emptyset$$

2. *It is supermodular, i.e.:*

$$I(\mathcal{S} \cup \{v\}) - I(\mathcal{S}) \leq I(\mathcal{Q} \cup \{v\}) - I(\mathcal{Q}), \forall \mathcal{S} \subseteq \mathcal{Q} \subseteq \mathcal{V} \setminus \{v\}$$

Proof. The above properties are quite intuitive, as there is no participation cost for the mesh nodes, nor conflicting objectives among them. The detailed proof is given and simple to prove. The superadditivity property can be easily verified if we consider that cooperation does not entail any additional cost to the nodes, e.g., they do not have to buy additional equipment. Therefore, when two disjoint sets of nodes cooperate, in the worst case they can achieve the same performance of their previous disjoint operation.

Regarding the supermodularity property, we have the following:

$$I(\mathcal{S}) = H_{op} - J(\mathbf{f}^*(\mathcal{S})), I(\mathcal{S} \cup \{v\}) = H_{op} - J(\mathbf{f}^*(\mathcal{S} \cup \{v\}))$$

and

$$I(\mathcal{Q}) = H_{op} - J(\mathbf{f}^*(\mathcal{Q})), I(\mathcal{Q} \cup \{v\}) = H_{op} - J(\mathbf{f}^*(\mathcal{Q} \cup \{v\}))$$

Substituting the above to the definition of the supermodularity property, we get:

$$J(\mathbf{f}^*(\mathcal{S})) - J(\mathbf{f}^*(\mathcal{S} \cup \{v\})) \leq J(\mathbf{f}^*(\mathcal{Q})) - J(\mathbf{f}^*(\mathcal{Q} \cup \{v\}))$$

Table 8: LTE-A FDD System Configuration.

<i>Parameter</i>	<i>Value</i>	<i>Parameter</i>	<i>Value</i>
<i>Carrier Freq. fc</i>	1800 MHz	<i>max eNB TX Power</i>	20W [43dBm]
<i>Bandwidth</i>	10MHz	<i>Shadowing</i>	Log-normal
<i>Frame Duration</i>	10ms	<i>Fading</i>	Rayleigh
<i>T_{slot} / TTI</i>	0.5ms / 1ms	<i>Pathloss Model</i>	Hata Cost 231
<i>UEs</i>	40	<i>eNB Radius</i>	5km
<i>RBs per T_{slot}</i>	50	<i>eNB Height h_t</i>	50m
<i>RBs per TTI</i>	100	<i>UE Height h_r</i>	[1m-10m]
<i>Subcarriers per RB</i>	12	<i>Symbols per RB</i>	7

$$PL_{[dB]} = 46.3 + 33.9 \log_{10}(fc) - 13.82 \log_{10}(h_t) + (44.9 - (6.55 \log_{10}(h_t)) \log_{10}(d)) - \alpha(h_r) + C \quad (15)$$

$$\text{where } \alpha(h_r) = (1.1 \log_{10}(fc) - 0.7)h_r - (1.566 \log_{10}(fc) - 0.8)$$

$$\text{and } C = \begin{cases} 3 \text{ dB,} & \text{for metropolitan areas} \\ 0 \text{ dB,} & \text{for medium cities and suburban areas} \end{cases}$$

It is easy to see that the above inequality holds. The critical observation is the following. When optimizing the policy f for a larger mesh network, e.g., \mathcal{Q} , then the value of the minimum cost is upper bounded by the respective (minimum) cost for a smaller coalition \mathcal{S} plus the additional costs that incurred by \mathcal{S} for not having the additional resources that the nodes $\mathcal{Q} \setminus \mathcal{S}$ contribute to the network. Notice that any coalition can achieve the minimum cost of a smaller coalition by adopting exactly the same servicing policy. Moreover, the benefits from adding one more node to the network, increase with its size, as there are more options for exploiting the additional node resources. \square

6.5 PERFORMANCE EVALUATION

In this Section, we present: (i) the simulation results for the performance evaluation of the LTE-A cellular network that indicates how costly users are

offloaded, (ii) the testbed experimentation results and the assessment for the WiFi mesh network that will host the offloaded users, and (iii) the profit sharing results for the offloading monetary study.

6.5.1 LTE-A and WiFi Mesh Networks System Setup

LTE-Advanced Cellular Network Simulation: We consider an LTE-A FDD system for one eNB cell operating in 1800 MHz with an available bandwidth of 10 MHz. Table 8 summarizes the operational system characteristics. We assume the existence of 40 UEs that lie in the eNB's coverage area of a 5km radius. We have modeled the pathloss (PL) that each UE experiences in a metropolitan network topology, according to the Hata Cost 231 model [50]. Our assumption is aligned with the 3GPP adopted models for cellular network performance evaluation according to [22]. Moreover, we model slow shadow fading SH as log-normal with zero mean and a standard deviation of 8 dB. FD models a Rayleigh fast fading channel with a Doppler of 5 Hz. Therefore, the corresponding channel gains are derived according to $h = 10^{(SH+PL+FD)/10}$.

Every TTI the eNB takes a scheduling decision to dynamically assign the available time-frequency resources blocks (RBs) to the 40 UEs. The eNB scheduler aims at power efficient minimization while also at satisfying UEs demands (see problem def. in (5)). According to [57] the minimum size of radio resource that a scheduler can assign, is the minimum TTI in time domain which corresponds two 2 consecutive RBs. The size of each RB is the same for all bandwidths which is 180KHz. We assume that 90% of the available spectrum is effectively utilized for data-carrying and the rest 10% for pilot and guard signaling. Therefore the total number of data-carrying available RBs per T_{slot} (0.5ms) is $0.9 \frac{10MHz}{180KHz} = 50$ and per TTI (1ms) is 100. Every T subframes the eNB decides to offload the most power-consuming users, to the WiFi mesh network. We arbitrarily set $T = 20$ capturing the sparse time the eNB decides to offload. Given the problem definition in Eq. (5)-(8), the eNB needs to solve a mixed integer non-linear programming (MINLP) problem. For solving this NP-hard problem [80], we utilize OPTI [47], an embedded MATLAB optimization toolbox for attaining a feasible solution over the scheduling and power constraints.

Wireless Mesh Network Experimentation: In order to investigate the applicability of the proposed offloading approach in realistic environments, we deployed an indicative experimental setup in the NITOS indoor wireless testbed [13] for the wireless mesh part. NITOS nodes are equipped with both wireless and

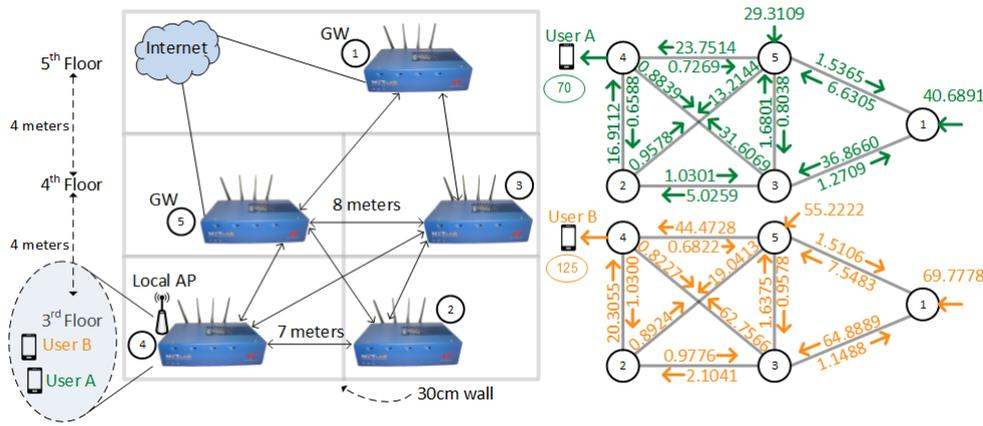

Figure 36: Wireless Mesh Experimentation Topology: (left) NITOS interior building testbed setup. (right) Optimal flows for mobile users A and B (Kbits).

wired network interfaces. We employed the wired interface to provide Internet access for the gateway nodes, while the Atheros 9380 wireless cards were used to implement the wireless mesh network. In Fig. 36, we illustrate the experimental topology, which spans three different floors of the same building. In order to provide for a clearer interpretation of the collected results in this basic experiment, we decided to fix the physical layer data bit rate equal to 12 Mbps for all the wireless adapters.

Based on the configured setup, we assess the maximum achievable throughput per link in the worst case scenario, which considers that all nodes constantly transmit saturated traffic to all their one-hop neighboring nodes. Application layer traffic was generated through the Iperf command [9]. Table 37 summarizes the gathered throughput capacities per link. Moreover, deriving of precise energy consumption results requires the collection of real time low level statistics per node, such as frame retransmissions. We managed to collect such information, by enabling the ath9k debugging option in the Ath9k driver [2]. Relying on the results of the work in [70], we estimated the energy consumption that the Atheros 9380 consumes while transmitting a single bit of information for all the available 802.11 a/g physical layer bit rates. Based on the above, we remark that when the AR9380 is configured to operate at 12 Mbps, it consumes $e^{\text{TX}} = 10.2083$ nJ/bit for transmission and $e^{\text{RX}} = 7.7083$ nJ/bit for reception.

Figure 37: Wireless Mesh Network Link Capacities (Kbps).

C_{vu}	①	②	③	④	⑤	AP
①	0	0	1445	0	1380	-
②	0	0	363	949	572	-
③	431	357	0	387	510	-
④	0	521	392	0	244	1000
⑤	290	225	211	211	0	-
GW	4000	-	-	-	2000	-

6.5.2 Experiments

LTE-A Network: In this simulation setup, we evaluate the power performance efficiency of an LTE eNB for servicing its associated users when offloading. The most costly users are those who require the greatest combination of power and resource allocation assignment during scheduling. As scheduling decisions are derived from the solution of the MINLP problem, the most costly users can be indicated directly, so as to be offloaded in nearby WiFi mesh networks. The total UEs demand saturates the LTE capacity for the period of $T = 20$ sub-frames. For a different number of offloading users, we illustrate in Fig. 38 the power saving costs for the eNB as the number of offloaded users increases. The eNBs' total power consumption (in one slot) for servicing 40 UEs is measured $P = 19.3308$ Watts. The saving in power consumption is expected to grow as the number of offloaded users increases. In addition, the average power consumption per servicing user reduces as this number decreases. An important finding is that the total gain remains high for a low number of offloaded users ($|\mathcal{N}_o| = 4$) while this gain remains low as the number of offloaded users increases. The rationale behind this is that as the eNB scheduler tends to select the most power consuming users to rid, the servicing users left can be characterized as less consuming and less power divergent. Fig. 39 illustrates the above finding showing the average power consumption per servicing user when offloading.

Wireless Mesh Network: For any user being served in a LTE cell, we must guarantee that her demands will be satisfied in an adequate time while toggling in the WiFi network. Although offloading can benefit eNBs and improve their efficiency due to power minimization, this must not degrade roughly the users experience. For two different users A and B being offloaded from the cellular network, we assess the servicing region of the mesh (see Fig. 40). It is impor-

tant to remark, that the servicing region illustrates the geometrical space of the feasible supported loads by the mesh network.

For various demands that lie within the servicing region, we solve the minimum cost flow optimization problem (Eq. 11) by using optimization software tools [47] and estimate the minimum incurred cost. Fig. 41 illustrates the solution evaluation. After the grey shaded line, there is no solution to guarantee the constraints in MFP. Moreover, for the two mobile users A and B being offloaded and requesting $D_A = 70$ and $D_B = 125$ Kbits accordingly, the optimal routing solution is also depicted in the right-side of Fig. 36 showing the amount of data transported through each link. (Recall that, for the sake of comparison that the number of subframes after when the eNB takes an offloading decision is $T = 20$ and the duration of each subframe is 1ms.) We measured the delay that each user experiences from the service in the WiFi mesh to be $d_A = 0.34155\text{ms}$ for the A and for user B $d_B = 0.56198\text{ms}$. The delay is less than and comparable to the TTI duration of 1ms that the eNB schedules the resources. However, the offloading decisions occur sparser in time and this implies that the wireless mesh operation can afford offloading. Notice that, depending on the value of T , it may be required to take fast policy decisions in the mesh network (e.g., in the scale of several seconds). This is currently easily implementable using software-defined networking (SDN) techniques which are available and have been already considered for routing in mesh networks [51].

Profit sharing: Offloading the most costly users from the cell network does not come as a free of charge service for the mobile operators. For the mesh users, in order to participate and aid in offloading process for servicing cellular users, a strong motivation is required, that is usually expressed in monetary gains. Operators compensate mesh users for their service with a fixed H_{op} payment that is stipulated upon agreement. At the end the mesh users should be motivated so as to continue participating in such a coalition. Therefore, mesh users are getting reimbursed for their service according to their provided effort and they share their profits relying on the Shapley values. In Table 9, we summarize the profit sharing values ϕ_i 's' for the mesh nodes that participate in such a coalition. We arbitrarily set $\alpha = 1$ and $p_u = 1$ to transform energy to monetary cost, for different values of H_{op} (virtual money) and aggregated user demands.

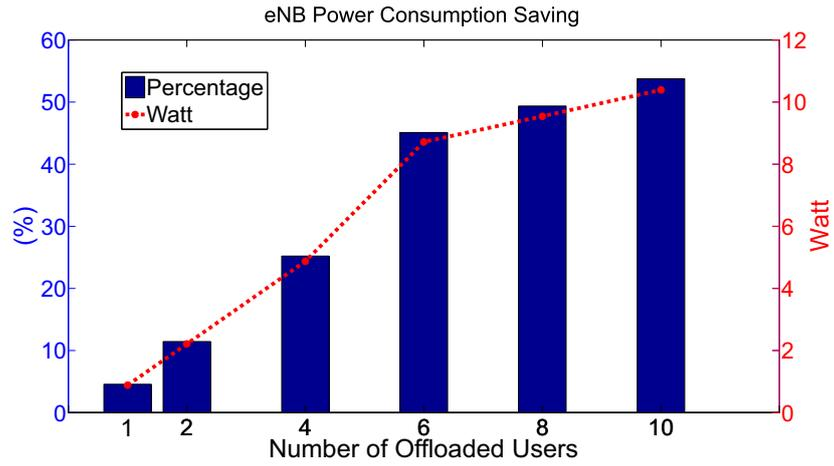

Figure 38: Offloading power consumption savings.

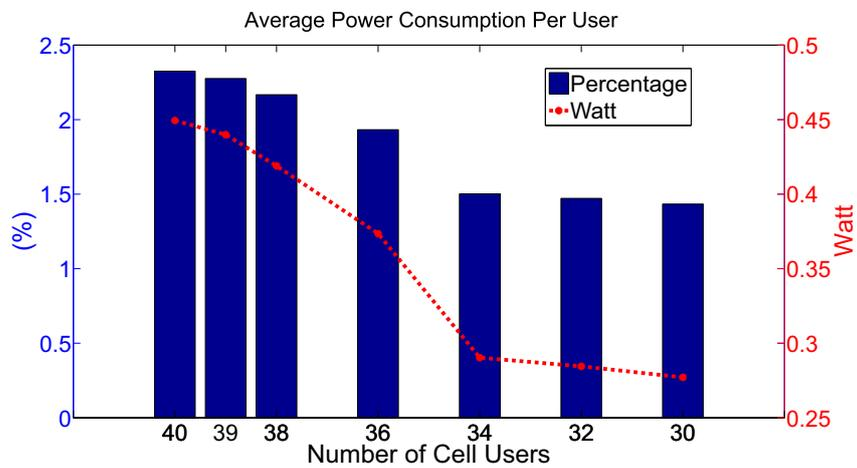

Figure 39: Power consumption per cellular user due to offloading.

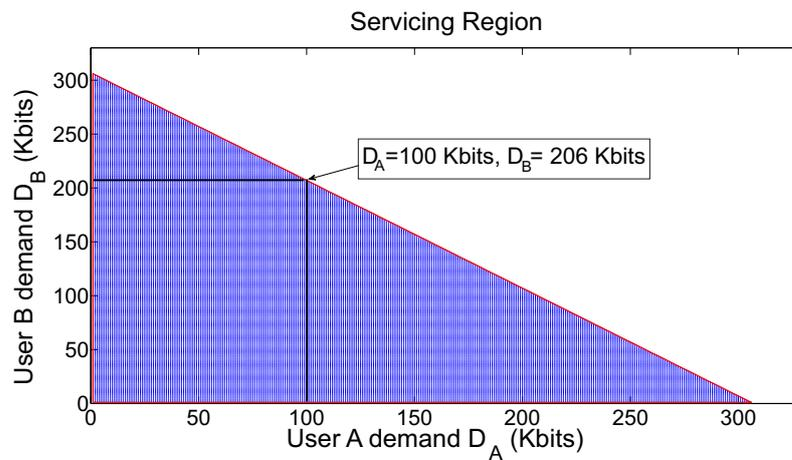

Figure 40: Mesh Network Servicing Region, for users A and B.

Figure 41: MFP Optimal Solution, $D_A = 10, D_B = [0, 206]$.

Table 9: Shapley Values: Profit Sharing.

<i>Demand</i>	<i>Payment Cost</i>		<i>Shapley Values</i>				
	H_{op}	$J(f^*(V))$	ϕ_1	ϕ_2	ϕ_3	ϕ_4	ϕ_5
$D_A + D_B$							
10 + 200	5000	2100	75	250	491.6	1525	558.4
10 + 200	10000	2100	325	500	1158.4	4275	1641.6
70 + 125	5000	1950	87.5	250	504.2	1612.5	595.8
70 + 125	10000	1950	337.5	500	1170.8	4362.5	1679.2
150 + 50	5000	2000	83.4	250	500	1583.2	583.4
150 + 50	10000	2000	333.4	500	1166.6	4333.4	1666.6

6.6 CONCLUSIONS

As the rapid proliferation of the 4G technology will not alleviate the ever-increasing demand for capacity, alternative solutions for heterogeneous networking interplay seem quite attractive. In this paper we presented a framework for cellular to mesh (C2M) offloading. Our approach captures the following aspects of the problem: (i) From the operators perspective, we determine the power costly users aiming at reducing the power consumption. (ii) From the wireless mesh perspective, we motivate the participation in an interplay with cellular networks for servicing offloaded users. Mesh user stimulation relies on the monetary compensation provided by the operator and the final fair profit sharing.

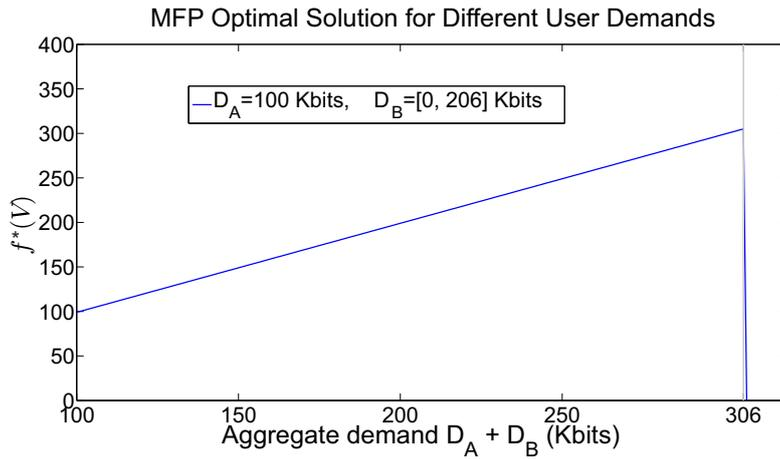
EPILOGUE

CONCLUSIONS AND FUTURE WORK

7.1 SUMMARY OF THE CONTRIBUTIONS

In this thesis, we have investigated testbed experimentation-based research in wireless networks. Our research is pertinent to the *design and implementation of resource allocation protocols*. Particularly, we rethink the standard operation of the contemporary wireless testbeds, in order to develop (deploy and evolve) a wireless testbed infrastructure characterized by a user-oriented twist. Our focus aimed at the provision of ease in the experimentation procedure that usually frightened and alienated non-advanced linux/systems users from real experimentation.

Moreover, we have proceeded in studying emerging topics in wireless networks: *Cooperative Relaying and Data Forwarding, as well as Mobile Data Offloading*. Our approach was not only based on concrete mathematical formulation and analysis relying on the optimization theory, but it was strengthened by real system implementations. Our initial motivation was the evaluation of the performance of the proposed techniques in real wireless networks, so as to prove their validity and ensure their applicability.

7.1.1 *Developing a wireless testbed framework to facilitate instrumental experimentation*

- We have introduced the notion of spectrum slicing so as to utilize wireless testbed efficiency.
- We have managed to incorporate a wireless testbed scheduler as a component of a well-known free-open source testbed managerial framework - OMF, in order to enable coordinated remote accessibility in a wireless testbed.

- We have implemented tools that can be utilized to support and assist researchers at different stages of their experimental study.
- We have proposed and implemented a Topology and Link Quality Assessment Protocol (TLQAP) to inspect link quality among the nodes of a wireless .
- We have utilized TLQAP inside a web-based link connectivity tool to facilitate wireless experimentation procedure and help researchers to find the topology that best fits their experimentation profile/description.

7.1.2 *Unleash the hidden potential of wireless communications through cooperative relaying and data forwarding*

- We have designed and implemented a TDMA access scheme for packet forwarding, which is backwards compatible with CSMA enabled commercial devices and it is also effectively applied upon Wi-Fi networks using off-the-shelf equipment.
- We have elaborated a centralized network controller in the TDMA frame to enforce scheduling and relay selection policies, relying on Lyapunov optimization.
- We have explore performance enhancements in terms of either throughput optimal or power efficient scheduling by implementing centralized networking.
- We have sought to obtain desired tradeoffs between networking performance efficiency metrics, such as power consumption (or system throughput) vs. networking delay.
- We have implemented the proposed centralized relay selection algorithm for Wi-Fi operational networks, by exploiting Open Source Software capabilities of the Click Router [72] and the Ath9k driver [2].
- We have achieved a *per packet* power and rate configuration by exploiting the *Radiotap header* [94].
- We have tested and evaluated our solution on the NITOS [13] wireless testbed.

- We have explored the potential applicability in WiMAX systems using a commercial Samsungs' System Level Simulator/Emulator.

7.1.3 *Evolve 5G Infrastructure for enabling disruptive future radio networks with relays*

- We have introduced an evolved user equipment (eUE) device to disrupt future 5G networks.
- We have identified particular scenarios where our proposed relaying architecture that elaborates eUE can be effectively utilized. We consider *moving cells* as well as *public safety* scenarios.
- We leverage eUEs so as to extend the network by building virtual links (VL) in order to provide access to core-isolated eNBs.
- We restore X2 air interface for interconnecting isolated eNBs by establishing virtual links with the aid of intermediate eUEs.
- We have considered cooperative relaying and L2/MAC forwarding, so as eUEs to restore the X2 air-interface in order to provide *reliable* and *low-latency* communication and as a consequence they become enablers for wireless multi-hop networking among eNBs.
- In small and/or dense cell scenarios, network and subsequently eNBs provide multiple data pipes to the eUEs through different radio bearers so as to increase their capacity.
- Software defined air interface and spectral usage techniques, including disruptive approaches for increasing network capacity and new wireless backhaul solutions
- We have implemented and tested the proposed architecture by using the OpenAirInterface platform.

7.1.4 *Wireless Data Offloading: To Disrupt Contemporary Wireless Communications*

- We have proposed a new architecture for offloading mobile data to collaborative mesh networks to alleviate cellular network traffic congestion by determining the power-costly users that need to be offloaded.
- We have introduced an optimization framework that can be used for calculating the cellular energy cost benefits, for each user, and the respective energy and Internet usage costs for the mesh network that admits the offloaded traffic.
- Our analysis can be utilized for different mesh network architectures.
- We provide a cost-sharing rule, based on the Shapley value, and prove that it ensures the participation of all the mesh nodes.
- We have evaluated the proposed offloading decision framework, using a detailed simulation analysis.
- We have conducted extensive experiments in an actual mesh network deployed in the NITOS testbed
- We measured the energy consumption costs and the perceived user performance in terms of experienced delay.
- We have investigated the cost savings of the operator when offloading user requests.
- We have designed a mechanism for dispensing the net benefit of the mesh network, i.e., the received compensation minus the servicing cost, among the mesh nodes

7.2 FUTURE WORK AND OPEN RESEARCH PROBLEMS

We conclude this thesis with a discussion of open research problems considering facilitating testbed experimentation based research as well as topics that are open and pertinent to resource allocation and scheduling schemes.

Facilitating Wireless Testbed Experimentation

Jourjon et al in [68] mention that experiments are a cornerstone of research in networking. Moreover, they ascertain that the experimental approaches that are used so far by the research community often suffer from shortcomings as inconsistency with widely adopted scientific methods, lack of proper replication, reproducibility and verifiability to support consistent and qualitative analysis of the obtained results. Moreover, *Collberg et al.* in [44] noticed the problem of the reproducibility in experimentation and tried to reproduce the results of significant published works in high quality conferences. Their stimulating motivation lied on the following fact that “only if my colleagues can reproduce my work should they trust its veracity. Excepting special cases, in applied Computer Science reproducing published work should be as simple as going to the authors’ website, downloading their code and data, typing “make” and seeing if the results correspond to the published ones”.

According to the above apparent observations, the actual problem is indeed that experimentation is conducted in an ad-hoc manner. Especially when custom-built or tailored software is used, the same experimentation setup can seldom be utilized or reproduced by third users. There are a lot of and diverse reasons for the above. Nevertheless, relying on the assumption that researchers are not willing to intentionally cheat, the common ground lies on the diversity of the tools, software and hardware versions that can become obsolete from time to time.

To this end an open research issue involves the design of an experimental methodology that will facilitate wireless testbed experimentation research at all stages. This would involve a sophisticated framework for experimentation where i.e. a user that is not interested to physical layer procedures to be able to experiment in higher layers and reproduce results from other experiments that might be useful to his experimentation, without facing any prohibitive or frustrating obstacles. Moreover, the researcher would be ideally submit a “description” of the specifications and the requirements of his/her experimentation and an intelligent agent would report a description of actions that he should consider, a mapping with the appropriate resources that he should reserve and steps that he should follow.

Cooperative Relaying and Data Forwarding in Wireless Mesh Networks

In the cooperative networks field, there exist a substantial number of research works where new schemes have been proposed to improve the communication

performance by using relays. But there are also several open issues still need to be solved.

An open challenge is the design and the implementation of an architecture that would adopt a holistic view in the resource allocation and scheduling and potentially combine signal and packet level cooperation and relaying. Cross-layer techniques are leveraged to optimize critical parameters which are closely dependent to each other, affect the systems performance almost mutually and they are located on different layers of the protocol stack. A holistic view can radically rethink the above understanding and can enhance the network operation considering signal and packet level cooperation interplays. A holistic architecture can represent the communication performance achieved in one layer to other layers with particular performance metrics such as error probabilities or delays. Those metrics constitute valuable information that is propagated throughout the layers in order to enable ambient adaptation and self-organization. Enabling efficient cooperative networking involves also advanced spectrum and frequency management techniques, perceptual scheduling and sensitive delay management in cases of different types of information (video, voice, raw data) as well as incentives provisioning to motivate users to participate in data forwarding and cooperative relaying.

Mobile Data Offloading

We have investigated mobile data offloading from an energy saving perspective. Various ramifications of the above problem include also throughput and delay perspectives. However, the most challenging is the enabling of an end-to-end principle such that the user toggling from cellular to wireless mesh to be performed seamlessly.

Moreover, integrating an effective incentive scheme to encourage active social participation is of paramount importance in cellular to mesh mobile data offloading so as to alleviate the problem of increased traffic congestion. In addition, the monetary reimbursement that is dispensed to wireless mesh network users is an attractive motivation that stimulates participation. However, what will be the cost for the cellular carriers if wireless mesh networks realize their potential and not only absorb traffic from cellular networks but also initiate to offer alternate routing through their network with direct charges to mobile users. Issues related to pricing and billing models for rational traffic offloading between cellular carriers and WiFi mesh users or operators still remain open.

Part III

APPENDIX

APPENDIX TEST

A.1 LYAPUNOV OPTIMIZATION ANALYSIS

Let the system state be $\Theta(t) = Q(t)$. The Lyapunov function that describes the aggregate network congestion is the sum of squares of queue backlogs $L(\Theta(t)) \equiv \frac{1}{2}\Theta(t)^2 \equiv \frac{1}{2}Q(t)^2$. and the corresponding Lyapunov drift is given by:

$$\Delta(t) = \mathbf{E}[L(\Theta(t+1)) - L(\Theta(t))|\Theta(t)] \quad (16)$$

The Lyapunov drift plus *penalty* expression is bounded by the following inequality:

$$\begin{aligned} \Delta(t) + V \mathbf{E}\{\mathbf{p}(t)\} &\leq B|\mathcal{N}| + \sum_i Q_i(t)\lambda_i \\ &+ \sum_i Q_i(t) \left(\sum_a \hat{\mu}_{ai}(\mathbf{a}(t)) - \sum_b \hat{\mu}_{bi}(\mathbf{a}(t)) \right) + V \mathbf{E}\{\hat{\mathbf{p}}(\mathbf{a}(t))\}, \end{aligned} \quad (17)$$

Let $\hat{\mathbf{p}}(\mathbf{a}(t))$ be a controllable penalty function of power consumption that depends on the system controller $\mathbf{a}(t)$ and it is equal to $\hat{\mathbf{p}}(\mathbf{a}(t)) = \mathbf{a}(t)[P_{SR_1}(t) + P_{R_2D}] + (1 - \mathbf{a}(t))[P_{SR_2}(t) + P_{R_1D}]$. For the wireless diamond network of Fig. 16 the Lyapunov drift plus penalty expression with the objective of power performance optimization is described by Eq. (18). Observe that only source node S has an exogenous traffic inserted, so we only consider λ_S and for the rest nodes $\lambda_{R_1} = \lambda_{R_2} = \lambda_D = 0$ are equals to zero.

$$\begin{aligned} \Delta(t) + V \mathbf{E}\{\mathbf{p}(t)\} &\leq BN + Q_S(t)\lambda_S + V\{ \mathbf{a}(t)[P_{SR_1}(t) \\ &+ P_{R_2D}(t)] + (1 - \mathbf{a}(t))[P_{SR_2}(t) + P_{R_1D}(t)] \} \\ &- Q_S(t) [\mathbf{a}(t)\mu_{SR_1}(t) + (1 - \mathbf{a}(t))\mu_{SR_2}(t)] \\ &- Q_{R_1}(t)(1 - \mathbf{a}(t))\mu_{R_1D}(t) - Q_{R_2}(t)\mathbf{a}(t)\mu_{R_2D}(t) \\ &+ Q_{R_1}(t)\mathbf{a}(t)\mu_{SR_1}(t) + Q_{R_2}(t)(1 - \mathbf{a}(t))\mu_{SR_2}(t), \end{aligned} \quad (18)$$

where $B = (A_i(t))^2 + (\sum_a \mu_{ai}(t))^2 + (\sum_b \mu_{ib}(t))^2 + 2A_i(t) \sum_a \mu_{ai}(t)$ and $\lambda_i = \mathbf{E}\{A_i(t)\}$. Transmission rate $\hat{\mu}_{a,b}(\mathbf{a}(t))$ is also a controllable system pa-

parameter that depends on the system controller $\mathbf{a}(t)$ each time slot t . Moreover, it holds that $\hat{\mu}_{ab}(\mathbf{a}(t)) = a(t)\mu_{ab}(t)$ and $\hat{\mu}_{ab}(\mathbf{a}(t)) = (1 - a(t))\mu_{ab}(t)$, if $(ab) \in \{SR_1, R_2D\}$ and if $(ab) \in \{SR_2, R_1D\}$ respectively.

BIBLIOGRAPHY

- [1] Affix. URL <https://affix.poly.edu/projects/project>.
- [2] Ath9k debugging. URL <http://wireless.kernel.org/en/users/Drivers/ath9k/debug/>.
- [3] Bewifi. URL <http://www.bewifi.es//>.
- [4] cfg80211 - Linux Wireless. URL <http://wireless.kernel.org/en/developers/Documentation/cfg80211>.
- [5] EU-FP7 Confine. URL <http://confine-project.eu/>.
- [6] CRDA - Linux Wireless. URL <http://wireless.kernel.org/en/developers/Regulatory/CRDA>.
- [7] <http://www.emulab.net/>.
- [8] Fon. URL <http://fon.com/>.
- [9] Iperf. URL <http://iperf.fr/>.
- [10] OAI svn repository for implementation of L2 packet forwarding. <https://svn.eurecom.fr/openairsvn/openair4G/branches/loamesh>.
- [11] <http://madwifi.org/>.
- [12] UTH NITLab. <http://nitlab.inf.uth.gr>, .
- [13] Nitos wireless testbed, . URL <http://nitlab.inf.uth.gr//>.
- [14] <http://nitlab.inf.uth.gr/>, .
- [15] OneLab2. URL <http://www.onelab.eu/>.
- [16] Open garden. URL <https://opengarden.com//>.
- [17] Physical layer - general description, 3GPP TS 25.201 V11.1.0. Technical Specification.
- [18] <http://www.planet-lab.org/>.

- [19] Relay architectures for E-UTRA (LTE-Advanced), 3GPP TR 36.806 Vo.2.0. Technical Specification.
- [20] <http://www.winlab.rutgers.edu/>.
- [21] Wireless-Extensions - Linux Wireless. URL <http://wireless.kernel.org/en/developers>.
- [22] *Technical Specification Group Radio Access Network, Spatial channel model for Multiple Input Multiple Output (MIMO) simulations*. 3GPP TR 25.996 V11.0.0, 9 2012.
- [23] *Technical Specification Group Core Network and Terminals, Access Network Discovery and Selection Function (ANDSF) Management Object (MO)*. 3GPP TS 24.312 V12.3.0, 2013.
- [24] Study on impact of traffic off-loading and related technological trends on the demand for wireless broadband spectrum. *European Commission, Directorate-General for Communications Networks, Content and Technology*, 2013. doi: 10.1109/MCOM.2011.5783985.
- [25] Angelos Anadiotis, Apostolos Apostolaras, Thanasis Korakis, and Leandros Tassiulas. A new scheme for slicing over experimental wireless testbeds. Technical report, University of Thessaly, 2009.
- [26] Jeffrey G. Andrews, Sarabjot Singh, Qiaoyang Ye, Xingqin Lin, and Harpreet S. Dhillon. An overview of load balancing in hetnets: Old myths and open problems. *CoRR*, 2013.
- [27] J.G. Andrews. Seven ways that hetnets are a cellular paradigm shift. *Comm. Magazine, IEEE*, 2013. ISSN 0163-6804. doi: 10.1109/MCOM.2013.6476878.
- [28] Angelos-Christos Anadiotis, Apostolos Apostolaras, Dimitris Syrivelis, Thanasis Korakis, Leandros Tassiulas, Luis R. Rodriguez, Ivan Seskar, Maximilian Ott. A Demonstration of a Slicing Scheme for Efficient Use of Testbed's Resources. Demo, Mobicom 2009, September 2009.
- [29] Angelos-Christos Anadiotis, Apostolos Apostolaras, Dimitris Syrivelis, Thanasis Korakis, Leandros Tassiulas, Luis R. Rodriguez, Maximilian Ott. A New Slicing Scheme for Efficient Use of Wireless Testbeds. In *Proceedings of the 4th ACM international workshop on Experimental evaluation and characterization*, 2009.

- [30] Apostolos Apostolaras, Kostas Choumas, Ilias Syrigos, Iordanis Koutsopoulos, Thanasis Korakis, Antonios Argyriou, and Leandros Tassiulas. On the Implementation of Relay Selection Strategies for a Cooperative Diamond Network. In *PIMRC 2013*, in Proc. of .
- [31] Apostolos Apostolaras, Kostas Choumas, Ilias Syrigos, Giannis Kazdaridis, Thanasis Korakis, Iordanis Koutsopoulos, Antonios Argyriou, and Leandros Tassiulas. A Demonstration of a Relaying Selection Scheme for Maximizing a Diamond Network's Throughput. In *TRIDENTCOM*, pages 408–410, 2012.
- [32] O. Arnold, F. Richter, G. Fettweis, and O. Blume. Power consumption modeling of different base station types in heterogeneous cellular networks. In *Future Network and Mobile Summit, 2010*, June 2010.
- [33] RJ Aumann and LS Shapley. Values of non-atomic games. 1974.
- [34] Bilel Ben Romdhanne, Navid, Nikaein, Knopp Raymond, and Bonnet Christian. OpenAirInterface large-scale wireless emulation platform and methodology. In *ACM PM2HW2N*, 2011.
- [35] M. Bennis, M. Simsek, A. Czylik, W. Saad, S. Valentin, and M. Debbah. When cellular meets wifi in wireless small cell networks. *Communications Magazine, IEEE*, 51(6):44–50, 2013. ISSN 0163-6804. doi: 10.1109/MCOM.2013.6525594.
- [36] Dimitri P Bertsekas. *Nonlinear Programming*. Athena Scientific, 1999.
- [37] John Bicket, Daniel Aguayo, Sanjit Biswas, and Robert Morris. Architecture and evaluation of an unplanned 802.11b mesh network. *ACM MobiCom*, pages 31–42, 2005.
- [38] John Bicket, Daniel Aguayo, Sanjit Biswas, and Robert Morris. Architecture and evaluation of an unplanned 802.11b mesh network. In *MobiCom '05: Proceedings of the 11th annual international conference on Mobile computing and networking*, 2005.
- [39] Brent N. Chun, Philip Buonadona, Alvin AuYoung, Chaki Ng, David C. Parkes, Jeffrey Schneidman, Alex C. Snoeren, Amin Vehdat. Mirage: A Microeconomic Resource Allocation System for SensorNet Testbeds.
- [40] Ioannis Broustis, Jakob Eriksson, S. V. Krishnamurthy, and Michalis Faloutsos. A blueprint for a manageable and affordable wireless testbed: Design, pitfalls and lessons learned. In *IEEE International Conference on*

Testbeds and Research Infrastructures for the Development of Networks and Communities.

- [41] S. Chiochan and E. Hossain. Cooperative relaying in wi-fi networks with network coding. *Wireless Communications, IEEE*, 19(2):57–65, april 2012. ISSN 1536-1284.
- [42] Youngkyu Choi and Sunghyun Choi. Service charge and energy-aware vertical handoff in integrated iee 802.16 e/802.11 networks. In *INFO-COM*, 2007.
- [43] A.M. Cipriano, P. Agostini, A. Blad, and R. Knopp. Cooperative communications with harq in a wireless mesh network based on 3gpp lte. In *EUSIPCO*, 2012.
- [44] Christian Collberg, Todd Proebsting, Gina Moraila, Akash Shankaran, Zuoming Shi, and Alex M Warren. Measuring reproducibility in computer systems research. Technical report, March 2014. URL <http://reproducibility.cs.arizona.edu/tr.pdf>.
- [45] Douglas S. J. De Couto, Robert Morris, Daniel Aguayo, and John Bicket. A high-throughput path metric for multi-hop wireless routing. *Wireless Networking*, 11(4), 2005.
- [46] T. Cover and A.E. Gamal. Capacity Theorems for the Relay Channel. *Information Theory, IEEE Transactions on*, 25, Sep 1979. ISSN 0018-9448.
- [47] Jonathan Currie and David I Wilson. Opti: lowering the barrier between open source optimizers and the industrial matlab user. *Foundations of Computer-Aided Process Operations, Savannah, Georgia, USA*, 2012.
- [48] D. Raychaudhuri, I. Seskar, M. Ott, S. Ganu, K. Ramachandran, H. Kremo, R. Siracusa, H. Liu, M. Singh. “Overview of the ORBIT Radio Grid Testbed for Evaluation of Next-Generation Wireless Network Protocols.
- [49] A. Damnjanovic, J. Montojo, Yongbin Wei, Tingfang Ji, Tao Luo, M. Vajapeyam, Taesang Yoo, Osok Song, and D. Malladi. A survey on 3gpp heterogeneous networks. *Wireless Comm., IEEE*, 2011. ISSN 1536-1284. doi: 10.1109/MWC.2011.5876496.
- [50] Eraldo Damosso and Luis M Correia. *COST Action 231: Digital Mobile Radio Towards Future Generation Systems: Final Report*. EU, 1999.
- [51] A. Detti, C. Pisa, S. Salsano, and N. Blefari-Melazzi. Wireless mesh software defined networks (wmsdn). In *WiMob*, 2013.

- [52] S. Dimatteo, Pan Hui, Bo Han, and V.O.K. Li. Cellular traffic offloading through wifi networks. In *Mobile Adhoc and Sensor Systems (MASS), 2011 IEEE 8th International Conference on*, Oct 2011.
- [53] Richard Draves, Jitendra Padhye, and Brian Zill. Routing in multi-radio, multi-hop wireless mesh networks. In *MobiCom '04: Proceedings of the 10th annual international conference on Mobile computing and networking*. ACM, 2004.
- [54] Melissa Duarte, Ayan Sengupta, Siddhartha Brahma, Christina Fragouli, and Suhas Diggavi. Quantize-map-forward (qmf) relaying: An experimental study. In *Proceedings of the Fourteenth ACM International Symposium on Mobile Ad Hoc Networking and Computing, MobiHoc '13*, pages 227–236, New York, NY, USA, 2013. ACM. ISBN 978-1-4503-2193-8. doi: 10.1145/2491288.2491307. URL <http://doi.acm.org/10.1145/2491288.2491307>.
- [55] Mesut Ali Ergin and Marco Gruteser. Using packet probes for available bandwidth estimation: a wireless testbed experience. In *WiNTECH '06: Proceedings of the 1st international workshop on Wireless network testbeds, experimental evaluation & characterization*. ACM.
- [56] L. Georgiadis, M. J. Neely, and L. Tassiulas. *Resource Allocation and Cross-layer Control in Wireless Networks*. Foundations and Trends in Networking, 2006.
- [57] A. Ghosh, J. Zhang, J.G. Andrews, and R. Muhamed. *Fundamentals of LTE*. Prentice Hall Communications Engineering and Emerging Technologies Series. 2010. ISBN 9780137033898.
- [58] L. Gkatzikis and I. Koutsopoulos. Low complexity algorithms for relay selection and power control in interference-limited environments. In *Modeling and Optimization in Mobile, Ad Hoc and Wireless Networks (WiOpt), 2010 Proceedings of the 8th International Symposium on*, pages 278 –287, 31 2010-june 4 2010.
- [59] Zhangyu Guan, Tommaso Melodia, Dongfeng Yuan, and Dimitris A. Pados. Distributed Spectrum Management and Relay Selection in Interference-limited Cooperative Wireless Networks. *MobiCom '11*, pages 229–240. ACM, 2011. ISBN 978-1-4503-0492-4. doi: 10.1145/2030613.2030639.
- [60] P. Gupta and P.R. Kumar. The capacity of wireless networks. *Information Theory, IEEE Transactions on*, 2000. ISSN 0018-9448.

- [61] Sangtae Ha, Soumya Sen, Carlee Joe-Wong, Youngbin Im, and Mung Chiang. Tube: Time-dependent pricing for mobile data. SIGCOMM '12, pages 247–258, New York, NY, USA, 2012. ACM. ISBN 978-1-4503-1419-0. doi: 10.1145/2342356.2342402. URL <http://doi.acm.org/10.1145/2342356.2342402>.
- [62] H. Halabian, I. Lambadaris, Chung-Horng Lung, and A. Srinivasan. Throughput-optimal relay selection in multiuser cooperative relaying networks. In *MILITARY COMMUNICATIONS CONFERENCE, 2010 - MILCOM 2010*, pages 507–512, 31 2010-nov. 3 2010.
- [63] Cisco Visual Networking Index. Global mobile data traffic forecast update, 2012–2017, cisco white paper, feb. 6, 2013, .
- [64] Cisco Visual Networking Index. Global mobile data traffic forecast update, 2013–2018, cisco white paper, feb. 5, 2014, .
- [65] G. Iosifidis, Lin Gao, Jianwei Huang, and L. Tassiulas. An iterative double auction for mobile data offloading. In *Modeling Optimization in Mobile, Ad Hoc Wireless Networks (WiOpt), 2013 11th International Symposium on*, May 2013.
- [66] Mikio Iwamura, Hideaki Takahasi, and Satoshi Nagata. Relay technology in lte-advanced. *Ongoing Evolution of LTE toward IMT-Advanced, NTT Docomo Journal*.
- [67] Yindi Jing and B. Hassibi. Distributed space-time codes in wireless relay networks. In *Sensor Array and Multichannel Signal Processing Workshop Proc.*, 2004.
- [68] Guillaume Jourjon, Thierry Rakotoarivelo, and Max Ott. A portal to support rigorous experimental methodology in networking research. In *7th International ICST Conference on Testbeds and Research Infrastructures for the Development of Networks and Communities (Tridentcom)*, page 16, Shanghai, China, April 2011.
- [69] Y. Yi K. Son, H. Kim and B. Krishnamachari. *Green Communications: Theoretical Fundamentals, Algorithms and Applications*. 2012. ISBN 1466501073, 9781466501072.
- [70] Stratos Keranidis, Giannis Kazdaridis, Virgilios Passas, Thanasis Korakis, Iordanis Koutsopoulos, and Leandros Tassiulas. Nitos energy monitoring framework: real time power monitoring in experimental wireless net-

- work deployments. *ACM SIGMOBILE Mobile Computing and Communications Review*, 2014.
- [71] Murali Kodialam and Thyaga Nandagopal. Characterizing the capacity region in multi-radio multi-channel wireless mesh networks. In *In proc. Mobicom*, 2005.
- [72] Eddie Kohler, Robert Morris, Benjie Chen, John Jannotti, and M. Frans Kaashoek. The click modular router. *ACM Trans. Comput. Syst.*, August 2000.
- [73] Eddie Kohler, Robert Morris, Benjie Chen, John Jannotti, and M. Frans Kaashoek. The click modular router. *ACM Transactions on Computer Systems*, 2000.
- [74] C.E. Koksal and H. Balakrishnan. Quality-aware routing metrics for time-varying wireless mesh networks. *IEEE Selected Areas In Communications*, 2006.
- [75] Thanasis Korakis, Zhifeng Tao, Salik Makda, Boris Gitelman, and Shivendra Panwar. It Is Better to Give Than to Receive: Implications of Cooperation in a Real Environment. In *Proc. of IFIP-TC6 conf., NETWORKING'07*, 2007.
- [76] Thanasis Korakis, Zhifeng Tao, ShashiRaj Singh, Pei Liu, and Shivendra Panwar. Implementation of a Cooperative MAC Protocol: Performance and Challenges in a Real Environment. *EURASIP Wireless Comm. and Networking Journal*, 2009. ISSN 1687-1499. doi: 10.1155/2009/598140.
- [77] Rafael Laufer, Theodoros Salonidis, Henrik Lundgren, and Pascal Le Guyadec. XPRESS: a Cross-layer Backpressure Architecture for Wireless Multi-hop Networks. *MobiCom '11*, pages 49–60. ACM, 2011. ISBN 978-1-4503-0492-4.
- [78] Kyunghan Lee, Joohyun Lee, Yung Yi, Injong Rhee, and Song Chong. Mobile data offloading: How much can wifi deliver? In *in Proc., CO-NEXT*, 2010.
- [79] Pei Liu, Zhifeng Tao, Sathya Narayanan, Thanasis Korakis, and Shivendra S. Panwar. CoopMAC: A Cooperative MAC for Wireless LANs. *Selected Areas in Communications, IEEE Journal*, 25(2):340–354, February 2007. ISSN 0733-8716.

- [80] Ya-Feng Liu and Yu-Hong Dai. On the complexity of joint subcarrier and power allocation for multi-user ofdma systems. *Signal Processing, IEEE Transactions on*, 2014. ISSN 1053-587X.
- [81] D. Lopez-Perez, A. Ladanyi, A. Juttner, H. Rivano, and Jie Zhang. Optimization method for the joint allocation of modulation schemes, coding rates, resource blocks and power in self-organizing lte networks. In *INFOCOM, 2011 Proceedings IEEE*, April 2011.
- [82] R. Madan, N. Mehta, A. Molisch, and Jin Zhang. Energy-Efficient Cooperative Relaying over Fading Channels with Simple Relay Selection. *Wireless Communications, IEEE Transactions on*, 7, Aug. 2008. ISSN 1536-1276.
- [83] J. McNair and Fang Zhu. Vertical handoffs in fourth-generation multi-network environments. *Wireless Communications, IEEE*, 2004. ISSN 1536-1284.
- [84] Roger B Myerson. *Game theory: analysis of conflict*. Harvard University, 1991.
- [85] M. J. Neely. *Stochastic Network Optimization with Application to Communication and Queueing Systems*. Morgan & Claypool Publishers, 2010.
- [86] M.J. Neely. Energy Optimal Control for Time Varying Wireless Networks. In *INFOCOM*, volume 1, March 2005.
- [87] Chun Nie, Pei Liu, T. Korakis, E. Erkip, and S.S. Panwar. Cooperative relaying in next-generation mobile wimax networks. *Vehicular Technology, IEEE Trans. on*, 2013. ISSN 0018-9545. doi: 10.1109/TVT.2012.2230281.
- [88] V. Nikolyenko and L. Libman. Coop80211: Implementation and Evaluation of a SoftMAC-based Linux Kernel Module for Cooperative Retransmission. In *WCNC, 2011 IEEE*, pages 239–244, March 2011.
- [89] F. Pantisano, M. Bennis, W. Saad, M. Debbah, and M. Latva-aho. On the impact of heterogeneous backhalls on coordinated multipoint transmission in femtocell networks. In *IEEE ICC*, 2012. doi: 10.1109/ICC.2012.6364418.
- [90] S. Paris, F. Martignon, I. Filippini, and Lin Chen. A bandwidth trading marketplace for mobile data offloading. In *IEEE INFOCOM*, 2013.

- [91] Steven W. Peters, Ali Y. Panah, Kien T. Truong, and Robert W. Heath. Relay architectures for 3gpp lte-advanced. *EURASIP J. Wirel. Commun. Netw.*, 2009:1:1–1:14, March 2009. ISSN 1687-1472.
- [92] Qualcomm. The 1000x data challenge. <http://www.qualcomm.com/solutions/wireless-networks/technologies/1000x-data>.
- [93] R. Mahindra, G. D. Bhanage, G. Hadjichristofi, I. Seskar, D. Raychaudhuri, Y.Y. Zhang. Space Versus Time Separation For Wireless Virtualization On An Indoor Grid.
- [94] Radiotap. The Radiotap Header for 802.11 Frame Injection and Reception. URL <http://www.radiotap.org>.
- [95] D. Raychaudhuri, I. Seskar, M. Ott, S. Ganu, K. Ramachandran, H. Kremo, R. Siracusa, H. Liu, and M. Singh. Overview of the orbit radio grid testbed for evaluation of next-generation wireless network protocols. In *IEEE Wireless Communications and Networking Conference (WCNC 2005)*.
- [96] N. Ristanovic, J.-Y. Le Boudec, A. Chaintreau, and V. Erramilli. Energy efficient offloading of 3g networks. In *Mobile Adhoc and Sensor Systems (MASS), 2011 IEEE 8th International Conference on*.
- [97] I. Toufik S. Sesia and M. Baker. *The UMTS Long Term Evolution - From Theory to Practice*. 2011.
- [98] B. Schein and R. Gallager. The Gaussian Parallel Relay Network. In *Information Theory, Proc. IEEE International Symposium on*, 2000.
- [99] S. Sen, C. Joe-Wong, Sangtae Ha, and Mung Chiang. Incentivizing time-shifting of data: a survey of time-dependent pricing for internet access. *Communications Magazine, IEEE*, 50(11):91–99, November 2012. ISSN 0163-6804. doi: 10.1109/MCOM.2012.6353688.
- [100] A. Sendonaris, E. Erkip, and B. Aazhang. User cooperation diversity. part i & ii. implementation aspects and performance analysis. *Communications, IEEE Trans. on*, 2003. ISSN 0090-6778. doi: 10.1109/TCOMM.2003.819238.
- [101] Stefania Sesia, Issam Toufik, and Matthew Baker. *LTE - The UMTS Long Term Evolution*. John Wiley & Sons, Ltd, 2009. ISBN 9780470742891.
- [102] Standard. 802.11-2012 - IEEE Standard for Information Technology, Wireless LAN Medium Access Control (MAC) and Physical Layer (PHY) Specifications.

- [103] Yutao Sui, J. Vihriala, A. Papadogiannis, M. Sternad, Wei Yang, and T. Svensson. Moving cells: a promising solution to boost performance for vehicular users. *Communications Magazine, IEEE*, 51(6):62–68, 2013. ISSN 0163-6804. doi: 10.1109/MCOM.2013.6525596.
- [104] Dimitris Syrivelis, Angelos-Christos Anadiotis, Apostolos Apostolaras, Thanasis Korakis, and Leandros Tassiulas. TLQAP: a Topology and Link Quality Assessment Protocol for Efficient Node Allocation on Wireless Testbeds. In *Proceedings of the 4th ACM international workshop on Experimental evaluation and characterization, WINTECH '09*, pages 27–34, New York, NY, USA, 2009. ACM. ISBN 978-1-60558-740-0. doi: 10.1145/1614293.1614299. URL <http://doi.acm.org/10.1145/1614293.1614299>.
- [105] L. Tassiulas and A. Ephremides. Stability Properties of Constrained Queueing Systems and Scheduling Policies for Maximum Throughput in Multihop Radio Networks. *Automatic Control, IEEE Trans.*, 1992. ISSN 0018-9286. doi: 10.1109/9.182479.
- [106] Tcpdump/Libpcap. The Official Website of tcpdump, a Powerfull Command-line Packet Analyzer; and Libpcap, a Portable C/C++ Library for Network Traffic Capture. <http://www.tcpdump.org/>.
- [107] Oumer Teyeb, Vinh Van Phan, Bernhard Raaf, and Simone Redana. Dynamic relaying in 3gpp lte-advanced networks. *EURASIP J. Wirel. Commun. Netw.*, 2009:6:1–6:1, March 2009. ISSN 1687-1472. doi: 10.1155/2009/731317. URL <http://dx.doi.org/10.1155/2009/731317>.
- [108] Jean Tourrilhes. Wireless Extensions for Linux. URL <http://www.hpl.hp.com/personal/JeanTourrilhes>.
- [109] A. Tyrrell, G. Auer, and C. Bettstetter. Fireflies as role models for synchronization in ad hoc networks. In *Bio-Inspired Models of Network, Information and Computing Systems, 2006. 1st*, pages 1–7, Dec 2006. doi: 10.1109/BIMNICS.2006.361799.
- [110] E. C. van der Meulen. Three-Terminal Communication Channels. *Adv. Appl. Probab.*, 3:120–154, 1971.
- [111] Wireshark. The World's Foremost Network Packet Analyzer. <http://www.wireshark.org/>.
- [112] Yang Yang, Honglin Hu, Jing Xu, and Guoqiang Mao. Relay technologies for wimax and lte-advanced mobile systems. *Comm. Magazine, IEEE*, 2009. ISSN 0163-6804. doi: 10.1109/MCOM.2009.5273815.

- [113] Edmund Yeh and Randall Berry. Throughput Optimal Control of Wireless Networks with Two-hop Cooperative Relaying. In *Information Theory, 2007. ISIT 2007. IEEE International Symposium on*, pages 351–355, June 2007.
- [114] E.M. Yeh and R.A. Berry. Throughput Optimal Control of Cooperative Relay Networks. *Information Theory, IEEE Transactions*, Oct. 2007. ISSN 0018-9448.
- [115] Jin Zhang and Qian Zhang. Stackelberg Game for Utility-based Cooperative Cognitive Radio Networks. *MobiHoc '09*, pages 23–32. ACM, 2009. ISBN 978-1-60558-624-3. doi: 10.1145/1530748.1530753.
- [116] Jian Zhao, T.Q.S. Quek, and Zhongding Lei. Coordinated multipoint transmission with limited backhaul data transfer. *Wireless Comm, IEEE Trans*, 2013. ISSN 1536-1276. doi: 10.1109/TWC.2013.050613.120825.