

ΠΑΝΕΠΙΣΤΗΜΙΟ ΘΕΣΣΑΛΙΑΣ

ΠΟΛΥΤΕΧΝΙΚΗ ΣΧΟΛΗ

ΤΜΗΜΑ ΜΗΧΑΝΟΛΟΓΩΝ ΜΗΧΑΝΙΚΩΝ ΒΙΟΜΗΧΑΝΙΑΣ

Διατριβή

**ΒΕΛΤΙΣΤΟΠΟΙΗΣΗ ΠΡΟΓΡΑΜΜΑΤΙΣΜΟΥ ΠΑΡΑΓΩΓΗΣ ΚΑΙ
ΔΙΑΝΟΜΗΣ ΠΡΟΪΟΝΤΩΝ ΣΕ ΧΗΜΙΚΗ ΒΙΟΜΗΧΑΝΙΑ
ΡΗΤΙΝΗΣ ΡΕΤ**

υπό

ΟΛΥΜΠΙΑΣ ΧΑΤΖΗΚΩΝΣΤΑΝΤΙΝΟΥ

Διπλωματούχου Μηχανολόγου και Αεροναυπηγού Μηχανικού Πανεπιστημίου Πατρών, 2005
Μ.Δ.Ε. Μηχανολόγου Μηχανικού Πανεπιστημίου Θεσσαλίας, 2009

Υπεβλήθη για την εκπλήρωση μέρους των

απαιτήσεων για την απόκτηση του

Διδακτορικού Διπλώματος

2009

© 2009 Ολυμπία Χατζηκωνσταντίνου

Η έγκριση της διδακτορικής διατριβής από το Τμήμα Μηχανολόγων Μηχανικών της Πολυτεχνικής Σχολής του Πανεπιστημίου Θεσσαλίας δεν υποδηλώνει αποδοχή των απόψεων του συγγραφέα (Ν. 5343/32 αρ. 202 παρ. 2).

Εγκρίθηκε από τα Μέλη της Επταμελούς Εξεταστικής Επιτροπής:

Πρώτος Εξεταστής (Επιβλέπων Καθηγητής)

Δρ. Γεώργιος Λυμπερόπουλος, Καθηγητής Τμήματος Μηχανολόγων Μηχανικών
Πανεπιστημίου Θεσσαλίας

Δεύτερος Εξεταστής (μέλος Συμβουλευτικής Επιτροπής)

Δρ. Αθανάσιος Ζηλιασκόπουλος, Καθηγητής Τμήματος Μηχανολόγων Μηχανικών
Πανεπιστημίου Θεσσαλίας

Τρίτος Εξεταστής (μέλος Συμβουλευτικής Επιτροπής)

Δρ. Γεώργιος Ταγαράς, Καθηγητής Τμήματος Μηχανολόγων Μηχανικών Αριστοτελείου
Πανεπιστημίου Θεσσαλονίκης

Τέταρτος Εξεταστής

Δρ. Δημήτριος Παντελής, Επίκουρος Καθηγητής Τμήματος Μηχανολόγων Μηχανικών
Πανεπιστημίου Θεσσαλίας

Πέμπτος Εξεταστής

Δρ. Γεώργιος Κοζανίδης, Λέκτορας Τμήματος Μηχανολόγων Μηχανικών Πανεπιστημίου
Θεσσαλίας

Έκτος Εξεταστής

Δρ. Μιχαήλ Γεωργιάδης, Αναπληρωτής Καθηγητής Τμήματος Μηχανικών Πληροφορικής και
Τηλεπικοινωνιών Πανεπιστημίου Δυτικής Μακεδονίας

Έβδομος Εξεταστής

Δρ. Αιμιλία Κονδύλη, Αναπληρώτρια Καθηγήτρια Τμήματος Μηχανολογίας Τεχνολογικού
Εκπαιδευτικού Ιδρύματος Πειραιά

Ευχαριστίες

Καταρχάς, θέλω να ευχαριστήσω τον επιβλέποντα της διδακτορικής διατριβής μου, Καθηγητή κ. Γεώργιο Λυμπερόπουλο, για την πολύτιμη καθοδήγηση και επίβλεψη της διατριβής μου. Επίσης, ευχαριστώ τα υπόλοιπα μέλη της εξεταστικής επιτροπής της διατριβής μου, Καθηγητές κκ. Αθανάσιο Ζηλιασκόπουλο, Γεώργιο Ταγαρά, Δημήτριο Παντελή, Γεώργιο Κοζανίδη, Μιχαήλ Γεωργιάδη και Αιμιλία Κονδύλη, για την προσεκτική ανάγνωση της εργασίας μου και για τις χρήσιμες υποδείξεις τους. Ιδιαίτερες ευχαριστίες οφείλω στους Καθηγητές κ. Κοζανίδη και κ. Παντελή για την σημαντική καθοδήγησή τους στις δύο βασικές ενότητες της διατριβής μου που παρουσιάζονται στα Κεφάλαια 2 και 3, αντίστοιχα. Ακόμα, ευχαριστώ θερμά όλους τους φίλους και συνεργάτες μου και ιδιαίτερα τον Ευστράτιο Αθανασίου που με βοήθησαν και με υποστήριξαν κατά την διάρκεια της εκπόνησης της διατριβής μου. Πάνω από όλα, είμαι ευγνώμων στους γονείς μου, Δημήτρη και Αριστέα Χατζηκωνσταντίνου και στην αδερφή μου Μαρία, για την ολόψυχη υποστήριξή τους όλα τα χρόνια των σπουδών μου. Τους αφιερώνω τη διδακτορική διατριβή μου.

Η εκπόνηση της παρούσας διατριβής υποστηρίχθηκε οικονομικά από το έργο «03ΕΔ913 – Βελτιστοποίηση προγραμματισμού παραγωγής και διανομής προϊόντων σε χημική βιομηχανία παραγωγής ρητίνης PET» που συγχρηματοδοτήθηκε από πόρους του δημόσιου (85%) και ιδιωτικού τομέα (15%) στο πλαίσιο της Πράξης ΠΕΝΕΔ 2003 του Μέτρου 8.3 του Επιχειρησιακού Προγράμματος «Ανταγωνιστικότητα» του Γ' Κοινοτικού Πλαισίου Στήριξης. Το 75% της δημόσιας δαπάνης προήλθε από την Ευρωπαϊκή Ένωση (Ευρωπαϊκό Κοινοτικό Ταμείο) και το 25% από το Ελληνικό Δημόσιο (Υπουργείο Ανάπτυξης: Γενική Γραμματεία Έρευνας και Τεχνολογίας). Η ιδιωτική δαπάνη προήλθε εξ' ολοκλήρου από την βιομηχανία Artenius Hellas, S.A., PET Industry, μέλους του ομίλου βιομηχανιών συσκευασιών PET, La Seda de Barcelona. Θέλω να ευχαριστήσω τον Διευθυντή του εργοστασίου της Artenius Hellas, κ. Δημήτριο Φιλίππου, και τους συνεργάτες του, για την πολύτιμη καθοδήγησή τους, ιδιαίτερα στα αρχικά στάδια της διατριβής, που με μύησε στις λεπτομέρειες ενός πραγματικού προβλήματος της βιομηχανίας το οποίο απετέλεσε κίνητρο για την ανάπτυξη των προτύπων και μεθοδολογιών που παρουσιάζονται στην διατριβή.

Ολυμπία Χατζηκωνσταντίνου

ΒΕΛΤΙΣΤΟΠΟΙΗΣΗ ΠΡΟΓΡΑΜΜΑΤΙΣΜΟΥ ΠΑΡΑΓΩΓΗΣ ΚΑΙ ΔΙΑΝΟΜΗΣ ΠΡΟΪΟΝΤΩΝ ΣΕ ΧΗΜΙΚΗ ΒΙΟΜΗΧΑΝΙΑ ΡΗΤΙΝΗΣ PET

ΟΛΥΜΠΙΑ ΧΑΤΖΗΚΩΣΤΑΝΤΙΝΟΥ

Πανεπιστήμιο Θεσσαλίας, Πολυτεχνική Σχολή, Τμήμα Μηχανολόγων Μηχανικών, 2009

Επιβλέπων Καθηγητής: Δρ. Γεώργιος Λυμπερόπουλος, Καθηγητής Στοχαστικών Μεθόδων στη
Διοίκηση Παραγωγής

Περίληψη

Το κίνητρο της διδακτορικής διατριβής προήλθε από την ανάγκη βελτιστοποίησης του προγραμματισμού παραγωγής σε μια πραγματική χημική βιομηχανία παραγωγής ρητίνης PET. Η ανάγκη αυτή οδήγησε στην ανάπτυξη δύο διαφορετικών μαθηματικών μοντέλων που αντιμετωπίζουν το πρόβλημα του προγραμματισμού παραγωγής στη συγκεκριμένη βιομηχανία αλλά και σε άλλες με παρεμφερή χαρακτηριστικά, σε δύο διαφορετικά επίπεδα. Ο βασικός κορμός της διδακτορικής διατριβής αποτελείται από δύο βασικές ενότητες, στις οποίες παρουσιάζεται η μορφοποίηση, ανάλυση και επίλυση των δύο αυτών μοντέλων, αντίστοιχα.

Στην πρώτη ενότητα που καταλαμβάνει το Κεφάλαιο 2, αναπτύσσεται ένα μοντέλο Μεικτού Ακέραιου Γραμμικού Προγραμματισμού (Mixed Integer Linear Programming ή MILP) για τον χρονικό προγραμματισμό της παραγωγής μιας μονάδας συνεχούς ροής που παράγει διαφορετικές ποιότητες (*grades*) ρητίνης PET. Ο χρόνος στο μοντέλο είναι διακριτοποιημένος. Ο αντικειμενικός

στόχος είναι να ελαχιστοποιηθεί το κόστος που σχετίζεται με τις αλλαγές ρύθμισης (setup changeovers) της παραγωγής από μία ποιότητα προϊόντος σε μια άλλη, ούτως ώστε να αποφευχθούν ανεπιθύμητες μεταβολές στις ιδιότητες του παραγόμενου προϊόντος που λαμβάνουν χώρα κατά την διάρκεια τέτοιων αλλαγών. Οι περιορισμοί του μοντέλου αφορούν, μεταξύ άλλων, την σειρά των αλλαγών ρύθμισης παραγωγής, την σειριακή παραγωγή με περιορισμένη παραγωγική δυναμικότητα και περιορισμένη χωρητικότητα, την μικτή και ευέλικτη πεπερασμένη χωρητικότητα αποθηκών ενδιάμεσων και τελικών προϊόντων, τις απαιτήσεις ικανοποίησης της ζήτησης σε ενδιάμεσες ημερομηνίες (και όχι μόνον στο τέλος του ορίζοντα προγραμματισμού), κ.α. Παρουσιάζεται μια μελέτη περίπτωσης που καταδεικνύει πώς μπορεί να εφαρμοστεί το μοντέλο σε ένα πραγματικό σενάριο και οδηγεί στην εξαγωγή χρήσιμων συμπερασμάτων και ενόρασης όσον αφορά στην συμπεριφορά του μοντέλου. Η εμπειρία από τα αριθμητικά παραδείγματα δείχνει ότι οι υπολογιστικές απαιτήσεις για την επίλυση του μοντέλου είναι λογικές για μεγέθη προβλημάτων που απαντώνται σε πρακτικές εφαρμογές.

Το μοντέλο βελτιστοποίησης του προγραμματισμού της παραγωγής που παρουσιάζεται στην πρώτη ενότητα της διατριβής είναι ένα κλασικό καθοριστικό μοντέλο διακριτού χρόνου και πεπερασμένου χρονικού ορίζοντα. Περιγράφει με μεγάλη ακρίβεια το πραγματικό πρόβλημα προγραμματισμού παραγωγής σε έναν βραχύ χρονικό ορίζοντα (τυπικά, μια εβδομάδα), όπου η ζήτηση των διαφορετικών ποιοτήτων θεωρείται γνωστή. Όμως, επειδή στο πραγματικό σύστημα, η παραγωγή και η ζήτηση συνεχίζονται και μετά το πέρας του ορίζοντα προγραμματισμού, το πρόγραμμα παραγωγής είναι λογικό να μην επιτρέπει στο απόθεμα των προϊόντων να πέσει κάτω από κάποιο απόθεμα ασφαλείας, ούτως ώστε να μπορεί να αντιμετωπισθεί η αβέβαιη ζήτηση και μετά το πέρας του χρονικού ορίζοντα προγραμματισμού. Για τον αποτελεσματικό σχεδιασμό των αποθεμάτων ασφαλείας απαιτείται μια πιο μακροσκοπική ανάλυση που να περιγράφει το σύστημα

με λιγότερη λεπτομέρεια, αλλά να λαμβάνει ρητά υπόψη την στοχαστική φύση της ζήτησης. Μια τέτοια ανάλυση αποτελεί το αντικείμενο της δεύτερης ενότητας της διδακτορικής διατριβής.

Συγκεκριμένα, στη δεύτερη ενότητα που καταλαμβάνει το Κεφάλαιο 3, αναπτύσσεται ένα μαθηματικό μοντέλο μιας παραλλαγής του Στοχαστικού Προβλήματος του Βέλτιστου Χρονικού Προγραμματισμού Παρτίδων Παραγωγής (Stochastic Economic Lot Scheduling Problem ή SELSP), στο οποίο μια μονάδα συνεχούς παραγωγής πρέπει να παράγει διαφορετικές ποιότητες μιας οικογένειας προϊόντων για να ικανοποιήσει τυχαία αλλά στάσιμα κατανεμημένη ζήτηση για κάθε ποιότητα από μια κοινή αποθήκη τελικών προϊόντων με περιορισμένη χωρητικότητα. Η ζήτηση που δεν μπορεί να ικανοποιηθεί από το απόθεμα, χάνεται. Η πρώτη ύλη είναι πάντα διαθέσιμη, και η μονάδα παραγωγής παράγει συνεχώς και με σταθερό ρυθμό. Όταν η μονάδα είναι ρυθμισμένη να παράγει μια συγκεκριμένη ποιότητα, οι μόνες επιτρεπτές αλλαγές είναι από αυτή την ποιότητα στην αμέσως χαμηλότερη ή υψηλότερη ποιότητα. Όλοι οι χρόνοι αλλαγών είναι σταθεροί και ίδιοι. Υπάρχει ένα κόστος αλλαγής ανά περίπτωση αλλαγής, ένα κόστος υπερχείλισης ανά μονάδα πλεονασματικού προϊόντος οποτεδήποτε δεν υπάρχει αρκετός χώρος στην αποθήκη τελικών προϊόντων για να αποθηκευτεί το παραγόμενο προϊόν, και ένα κόστος χαμένων πωλήσεων ανά μονάδα ελλειμματικού προϊόντος οποτεδήποτε δεν υπάρχει αρκετό απόθεμα τελικών προϊόντων για να ικανοποιηθεί η ζήτηση. Μοντελοποιούμε το SELSP ως μια Μαρκοβιανή Διαδικασία Αποφάσεων (Markov Decision Process ή MDP) διακριτού χρόνου, όπου σε κάθε περίοδο η απόφαση είναι αν θα ξεκινήσει μια αλλαγή ρύθμισης προς μια γειτονική ποιότητα προϊόντος ή αν θα παραμείνει η ρύθμιση της μονάδας παραγωγής ως έχει, βάσει της τρέχουσας κατάστασης του συστήματος που ορίζεται από την τρέχουσα ρύθμιση της μονάδας και τα επίπεδα αποθεμάτων τελικών προϊόντων όλων των ποιοτήτων. Ο στόχος είναι να ελαχιστοποιηθεί το μακροχρόνιο (απείρου ορίζοντα) προσδοκώμενο μέσο κόστος ανά περίοδο. Για προβλήματα 2 και 3 ποιοτήτων προϊόντος επιλύουμε αριθμητικά το ακριβές πρόβλημα MDP χρησιμοποιώντας την μέθοδο των διαδοχικών προσεγγίσεων του διαφορικού κόστους. Για προβλήματα με περισσότερες από 3 ποιότητες προϊόντος αναπτύσσουμε μια ευρετική διαδικασία επίλυσης

που βασίζεται στην προσέγγιση του αρχικού προβλήματος των πολλαπλών ποιοτήτων από πολλά υποπροβλήματα 3 ποιοτήτων που επιλύονται με την μέθοδο των διαδοχικών προσεγγίσεων. Παρουσιάζουμε αριθμητικά αποτελέσματα για παραδείγματα προβλημάτων 2-5 ποιοτήτων. Για τα παραδείγματα των 2 και 3 ποιοτήτων χρησιμοποιούμε την ακριβή μέθοδο επίλυσης για να αποκτήσουμε ενόραση όσον αφορά στη δομή της βέλτιστης πολιτικής αλλαγών ρύθμισης. Για τα παραδείγματα των 4 και 5 ποιοτήτων συγκρίνουμε την απόδοση της ευρετικής διαδικασίας επίλυσης σε σχέση με αυτήν της ακριβούς μεθόδου.

UNIVERSITY OF THESSALY
SCHOOL OF ENGINEERING
DEPARTMENT OF MECHANICAL ENGINEERING

Dissertation

**PRODUCTION SCHEDULING OPTIMIZATION IN A PET RESIN
CHEMICAL INDUSTRY**

by

OLYMPIA HATZIKONSTANTINO

Diploma in Mechanical & Aeronautical Engineering, University of Patras, 2005
Postgraduate Specialization Diploma in Mechanical Engineering, University of Thessaly, 2009

Submitted in partial fulfillment of the
requirements for the degree of
Doctor of Philosophy

2009

© 2009 Olympia Hatzikonstantinou

The approval of this Ph.D. Dissertation by the Department of Mechanical Engineering of the School of Engineering of the University of Thessaly does not imply acceptance of the writer's opinions.
(Law 5343/32, article 202 par. 2).

Approved by the Members of the Examination Committee:

First Reader (Advisor)

Dr. **George Liberopoulos**, Professor, Department of Mechanical Engineering, University of Thessaly

Second Reader (member of Advisory Committee)

Dr. **Athanasios Ziliaskopoulos**, Professor, Department of Mechanical Engineering, University of Thessaly

Third Reader (member of Advisory Committee)

Dr. **George Tagaras**, Professor, Department of Mechanical Engineering, Aristotle University of Thessaloniki

Fourth Reader

Dr. **Dimitrios Pandelis**, Assistant Professor, Department of Mechanical Engineering, University of Thessaly

Fifth Reader

Dr. **George Kozanidis**, Lecturer, Department of Mechanical Engineering, University of Thessaly

Sixth Reader

Dr. **Michael Georgiadis**, Associate Professor, Department of Computer and Telecommunications Engineering, University of Western Macedonia

Seventh Reader

Dr. **Emilia Kondili**, Associate Professor, Department of Mechanical Technology, Technical Educational Institute of Piraeus

Acknowledgements

First and foremost, I want to thank my dissertation advisor, Professor George Liberopoulos, for his valuable guidance and supervision of my dissertation. I also thank the other members of the examination committee of my dissertation, Professors Athanasios Ziliaskopoulos, George Tagaras, Dimitrios Pandelis, George Kozanidis, Michael Georgiadis and Emilia Kodili, for carefully reading my dissertation and making useful suggestions. I owe special thanks to Professors Kozanidis and Pandelis for guiding me through the two main parts of my dissertation, which are presented in Chapters 2 and 3, respectively. In addition, I thank all my friends and colleagues, especially Efstathios Athanasiou, who helped and supported me during my PhD work. Above all, I am indebted to my parents, Dimitris and Aristeia Hatzikonstantinou and my sister Maria, for their unconditional support throughout all the years of my studies. I dedicate this dissertation to them.

The work presented in this dissertation was supported by grant “03Δ913 – Optimization of production scheduling and product distribution in a chemical plant producing PET resin,” which was co-financed by the public (85%) and private (15%) sector within the Action “PENED 2003” of Measure 8.3 of the Operational Program “Competitiveness” of the third European Community Support Framework. 75% of the public funding came from the European Union (European Community Fund) and 25% came from the Greek Public Sector (Ministry of Development – General Secretariat of Research and Technology). All private funding came from Artenius Hellas, S.A., PET Industry, which is a member of the group La Seda de Barcelona, that specializes in PET industrial packaging. I want to thank the plant manager, Mr. Dimitris Filippou, and his colleagues for their valuable guidance, especially at the early stages of my dissertation, which introduced me into the details of a real industrial problem that motivated the development of the models and solution methodologies presented in my dissertation.

Olympia Hatzikonstantinou

PRODUCTION SCHEDULING OPTIMIZATION IN A PET RESIN CHEMICAL INDUSTRY

OLYMPIA HATZIKONSTANTINOY

University of Thessaly, School of Engineering, Department of Mechanical Engineering, 2009

Dissertation Supervisor: Dr. George Liberopoulos, Professor of Production Management

Abstract

The motivation for this dissertation originated from the need to optimize the scheduling of production in a real PET resin plant. This need led to the development of two different mathematical models that address the production scheduling problem in the particular industry that motivated this study as well as in similar industries at two different levels. The main body of the dissertation is divided into two parts in which we present the formulation, analysis and solution of each of the two models, respectively.

In the first part, which occupies Chapter 2, we develop a discrete-time, Mixed Integer Linear Programming (MILP) model for the production scheduling of a continuous-process multi-grade PET resin plant. The objective is to minimize the cost associated with grade changeovers in order to avoid undesirable variations in base resin properties and process conditions that occur during such changes. The constraints of the model include requirements related to sequence-dependent changeovers, sequential processing with production and space capacity, mixed and flexible finite intermediate storage, and intermediate demand due-dates. We present a case study that illustrates the application of the model on a real problem scenario and provides insight into its behavior. The

numerical experience demonstrates that the computational requirements of the model are quite reasonable for problem sizes that typically arise in practical applications.

The production scheduling optimization model that is presented in the first part of this dissertation, is a typical deterministic, discrete-time, finite-horizon optimization model. It describes in great detail and accuracy the real production scheduling problem in the short term (typically one week), where the demand for the different grades is considered to be known. In real life, however, production and demand continue after the end of the scheduling horizon. With this in mind, it is reasonable to design the production schedule in such a way that the finished goods inventory at the end of the scheduling horizon does not fall below a certain safety stock level, so that the unknown random demand after the end of the scheduling horizon can be met. To effectively design such safety stock levels for each grade, it is necessary to perform a more macroscopic analysis which describes the system in less detail but takes into account the stochastic nature of demand. Such an analysis is performed in the second part of this dissertation.

More specifically, in the second part, which occupies Chapter 3, we study a variant of the Stochastic Economic Lot Scheduling Problem (SELSP) in which a single production facility must produce several different grades of a family of products to meet random stationary demand for each grade from a common Finished-Goods (FG) inventory buffer with limited storage capacity. Demand that can not be satisfied directly from inventory is lost. Raw material is always available, and the production facility continuously produces at a constant rate. When the facility is set up to produce a particular grade, the only allowable changeovers are from that grade to the next lower or higher grade. All changeover times are constant and equal to each other. There is a changeover cost per changeover occasion, a spill-over cost per unit of product in excess whenever there is not enough space in the FG buffer to store the produced grade, and a lost-sales cost per unit short whenever there is not enough FG inventory to satisfy the demand. We model the SELSP as a

discrete-time Markov Decision Process (MDP), where in each time period the decision is whether to initiate a changeover to a neighboring grade or keep the set up of the production facility unchanged, based on the current state of the system which is defined by the current set up of the facility and the FG inventory levels of all the grades. The goal is to minimize the (long-run) expected average cost per period. For 2- and 3-grade problems, we numerically solve the exact MDP problem using the value iteration method. For problems with more than three grades, we develop a heuristic solution procedure which is based on approximating the original multi-grade problem by several 3-grade sub-problems and numerically solving each sub-problem using value iteration. We present numerical results for problem examples with 2-5 grades. For the 2- and 3-grade examples, we use the exact solution procedure to obtain insights into the structure of the optimal changeover policy. For the 4- and 5-grade examples, we compare the performance of the heuristic solution procedure against that of the exact procedure.

Contents

Chapter 1	Introduction.....	1
1.1	Motivation and background	1
1.2	Literature review	3
1.3	Dissertation organization	12
Chapter 2	Production scheduling of a multi-grade PET resin plant	15
2.1	Operation of a PET plant	16
2.2	MILP model development	23
2.3	Application of the model.....	37
2.3.1	Computation of safety stock levels	39
2.3.2	Numerical results	43
2.3.3	Computational experience	49
2.4	Conclusions	55
Chapter 3	The stochastic economic lot sizing problem for continuous nonstop multi-grade production	57
3.1	Introduction	58
3.2	Problem formulation and dynamic programming solution.....	62
3.3	Heuristic solution procedure	65
3.4	Numerical results.....	69
3.4.1	2-grade example	70
3.4.2	3-grade example	77
3.4.3	4-grade and 5-grade examples	82
3.5	Conclusions	86
Chapter 4	Dissertation summary	89
	Bibliography	93
	Appendix A: Demand data used in the MILP model application presented in Section 2.3	101
	Appendix B: Single 2-week MILP problem results vs. two 1-week MILP problem results for the MILP model application presented in Section 2.3.....	105
	Appendix C: AMPL codes for the MILP problem developed in Section 2.2.....	109
	Appendix D: Matlab codes for implementing the exact and heuristic solution procedures developed in Sections 3.2 and 3.3.....	117
	Appendix E: Results of the heuristic policy evaluated in Section 3.4.3 for different values of parameter α	135

List of Tables

Table 2-1. Grade of final product based on color and IV combination	17
Table 2-2. Sample mean and standard deviation of the daily demand for each grade and demand type.....	39
Table 2-3. Optimal safety stock level of grade j , when the facility is set up to produce grade i , $I_{\min,i,j}$	41
Table 2-4. Mean daily demand, $E[d_j]$, market share, p_j , and safety stock level, $I_{\min,j}$, for each grade j	41
Table 2-5. Fraction of the demand requested from the LFSS silos and the warehouse, and safety stock level in the LFSS silos and the warehouse, for each grade j	42
Table 2-6. Safety stocks at the LFSS and the warehouse, and initial quantities in the warehouse....	43
Table 2-7. Number of binary decision variables.....	50
Table 2-8. Number of continuous decision variables	50
Table 2-9. Number of constraints	51
Table 2-10. Optimal cost (number of changeovers) and CPU time for each of the 24 runs of the numerical example presented in Section 2.3.....	52
Table 2-11. Effect of increasing the length of the scheduling horizon	53
Table 3-1. Probability distribution of demand, $\Pr(D_n=i)$, for the 2-grade example	70
Table 3-2. Results for the 2-grade example	71
Table 3-3. Optimal policy $\mu^*(s, R)$ for the 2-grade example.....	73
Table 3-4. Description of bottle-grade PET resin final products.....	77
Table 3-5. Probability distribution of demand, $\Pr(D_n=i)$, for the 3-grade example.....	78
Table 3-6. Optimal policy $\mu^*(s, R)$ for the 3-grade example.....	79
Table 3-7. Optimal target inventory level, $x_n^*(s)$, for the 3-grade example	81
Table 3-8. Probability distribution of demand, $\Pr(D_j = i)$, for the 4-grade and 5-grade examples	82
Table 3-9. Results for the 4-grade example	84
Table 3-10. Results for the 5-grade example	86
Table A-1. Daily demand values for 6 months used in the example solved in Section 2.3.....	101
Table A-2. Optimal cost (number of changeovers) and CPU time for each of the 100 instances of the numerical example presented in Section 2.3, where we solved the scheduling problem for weeks 5 and 6 as a single 2-week MILP problem and as two sequential 1-week MILP problems, respectively	105

Table A-3. Complete set of results of the heuristic policy evaluated using the value iteration method for the 4-grade example presented in Section 3.4.3.....	135
Table A-4. Complete set of results of the heuristic policy evaluated using simulation for the 4-grade example presented in Section 3.4.3.....	136
Table A-5. Complete set of results of the heuristic policy evaluated using simulation for the 5-grade example presented in Section 3.4.3.....	137

List of Figures

Figure 2-1. Material flow in a PET resin production plant.....	19
Figure 2-2. Time shift representation in the production process	30
Figure 2-3. Evolution of the final grade produced in each period	43
Figure 2-4. Evolution of inventory level in silos 1-4 of the LFSS at the end of each week.....	44
Figure 2-5. Evolution of inventory level in silos 5-8 of the LFSS at the end of each week.....	45
Figure 2-6. Evolution of inventory level in the warehouse at the end of each week.....	45
Figure 2-7. Evolution of inventory level in silos 1-4 of the LFSS at the end of each period in week 5	46
Figure 2-8. Evolution of inventory level in silos 5-8 of the LFSS at the end of each period in week 5	47
Figure 2-9. Evolution of inventory level in the warehouse at the end of each period in week 5.....	47
Figure 2-10. Scheduled demand per grade and type for each period in week 5	48
Figure 2-11. Color setting at POLY, IV setting at SSP and final grade produced in each period of week 5	49
Figure 3-1. Optimal changeover policy for cases 2 (left) and 4 (right) of Table 3-2, for $X = 40$	74
Figure 3-2. Optimal changeover policy for case 3 (left) and case 1 (right) of Table 3-2, for $X = 80$	76
Figure 3-3. Optimal changeover policy for $x_2 = 90$ (left) and $x_2 = 70$ (right), for the 3-grade example	80
Figure 3-4. Optimal changeover policy for $x_2 = 30$ (left) and $x_2 = 10$ (right), for the 3-grade example	80
Figure 3-5. Expected average cost per period of the heuristic, $J^h(\alpha)$, vs. α , for the 4-grade example	85
Figure 3-6. Expected average cost per period of the heuristic, $J^h(\alpha)$, vs. α , for the 5-grade example	86

Chapter 1 Introduction

In this chapter, we provide some background information which supports the motivation behind this dissertation. We also review the relevant literature, and we give a brief description of the two main parts of the dissertation, which occupy Chapters 2 and 3, respectively.

1.1 Motivation and background

Chemicals and plastics production is based on the processing of oil, natural gas and coal. It starts from a few main organic monomer chemical groupings, such as ethylene and propylene, from which various polymers are produced. A handful of these polymers form the inputs into manufactured intermediate and final plastic products. Although polymerization occurs via a variety of reaction mechanisms with different degrees of complexity, the industrial production of most polymers is more or less the same, from an operations management point of view. More specifically, it is common for polymerization plants to operate in a continuous manner in which several grades are produced using the same equipment. In this context, grades are understood as products made from the same polymer but with different end use properties, such as brightness, color, mechanical strength, etc. These end use properties of grades are dependent on molecular weight distribution and monomer conversion, which in turn are determined by operating conditions. Transition times in grade polymerization plants can be long, resulting in a considerable amount of off-specifications production. As such, the number of transitions to be made during a production

sequence is an important aspect to consider when determining a production schedule for polymerization plants (Terrazas-Moreno et al. 2007).

One of the most important classes of polymers in use today is polyesters, which contain the ester functional group in their main chain. The widespread uses of polyesters range from bottles for carbonated soft drinks and water to fibers for shirts and other apparel. Polyesters also form the basis for photographic film and recording tape. Although there are many polyesters, the term “polyester” as a specific material most commonly refers to Polyethylene Terephthalate (PET), which is the workhorse polyester used for packaging, stretch-blown bottles and for the production of fiber of textile products. In this thisis, we focus on the production scheduling of bottle-grade PET. The scheduling paradigm that we develop for PET, however, is representative of the entire polymer production industry, because it has similar characteristics from an operations management point of view, as was mentioned above.

PET is an inert plastic that does not leach harmful materials into its contents, when used as a container. For this reason, it has been the main solution for the production of packaging containers for over 20 years. The US Food and Drug Administration (FDA) has done rigorous testing to ensure that PET containers are safe and suitable for food and beverage storage and use. As a result, PET has been widely used for the production of food and beverage containers. An additional advantage of PET containers is that they are 100% recyclable and extremely light. Thus, they help diminish the formation of packaging waste and reduce the emission of contaminants during their transport. Furthermore, since they require less fuel during transportation, they also help saving energy.

According to McGehee et al. (2004), the key factors that increase the cost of production in a PET plant are: 1) insufficient equipment utilization, 2) unscheduled down-time and upsets, 3) variations in grade quality/waste and 4) transitions during grade changes. The first three factors can be dealt with by using good engineering and operational practices and by adopting process changes

and revamps, such as implementing effective hardware modifications, carefully scheduling preventive maintenance, instituting rational quality management programs, and minimizing the effect of systematic sources of variability to the plant. The fourth factor can be dealt with by implementing careful and intelligent production scheduling. McGehee et al. (2004), expect that the practice of managing solid state polymerization plants by predictive scheduling will become more crucial in the upcoming years, since this is the most effective way to quickly respond to customer requirements with grade campaigns without large storage volumes or waste.

In Chapter 2 of this dissertation, we present a discrete-time Mixed Integer Linear Programming (MILP) model for the detailed production scheduling of a continuous-process plant that produces several grades of PET resin that is to be used for making beverage bottles. An important set of parameters of the MILP model is the set of safety stock levels of the finished goods inventories of the different grades at the end of the scheduling horizon. To design these parameters, in Chapter 3, we develop and analyze a more macroscopic model of the plant, where we view the plant as a single production facility that must produce several different grades of a family of products to meet random stationary demand for each grade from a common finished goods inventory buffer with limited storage capacity. This gives rise to a variant of the Stochastic Economic Lot Sizing Problem (SELSP) which we model as a discrete-time Markov Decision Process (MDP), and solve using exact and heuristic solution procedures.

1.2 Literature review

The literature on chemical process scheduling is vast and rapidly growing, as indicated by the existence of numerous published reviews that bring to light a wealth of general-purpose modeling approaches and solution techniques. A common theme in many of these reviews (e.g., Kallrath, 2002 and Méndez et al., 2006) is the classification of process scheduling models and solution

approaches in terms of plant topology, process representation, time representation, operation modes, demand pattern, changeover and storage characteristics, and other features that are involved in most process scheduling problems.

An important differentiation is made between batch processes and continuous processes, with most of the published works addressing batch processes. Reklaitis (1992) overviews the scheduling and planning of batch process operations, focusing on the basic elements of chemical process scheduling problems and the available solution methods, while Kondili et al. (1993) present a general framework for handling a wide range of scheduling problems arising in batch chemical plants. There are numerous other more recent works on batch process scheduling. Typical examples are the work of Grünow et al. (2002), who present a hierarchical modeling approach to coordinate various plant operations in a multi-stage batch process chemical industry, and the works of Janak et al. (2006a, 2006b), who present efficient MILP formulations for scheduling large-scale industrial batch plants. In the context of continuous processes, a very recent work by Shaik et al. (2009) presents a framework for short-term and medium-term scheduling of large-scale industrial continuous plants.

Another important differentiation in the process scheduling literature is between discrete-time and continuous-time models. Ierapetritou and Floudas (1998a,1998b) propose effective continuous-time formulations for both batch and continuous processes. Janak et al. (2004) extend these formulations to incorporate several additional features, such as different storage policies, resource constraints, variable batch sizes and processing times, batch mixing and splitting, and sequence-dependent changeover times, while Shaik and Floudas (2007) further extend them to rigorously treat storage requirements. Lin and Floudas (2001) propose a continuous-time formulation for design, synthesis and scheduling of multipurpose batch plants, and test it on both

linear and nonlinear cases, and Shaik et al. (2006) present a performance comparison and evaluation of several continuous-time models for short-term scheduling of multipurpose batch plants.

Mockus and Reklaitis (1999) address the problem of decision timing in the context of batch and continuous process scheduling, Neumann et al. (2002) develop a batch scheduling problem that is modeled as a resource-constrained problem and is solved by an efficient truncated branch-and-bound algorithm, and Giannelos and Georgiadis (2002) propose a formulation for short-term scheduling of multipurpose continuous processes. A relatively recent overview and comparison of discrete-time and continuous-time approaches for the scheduling of chemical processes can be found in Floudas and Lin (2004). The focus there is on a class of processes called sequential, which exhibit a linear structure in the production recipe, without material merging/splitting or recycle. The model that we study in this dissertation falls into that class. Finally, in a recent monograph, Suerie (2005) addresses the issue of time-continuity in discrete time models.

Chemical process scheduling models can be efficiently formulated using mixed integer optimization techniques. Grossmann et al. (1996) provide an overview of such techniques for the design and scheduling of batch processes, emphasizing on general-purpose methods for MILP and Mixed Integer Non Linear Programming (MINLP) problems. Pinto and Grossmann (1998) present an overview of assignment and sequencing models used in the scheduling of process operations with mathematical programming techniques. The authors identify two major categories of scheduling models, single-unit and multiple-unit assignment models, and discuss the critical modeling issues of time domain representation and network structure. Méndez and Cerdá (2002) propose a MILP mathematical formulation for scheduling resource-constrained multigrade continuous chemical plants that uses a continuous-time domain representation. Janak and Floudas (2008) suggest preprocessing techniques for closing the integrality gap of MILP continuous-time formulations for batch processing scheduling. Other MILP models for production scheduling of

chemical processes have been proposed by Pinto and Grossmann (1995), Lee et al. (1996), Pinto (1997), Hui et al., (2000) and Castro and Grossmann (2006), to name a few. A recent review of several MILP based approaches for the scheduling of chemical process facilities which focuses on short-term scheduling of processes that can be represented as general networks can be found in Floudas and Lin (2005).

Besides the general-purpose modeling approaches for the scheduling of generic chemical process industries, there have also been several works that are specific to the scheduling of different types of polymerization processes. One such example is the work by Qiu and Burch (1997), who develop a hierarchical production planning and scheduling model to solve a real-world problem in fiber manufacturing scheduling. The model requires determining production sequences in the presence of variable setup costs in a multi-machine and multi-grade environment. The emphasis is on the integration of the different levels of the hierarchy and on the development of the concept of the expected setup cost to circumvent the difficulty that until the production sequences are known, the exact setup costs can not be determined. Another example is the work of Wang et al. (2000), who develop a MINLP model for the batch scheduling of a polymer plant producing expandable polystyrene. None of the different products can be produced separately and only their relative proportion can be influenced by the choice of the recipes of the polymerizations. An augmented genetic algorithm is used to solve the model.

Recently, there have also been some works on the joint optimization of scheduling and process control during changeover transitions in polymerization processes. Mahadevan et al. (2002) analyze the schedule of grade transitions for a polymerization reactor (isothermal free radical polymerization of methyl methacrylate (MMA) with azobis-isobutyronitrile as initiator and toluene as the solvent) that is controlled by a simple linear controller. The dominant factor determining the schedule of grade transitions is the transition cost related to the off-specification product. Nyström

at al. (2005) present a method for solving the problem of grade transition sequencing and dynamic optimization in polymerization processes. The method is based on decomposing the problem into two separate sub-problems – dynamic optimization (called primal problem) and scheduling (called master problem) – and solving them in an iterative manner. Terrazas-Moreno et al. (2007) present a Mixed Integer Dynamic Optimization (MIDO) model for the simultaneous optimal scheduling and control during transitions of a multi-grade polymerization continuous stirred-tank reactor. The schedules sought are strictly cyclic (each grade is produced once in each cycle), and the storage requirements downstream of the reactor are treated simplistically. The emphasis is on the behavior of the process during transitions. In a somewhat related work, Prata et al. (2008) present a MIDO modeling and numerical solution method for an integrated grade transition and production scheduling problem for a continuous polymerization reactor typically used for the production of homo- and copolymers of olefins. The emphasis is on modeling the nonlinear dynamics of the polymerization process in the reactor during transitions, but the downstream process units following the reactor are neglected. All the above works focus on different aspects of polymerization process scheduling (e.g., on the integration of planning and scheduling, on the use of genetic algorithms to solve the scheduling problem, on the combination of optimal scheduling and process control during transitions), but none is directly related to our work, as none includes in detail aspects such as inventory management and market demand for different grades.

Finally, there are many production scheduling models for continuous chemical processes that are similar to the one that we address in this work. For example, Bok and Park (1998) present an efficient short-term scheduling mixed integer programming model for a multipurpose pipeless plant over a continuous-time domain. Doganis et al. (2005) develop a MILP model for determining the optimal production schedule in a lubricant production plant, and Tousain and Bosgra (2006)

propose an approach for flexible production scheduling in continuous multi-grade chemical processes.

To the best of our knowledge, the development of an optimization model for production scheduling in a PET production facility has not been addressed in the past. Moreover, as was mentioned earlier, the PET plant that we consider in this dissertation has several features that make it unbecoming the general-purpose models discussed above. For this reason, in Chapter 2, we develop a specific MILP model for it that is general enough, however, to be applicable to other similar applications, particularly in the polymer production industry.

In Chapter 3, we view the production scheduling problem as a variant of the SELSP. The SELSP has received considerable attention in the literature because of its theoretical and practical importance. A comprehensive review of related works can be found in Sox et al. (1999) and Winands et al. (2005). From these reviews, it is apparent that there have been two approaches for tackling the SELSP. One approach is to develop a cyclic schedule, i.e., a fixed production sequence, usually using a deterministic approximation of the stochastic problem, and then develop a control rule for the stochastic problem to pursue that schedule. The literature on this approach is relatively rich, as it has grown naturally from the abundant deterministic ELSP literature. Representative works based on cyclic scheduling are Gallego (1990, 1994), Bourland and Yano (1994), Fransoo et al. (1995), Federgruen and Katalan (1996), Leachman and Gascon (1998), Anupindi and Tayur (1998), Markowitz et al. (2000) and Markowitz and Wein (2001). The attractiveness of the fixed-sequence approach lies on its ability to provide a practical solution for problems with a large number of products, as it breaks up the difficult dynamic scheduling problem into two easier sub-problems, namely, sequencing and lot sizing, which are solved sequentially. A drawback of this approach, however, is that it may not respond effectively to random changes in demand, as was mentioned earlier.

The other approach, which we follow in this dissertation, is to develop a dynamic scheduling rule that determines which product to produce based on the current state of the system. Such a rule may be a simple heuristic or may be derived from an optimal control analysis of the problem. It may rely on only part of the current state of the system, e.g. on the inventory level of the product that the facility is set up for (local rule), or on the entire state of the system (global rule). Zipkin (1986) is an indicative example of a dynamic sequencing approach that uses a local (s, Q)-type lot sizing policy. The literature on dynamic sequencing approaches, particularly the track that adopts an optimal control perspective, is quite scarce, because of the insurmountable difficulty of obtaining an analytical solution even for problems of small size, and the computational challenge of numerically solving problems of realistic size.

One of the first exploratory works on the SELSP is Vergin and Lee (1978). They examine simple dynamic sequencing heuristics for the SELSP with changeover costs but no changeover times. The heuristic that outperforms all others is one where in each period, production switches to the product with the fewest expected remaining days of stock or most days of backorder, if that product has fewer days than a certain critical number of days of stock on hand. Else, if the product being produced does not exceed its maximum inventory level (absolute and relative), then its production is continuous in the next period; otherwise, the production facility is idled for the next period.

Graves (1980) looks at the SELSP as a discrete-time stochastic control problem with dynamic sequencing. He first solves a one-product problem with inventory-backorder costs and changeover costs, but no changeover times, where the decision in each period is to produce or idle the facility. He then uses the solution of the one-product problem as the basis for a heuristic procedure to solve the multi-product problem. In that heuristic, scheduling conflicts among different products are solved by comparing the value functions derived for each individual and “composite”

product from the one-product analysis. The composite product is a concept that Graves introduces to help anticipate possible scheduling conflicts in the multi-product problem. The idea is that the composite inventory of several products should indicate the need for current production, in case the individual product inventories are deemed just adequate when viewed in isolation.

Qiu and Loulou (1995) look at a problem with Poisson demand, deterministic processing and changeover times, and changeover and inventory-backlog costs. They model the problem as a semi-MDP, where the objective is to decide in each “review” epoch which product, if any, to set up the facility to produce, in order to minimize the infinite-horizon, discounted cost. The review epochs are those points in time when either the production facility is idle and some demand arrives, or when a part has just been processed and the production facility is free. They use successive approximation to generate near-optimal control policies by solving the problem on a truncated inventory space, and compute error bounds caused by the truncation. They present numerical results for 2-product problems, and conclude that systems with more than two products are limited by the curse of dimensionality.

Finally, Karmarkar and Yoo (1994) and Sox and Muckstadt (1997) develop finite-horizon stochastic mathematical programming models for the SELSP, that can also be classified as SCLSP, with deterministic production and changeover times, and use Lagrangian relaxation for finding optimal or near-optimal solutions for problems of small sizes.

There has also been a stream of works on the dynamic scheduling of failure-prone flexible manufacturing systems that are based on a flow control approach. In much of that literature, it is assumed that the production capacity changes randomly due to machine failures and repairs, while the demand rate remains constant.

Kimemia and Gershwin (1983) are among the first to show that the optimal control policy for such systems is a “hedging point” policy, according to which a positive surplus of products is

maintained during times of excess capacity availability to hedge against future capacity shortages that are brought about by machine failures.

When the manufacturing system is not perfectly flexible but requires setups, Sharifnia et al. (1991) propose a setup scheduling policy that uses “corridors” in the product surplus/backlog space to determine the timing of the setup changeovers in order to guide the trajectory in the desired direction. They investigate in detail the case where the desired trajectory leads to a hedging point, and show that in this case, the surplus/backlog trajectory at the setup level can lead to a limit cycle.

In a related work, Liberopoulos and Caramanis (1997) use an MDP approximation to find the optimal production rate and changeover policy of a single unreliable production facility with negligible or random changeover times to meet constant demand for two products, under various assumptions about the inventory holding and backorder cost rates. Their numerical results reveal that the optimal setup changeover policy is a corridor-type policy, where setup changeovers are initiated to keep the surplus/backlog state within a cone-type corridor, pointing towards an appropriately positioned hedging limit cycle.

In a parallel work, Elhafsi and Bai (1997) follow a similar approach for a similar 2-product system to show that the structure of the optimal setup changeover policy is a corridor-type policy too. In their case, the corridor is orthogonal or parallel, depending on the parameters of the system.

Our work in Chapter 3 follows the stream of papers that view the SELSP as a discrete-time, periodic-review control problem with dynamic production sequencing and global lot sizing, and as such is more closely related to Graves (1980) and Qiu and Loulou (1995). It is also very closely related to Sharifnia et al. (1991), Liberopoulos and Caramanis (1997), and Elhafsi and Bai (1997), as we use a qualitatively similar approach and obtain a similar corridor-type setup changeover policy, as we will see in Section 3.4. Our work differs from previous works in that it considers a new variant of the SELSP, where the FG inventory buffer has finite storage capacity and the only

allowable changeovers are from one grade to the next lower or higher grade. The latter feature renders problems with a large number of grades amenable to heuristic solution procedures that are based on approximating the original problem by several smaller (i.e., with fewer grades) sub-problems which are computationally easier to solve. We develop one such procedure in Section 3.3.

1.3 Dissertation organization

The remainder of this dissertation is organized into two main parts which occupy Chapters 2 and 3, respectively.

In Chapter 2, we develop a discrete-time, MILP model for the production scheduling of a continuous-process multi-grade PET resin plant. The objective is to minimize the cost associated with grade changeovers in order to avoid undesirable variations in base resin properties and process conditions that occur during such changes. The constraints of the model include requirements related to sequence-dependent changeovers, sequential processing with production and space capacity, mixed and flexible finite intermediate storage, and intermediate demand due-dates. We present a case study that illustrates the application of the model on a real problem scenario and provides insight into its behavior. The numerical experience demonstrates that the computational requirements of the model are quite reasonable for problem sizes that typically arise in practical applications.

In Chapter 3, we study a variant of the SELSP in which a single production facility must produce several different grades of a family of products to meet random stationary demand for each grade from a common Finished-Goods (FG) inventory buffer with limited storage capacity. Demand that can not be satisfied directly from inventory is lost. Raw material is always available, and the production facility continuously produces at a constant rate. When the facility is set up to produce a particular grade, the only allowable changeovers are from that grade to the next lower or

higher grade. All changeover times are constant and equal to each other. There is a changeover cost per changeover occasion, a spill-over cost per unit of product in excess whenever there is not enough space in the FG buffer to store the produced grade, and a lost-sales cost per unit short whenever there is not enough FG inventory to satisfy demand. We model the SELSP as a discrete-time MDP, where in each time period the decision is whether to initiate a changeover to a neighboring grade or keep the set up of the production facility unchanged, based on the current state of the system which is defined by the current set up of the facility and the FG inventory levels of all the grades. The goal is to minimize the (long-run) expected average cost per period. For 2- and 3-grade problems, we numerically solve the exact MDP problem using the value iteration method. For problems with more than three grades, we develop a heuristic solution procedure which is based on approximating the original multi-grade problem by several 3-grade sub-problems and numerically solving each sub-problem using value iteration. We present numerical results for problem examples with 2-5 grades. For the 2- and 3-grade examples, we use the exact solution procedure to obtain insights into the structure of the optimal changeover policy. For the 4- and 5-grade examples, we compare the performance of the heuristic solution procedure against that of the exact procedure.

Finally, we summarize our findings in Chapter 4.

Chapter 2 Production scheduling of a multi-grade PET resin plant

In this chapter, we develop a discrete-time, Mixed Integer Linear Programming (MILP) model for the production scheduling of a continuous-process multi-grade PET resin plant. The objective is to minimize the cost associated with grade changeovers in order to avoid undesirable variations in base resin properties and process conditions that occur during such changes. The constraints of the model include requirements related to sequence-dependent changeovers, sequential processing with production and space capacity, mixed and flexible finite intermediate storage, and intermediate demand due-dates. We present a case study that illustrates the application of the model on a real problem scenario and provides insight into its behavior. The numerical experience demonstrates that the computational requirements of the model are quite reasonable for problem sizes that typically arise in practical applications.

The rest of this chapter is organized as follows. In Section 2.1, we describe the operation of the PET resin plant that motivated this work. In Section 2.2, we present the MILP formulation that we developed for the scheduling problem under consideration. Section 2.3 illustrates the application of the model on a real problem scenario. Finally, we draw our conclusions in Section 2.4.

2.1 Operation of a PET plant

PET production is relatively simple in that yields are practically fixed and bygrade waste is minimal. The production process is non-stop and continuous, and consists of two stages in series: Liquid State (or Melt) Polymerization (POLY) and Solid State Polymerization (or Polycondensation) (SSP) which raises the molecular weight and hence the tensile properties of the fibers obtained by melt polymerization. Feed rate changes are possible but highly undesirable, because they cause variations in the production process and grade characteristics. A common industrial practice is to set the production rates of POLY and SSP equal to each other so that the material flow in the two stages is synchronized; if this were not the case, the storage area between them would eventually become either full (if POLY produced faster than SSP) or empty (if POLY produced at a lower rate than SSP), at which point one or both rates would have to change to avoid violating the buffer capacity constraint (typically, the two rates would be set equal to each other). Asynchronous material flow between consecutive production stages, which causes the material level in the storage space between the stages to change dynamically, has been studied quite extensively in the context of unreliable discrete-parts manufacturing (e.g., see the review paper by Dallery and Gershwin (1992)). In the continuous-flow setting that we consider in this dissertation, which is typical in the process industries, however, the material flow between the two processing stages is synchronized and the common production rate of the two stages may be tuned once in a while in the long run so as to match the total expected demand for all grades, in case the demand has seasonal or other long-run variations. For the purposes of short-term scheduling that we consider in this dissertation, however, the common production rate is assumed to be constant and equal to (or close to) the total expected demand for all grades. This assumption holds true in most real PET plants, including the one that inspired this study.

The final product or *grade* coming out of SSP is characterized by two key properties: Color and Intrinsic Viscosity (IV). IV is related to the length of the polymer chains; the higher the IV, the stiffer the material. The color is determined in the first production stage (POLY), while the IV is determined in the second stage (SSP). In the bottle-grade PET plant that inspired this work, there are four acceptable combinations of color and IV. These combinations lead to four final products, respectively, as shown in Table 2-1. A dash (-) denotes a color and IV combination that is not produced, because there is no demand for it. The abbreviations WG, SD, G and FH correspond to the grades Water Grade, Soft Drink, Gray, and Fast Heat, respectively.

Table 2-1. Grade of final product based on color and IV combination

IV	Color		
	Light (L)	Gray (G)	Dark (D)
Low (< 0.8)	WG	-	-
High (> 0.8)	SD	G	FH

WG is primarily used for water bottles. It is light-colored, because consumers are known to prefer clear and transparent water bottles. Moreover, it has low IV, because water bottles need not be as stiff as bottles for carbonated soft-drinks, which are under higher pressure. Carbonated soft drinks, on the other hand, are stored in high-IV bottles and can be either light-colored (SD), usually for light-colored soft drinks, or dark-colored (FH), usually for dark-colored soft drinks. From a production process viewpoint, dark-colored PET is preferable to light-colored PET, because it can produce bottles with more uniformly distributed mass density – hence, higher quality – faster, in the fast-heat and inflation molding stage of bottle making.

Grade changeovers are necessary in order to meet dynamic customer demand on time but are undesirable, because they last a significant amount of time and cause variations in base resin properties and processing conditions during the transition period. The only allowable grade

changeovers are from WG to SD to G to FH and backwards (always in this order). G is an intermediate off-specification grade produced inevitably during the color changeover transition from SD to FH and vice versa. Typically, there is no regular demand for it in the primary market for PET, but it can be sold in a secondary market at a lower price. Another type of intermediate grade is produced during the IV changeover transition from WG to SD and backwards. A common industrial practice, which is also employed by the plant that inspired this work, is to divide this intermediate grade into two halves and classify the first half as WG and the second half as SD. The opposite is done in a changeover transition from SD to WG. Therefore, the entire quantity of the intermediate grade is mixed in with the pure WG and SD grades and is sold in the primary market. In effect, however, this mixing lowers the overall on-specification grade percentage, and is therefore highly undesirable.

The two production stages, POLY and SSP, are separated by an intermediate storage area, which we refer to as Temporary Storage Stage (TSS) and typically consists of 2-3 silos (see Figure 2-1). One possible way of using these silos would be to dedicate them to the different color grades coming out of POLY. For example, if there were three TSS silos, then the first silo would be used for storing Light-colored (L) PET, the second for storing gray (G) PET, and the third for storing Dark-colored (D) PET. This way, if production were to change over, say, from light- to dark-colored PET, the material coming out of POLY would have to be redirected from silo L to silo G, during the color changeover transition period, and then to silo D upon the end of the transition. Similarly, if the final grade production were to change over from SD to FH, then the silo feeding the SSP reactor would have to be switched from L to D.

In effect, however, redirecting the feeds in and out of the TSS is not instantaneous but takes a small transition time during which the grades before and after the changeover are mixed, because the pipes in and out of the TSS must be emptied from one grade before they can be filled with the

next. To avoid this extra mixing, the plant that inspired this work actually uses only one of the silos in the TSS area, and reserves the other silos for special situations, such as for storing the product produced from POLY during an interruption of the SSP process caused by an unforeseen equipment failure or a scheduled maintenance. Thus, at any given time, the actively used silo in TSS has different layers of light-colored, gray, and dark-colored material stashed on top of each other.

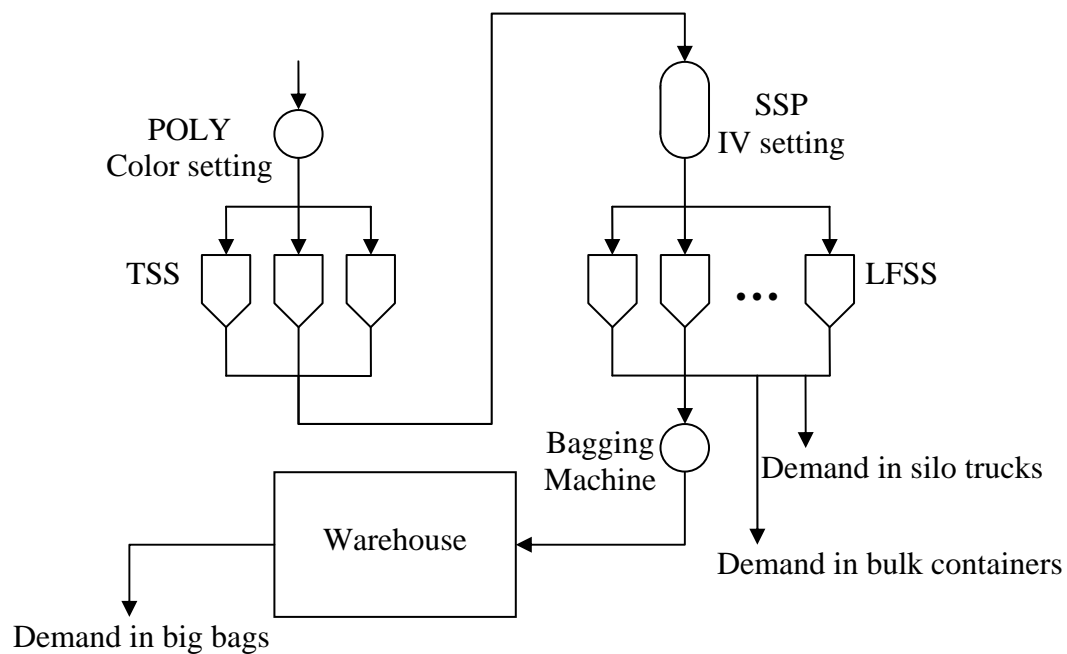

Figure 2-1. Material flow in a PET resin production plant

With this in mind, henceforth, we will assume that only one silo is actively used in TSS. This assumption eliminates the dilemma of which silo to feed POLY into, and which silo to feed SSP from; hence, it simplifies the scheduling problem. At the same time, however, it complicates the model, because one must keep track of the different layers of color present in the TSS silo. It is also worth mentioning that the SSP reactor is itself a silo with non-negligible space capacity, in which clean inert gas moves upward and chips downward. This means that material needs a

significant time to travel through the reactor, and therefore what goes in SSP comes out from it with a time delay. This adds another factor of complication to the model.

The grade coming out of SSP is loaded into one of several silos at the so-called Loading or Final Storage Stage (LFSS). Unlike the silos in the TSS, which allow the cohabitation of different colors, the silos in the LFSS do not. Thus, each silo can only contain a single final grade at any given time. There is a degree of flexibility, however, in that it is possible to switch the grade that a silo contains. In order for this to happen, though, the silo must first be completely emptied from one grade, before it starts being filled with another.

The grade coming out of the silos in LFSS is either filled into big bags with the use of a bagging machine and stored in a finished-goods warehouse, or is directly loaded into silo trucks or bulk containers to be shipped to customers. A different unloading rate applies for each of these three distinct unloading modes of the LFSS silos. Additionally, customers may also demand PET in big bags directly from the warehouse. In this case, the big bags are loaded onto regular trucks.

The scheduling model that we develop in this chapter minimizes the cost associated with the number of grade changeovers in a fixed time horizon, while also satisfying several constraints related to sequence-dependent changeovers, sequential processing with production and space capacity, mixed and flexible finite intermediate storage, and intermediate demand due-dates at both the LFSS and the warehouse. We adopt a discrete-time representation, which keeps the model relatively simple, enhances its flexibility and facilitates the introduction of additional constraints. Furthermore, our computational results demonstrate that our model can handle practical problem cases in quite reasonable times. Given the complexity of our model, which stems from the complexity of the real system that it represents, we doubt that a continuous-time representation would offer significant computational benefits.

The main input for the scheduling model is the initial setup state of POLY and SSP, the initial inventory level and grade-type in TSS, LFSS and the warehouse, and the demand forecast for each grade and transportation mode, in each period of the scheduling horizon. Given that the sales department of the plant that motivated the development of our model can forecast the demand quite accurately for a week ahead of time, a typical length of the scheduling horizon is one week. Within this horizon, several scheduling decisions must be addressed, such as which grade to produce and when to initiate a color or IV changeover transition, which LFSS silo to pour the grade coming out of SSP into, which LFSS silo to sack big bags from, if any, and which LFSS silo to load trucks or bulk containers from, to meet the demand.

The research presented in this chapter was conducted as part of a project entitled “Optimization of production scheduling and product distribution of a PET resin chemical plant,” as was mentioned in the acknowledgments section at the beginning of the dissertation. Having been developed for a real Operations Research (OR) application, our model is tailor-made, because it includes several features that are specific to this application and can not be incorporated into any of the general-purpose, discrete-time or continuous-time model formulations that have been proposed in the literature. These special features will become apparent in the following paragraphs, where we describe in detail the operation of the PET plant that motivated this work. At the same time, however, our model is general enough to be suitable for use in other similar applications, particularly those in the polymer production industry, after performing the appropriate adjustments.

There are several features of our model which we have not encountered in the literature on general-purpose MILP modeling in process scheduling. One such feature is that the changeover sequence in one stage depends on the setup state of the other stage. More specifically, according to Table 1, the changeover from low to high IV in SSP is not allowed, if the color setting of the material currently being processed in SSP is G or D. This complicates things considerably, since the

color of the material being processed in SSP in a particular time period has been determined several periods earlier when this material was processed in POLY. Moreover, as was also mentioned earlier, even though the changeover transition time from low to high IV (and reversely) is significant, in practice, the transition itself is conventionally considered to take place instantaneously in the middle of the transition time, as far as the classification of the grade produced by SSP is concerned. What complicates the model even more is that the SSP reactor has itself a finite space capacity which introduces a delay between what goes in and out of SSP.

Another special feature of our model is that layers of different color grades are allowed to be stored on top of each other in the active silo in TSS, making it necessary to keep track of these layers. Consequently, the storage requirements of that silo do not fall in any of the usual types of intermediate storage requirements encountered in the literature on MILP modeling in process scheduling, namely, unlimited, finite dedicated or flexible (but with no mixing allowed), zero-wait, and no storage requirements (e.g., see Shaik and Floudas (2007)). For this reason, we refer to these requirements as *mixed* finite intermediate storage requirements.

Additionally, the demand for final products does not only occur at different intermediate dates, but also at two different storage stages, namely, at the LFSS and at the warehouse. This makes the LFSS both an intermediate and a final storage area, raising the question “to sack or not to sack big bags,” because sacking big bags serves to increase the service level of customers requesting big bags from the warehouse but at the same time lowers the service level of customers requesting bulk material from the silos at the LFSS.

The above features complicate the mathematical formulation of our model but also make it more interesting and challenging. The real motivation for developing our model, however, stems from the fact that it is built for a real OR application. We present a case study that illustrates the application of the model on a real problem scenario and provides insight into its behavior. The

numerical experience that we provide demonstrates that the computational requirements of the model are quite reasonable for problem sizes that typically arise in practical applications.

2.2 MILP model development

For the needs of our model, we discretize time by dividing the scheduling horizon, typically one week, into a finite number of identical time periods. The length of each period must be no bigger than the length of the shortest nonstop event that takes place in the entire process. This could be the transition time of a grade changeover, the time of a shift, if different shifts have different characteristics, etc.

The production facility operates on a 24-hour basis, so in each period, POLY produces an amount of material which is equal to the constant production rate of the plant, denoted by P , multiplied by the length of the period; therefore, POLY is considered as a source of material (we assume that it is never starved of raw material), and the material that it produces in each period is referred to as a *lot*.

The next step is to discretize space at the TSS and SSP stages by dividing their capacities into an integer number of *slots*, where each slot accommodates exactly one lot. At the beginning of the scheduling horizon, the active silo in the TSS has some initial material in it that occupies several slots – say N slots – and the SSP reactor is filled with material up to its capacity, which is equal to, say, M slots. The SSP reactor has the same production rate as POLY, as was mentioned in Section 2.1; therefore, in each period, the TSS and the SSP stages consume from their upstream stage and release into their downstream stage exactly one lot. This implies that in every period of the scheduling horizon, the number of lots in TSS and SSP is constant and equal to N and M , respectively.

Note that if the production rates of POLY and SSP were allowed to be different, then we would have to keep track of the dynamically changing level of material (number of non-empty slots) in the TSS, as well as the type of material in each slot. In fact, this is more or less what we do in the case of the LFSS, where the input rate is constant but the output rate is partly variable and uncontrollable, due to the varying demand, and partly controllable, as the rate of bagging bulk material from the LFSS into big bags is a decision variable.

The color (L, G or D) of the lot in the n^{th} slot of the $N + M$ slots of the TSS and the SSP reactor taken together depends on the setup state (L, G or D) of POLY n periods before the beginning of the time horizon. Therefore, in order to characterize the color in the $N + M$ slots of the TSS and the SSP reactor, we need to know the setup state of POLY during the last $N + M$ periods before the beginning of the scheduling horizon. With this in mind, we shift the time axis by $N + M$ periods so that the first period of the scheduling horizon is $N + M + 1$, and therefore periods 1 to $N + M$ refer to the past.

Next, we present the MILP formulation that we developed for the problem under consideration. The following notation is used:

Sets:

I : set of colors produced by POLY, indexed by i , $I = \{1, 2, 3\} \equiv \{L, G, D\}$

J : set of final grades, indexed by j , $J = \{1, 2, 3, 4\} \equiv \{WG, SD, G, FH\}$

Q : set of silos in LFSS, indexed by q

Parameters:

T : index of the last period of the scheduling horizon

P : production quantity of the process in one period

N : number of slots in TSS

M : number of slots in SSP

- d : cost incurred per color changeover at POLY
- c : cost incurred per IV changeover at SSP
- B : duration of a color changeover transition at POLY (in number of periods)
- F : duration of an IV changeover transition at SSP (in number of periods)
- XO_{1t} : binary parameter that takes the value 1 if the lot produced by POLY in period t has color L, and 0 otherwise, $t = 1, \dots, N + M$
- XO_{2t} : binary parameter that takes the value 1 if the lot produced by POLY in period t has color G, and 0 otherwise, $t = 1, \dots, N + M$
- XO_{3t} : binary parameter that takes the value 1 if the lot produced by POLY in period t has color D, and 0 otherwise, $t = 1, \dots, N + M$
- AO_t : binary parameter that takes the value 1 if an IV change is initiated at the beginning of period t , and 0 otherwise, $t = N + M - F + 2, \dots, N + M$
- ZO : binary parameter that takes the value 1 if the IV of the lot stored in the last slot of SSP at the beginning of the scheduling horizon is high, and 0 otherwise
- WO_{qj} : binary parameter that takes the value 1 if grade j is stored in silo q of LFSS at the beginning of the scheduling horizon, and 0 otherwise
- SO_{qj} : quantity of grade j contained in silo q of LFSS at the beginning of the scheduling horizon
- S_{max} : capacity of a silo in LFSS
- S_{min} : minimum quantity of a nonempty silo in LFSS
- $SS_{min j}$: safety stock of grade j in LFSS at the end of the scheduling horizon
- u_{ST} : maximum quantity of material that can be loaded from LFSS into a silo truck in one period
- u_{BC} : maximum quantity of material that can be loaded from LFSS into a bulk container in one period
- u_{BB} : maximum quantity of material that can be sacked from LFSS into big bags in one period

$R0_j$: grade j inventory in the warehouse at the beginning of the scheduling horizon

R_{max} : warehouse capacity

R_{min_j} : safety stock of grade j in the warehouse at the end of the scheduling horizon

dST_{jt} : silo trucks demand of grade j in period t , $t = N + M + 1, \dots, T$

dBC_{jt} : bulk containers demand of grade j in period t , $t = N + M + 1, \dots, T$

dBB_{jt} : big bags demand of grade j in period t , $t = N + M + 1, \dots, T$

Decision Variables:

x_{it} : binary decision variable that takes the value 1 if the lot produced by POLY in period t has color i , and 0 otherwise, $t = 1, \dots, T$

y_{jt} : binary decision variable that takes the value 1 if final grade j is produced by SSP in time period t , and 0 otherwise, $t = N + M + 1, \dots, T + (F/2)$

a_t : binary decision variable that takes the value 1 if an IV changeover is initiated at the beginning of period t , and 0 otherwise, $t = N + M - F + 2, \dots, T$

z_t : binary decision variable that takes the value 1 if the IV of the grade produced in period t is high, and 0 otherwise, $t = N + M, \dots, T + (F/2)$

S_{qjt} : quantity of grade j in silo q of LFSS at the end of period t , $t = N + M, \dots, T$

W_{qjt} : binary decision variable that takes the value 1 if grade j is contained in silo q of LFSS in period t , and 0 otherwise, $t = N + M, \dots, T$

g_{qjt} : binary decision variable that takes the value 1 if grade j is loaded from SSP into silo q of LFSS in period t , and 0 otherwise, $t = N + M + 1, \dots, T$

G_{qjt} : quantity of grade j that is unloaded from silo q of LFSS in period t , $t = N + M + 1, \dots, T$

b_{qjt} : quantity of grade j that is loaded from silo q of LFSS into big bags in period t , $t = N + M + 1, \dots, T$

f_{qjt} : quantity of grade j that is loaded from silo q of LFSS into silo trucks in period t , $t = N + M + 1, \dots, T$

$1, \dots, T$

h_{qjt} : quantity of grade j that is loaded from silo q of LFSS into bulk containers in period t , $t = N + M + 1, \dots, T$

R_{jt} : quantity of grade j in the warehouse at the end of period t , $t = N + M, \dots, T$

The formulation that we develop next also assumes that the following inequalities hold: $F < N + M$, $B < N + M$, $N + M < T - (N + M)$. These restrictions hold in practice.

The objective function of our model is expressed as

$$\text{Minimize } c \left(\sum_{t=N+M+1}^T a_t \right) + d \left(\frac{1}{B} \sum_{t=N+M+1}^T x_{2t} \right) \quad (2.1)$$

The above expression minimizes the weighted sum of the number of IV and color changeovers during the scheduling horizon, i.e., from period $N + M + 1$ to period T . The first summation in the objective function represents the number of IV changeovers. The second summation represents the total number of color changeover transition periods. It is divided by B , i.e., by the duration of a color changeover transition, to give the number of color changeovers.

Next, we present the constraints of our model. Constraints (2.2)-(2.11) are related to the processing part of the plant, which comprises POLY, TSS and SSP.

$$\sum_{i \in I} x_{it} = 1, t = 1, \dots, T \quad (2.2)$$

$$\left. \begin{array}{l} x_{1t} + x_{3t+p} \leq 1 \\ x_{3t} + x_{1t+p} \leq 1 \end{array} \right\}, t = 1, \dots, T - 1, p = 1, \dots, \min(T - t, B) \quad (2.3)$$

$$\left. \begin{array}{l} y_{1t} + y_{3t+1} \leq 1 \\ y_{3t} + y_{1t+1} \leq 1 \end{array} \right\}, t = N + M + 1, \dots, T + (F/2) - 1 \quad (2.4)$$

Constraint set (2.2) states that POLY can only produce a single color in each period. Since the color of the final grade exiting SSP in any period was determined in POLY $N + M$ periods earlier, at the beginning of the scheduling horizon, the color in slots $1, \dots, N + M$ has already been

predetermined; therefore, in effect, constraint (2.2) must really be imposed from period $N + M + 1$ and on only. Its application to periods $1, \dots, N + M$ is merely a routine check that serves to verify that the initial status of the system, as decided in the previous scheduling horizon, results in feasible production settings during the present horizon, too. This modeling technique is also adopted in several of the other model constraints which follow.

Constraint set (2.3) states that between two periods in which POLY produces colors L and D (in either order), B periods in which POLY produces G must always intervene. Note that the actual number of constraints of this set depends not only on the length of the scheduling horizon but also on the value of B . More specifically, if $B = 1$, then POLY can not produce colors D and L in two adjacent periods. If $B > 1$, this restriction is imposed not only to adjacent periods, but also to periods that are spaced i periods apart, for $i = 2, \dots, B$.

Similarly, constraint set (2.4) states that final grades WG and G can not be produced in two adjacent periods, because at least one period in which grade SD is produced must always intervene. Since the color is determined in POLY and any IV change in SSP becomes effective $F/2$ periods after it is initiated, the final grade that will be produced in the first $F/2$ periods of the scheduling horizon, i.e., in periods $N + M + 1, \dots, N + M + (F/2)$, is predetermined by the initial state of the system. Therefore, constraint set (4) must really be imposed from period $N + M + (F/2)$ and on only. Its application to periods $N + M, \dots, N + M + (F/2) - 1$ serves to verify that the initial conditions are feasible. To ensure that the current production schedule will also remain feasible in the next scheduling horizon, this set of constraints also extends to periods $T + 1, \dots, T + (F/2) - 1$. Combined together, constraint sets (2.3) and (2.4) ensure that the only allowable grade changeovers are from WG to SD to G to FH and backwards, always in this exact sequence.

$$\sum_{s=t}^{t+F-1} a_s \leq 1, \quad t = N + M - F + 2, \dots, T - F + 1 \quad (2.5)$$

$$a_t \leq x_{1t-N-M}, t = N + M + 1, \dots, T \quad (2.6)$$

$$\left. \begin{array}{l} z_{t+(F/2)} - z_{t+(F/2)-1} \leq a_t \\ z_{t+(F/2)} - z_{t+(F/2)-1} \geq -a_t \end{array} \right\}, t = N + M + 1 - (F/2), \dots, T \quad (2.7)$$

$$\left. \begin{array}{l} z_{t+(F/2)} + z_{t+(F/2)-1} \geq a_t \\ z_{t+(F/2)} + z_{t+(F/2)-1} \leq 2 - a_t \end{array} \right\}, t = N + M + 1 - (F/2), \dots, T \quad (2.8)$$

Constraint set (2.5) states that only one IV change can be initiated at SSP within F consecutive periods. This constraint stems from the fact that an IV change in the SSP reactor lasts F periods in total, and can not be interrupted before it is fully completed. The grade produced by SSP during the first $F/2$ periods after an IV changeover is initiated is considered to have the characteristics of the grade that was produced before the beginning of the changeover transition, while the grade being produced during the last $F/2$ periods is considered to have the characteristics of the grade that will be produced after the end of the transition. Therefore, F is only limited to even integers.

Constraint set (2.6) states that an IV changeover can only be initiated if the color of the grade currently being produced is L, because, as can be seen from Table 2-1, no IV changeover is possible when the color setting is G or D. Constraint sets (2.7) and (2.8) ensure that if an IV changeover is initiated at the beginning of period t , then this change becomes effective in period $t + (F/2)$ and onward. If $a_t = 0$, constraint set (2.8) is redundant, and constraint set (2.7) reduces to $z_{t+(F/2)} = z_{t+(F/2)-1}$, ensuring that the IV remains unchanged. On the other hand, if $a_t = 1$, constraint set (2.7) is redundant, and constraint set (2.8) reduces to $z_{t+(F/2)} + z_{t+(F/2)-1} = 1$, ensuring that the IV changes at the beginning of period $t + (F/2)$.

To help clarify matters, a pictorial representation of the relationship between variables x_{it} , y_{jt} and z_t is shown in Figure 2-2. The top part of that figure is a snapshot of the contents of POLY, TSS and SSP at the end of the last period before the beginning of the scheduling horizon, i.e., at the end

of period $N + M$. As shown in this snapshot, the color of the lots occupying slots 1 to $N + M$ has already been predetermined. For example, the color of the lot in slot $N + M$ was determined in period 1 and is given by vector $\mathbf{x}_1 \equiv (x_{11}, x_{21}, x_{31})$. The bottom part of Figure 2-2 shows the contents of POLY, TSS and SSP at the end of the first period of the scheduling horizon, i.e., period $N + M + 1$. As shown in this schematic representation, each lot has advanced by one slot. As a result, the lot that occupied the last slot of SSP has exited SSP. Its grade, which is given by vector $\mathbf{y}_{N+M+1} \equiv (y_{1N+M+1}, y_{2N+M+1}, y_{3N+M+1}, y_{4N+M+1})$, is a combination of its color, which was determined in period 1 by the value of \mathbf{x}_1 , and its IV, which is determined in period $N + M + 1$ by the value of z_{N+M+1} .

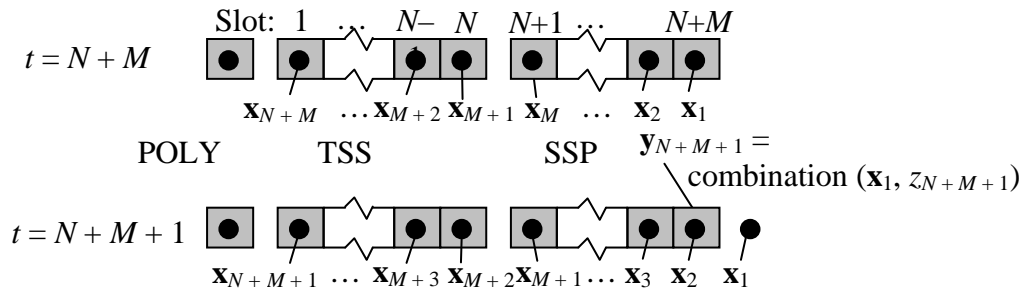

Figure 2-2. Time shift representation in the production process

$$\left. \begin{array}{l} x_{2\ t-N-M} \leq z_t \\ x_{3\ t-N-M} \leq z_t \end{array} \right\}, t = N + M + 1, \dots, T + (F/2) \quad (2.9)$$

$$\left. \begin{array}{l} y_{1t} \geq x_{1\ t-N-M} - z_t \\ y_{2t} \geq z_t + x_{1\ t-N-M} - 1 \\ y_{3t} \geq z_t + x_{2\ t-N-M} - 1 \\ y_{4t} \geq z_t + x_{3\ t-N-M} - 1 \end{array} \right\}, t = N + M + 1, \dots, T + (F/2) \quad (2.10)$$

$$\sum_{j \in J} y_{jt} = 1, t = N + M + 1, \dots, T + (F/2) \quad (2.11)$$

Constraint set (2.9) is introduced to ensure that colors G and D can only be combined with

high IV. Constraint set (2.10) determines the final grade based on the combination of color and IV, while constraints (2.11) state that only a single grade can be produced in any period of the scheduling horizon. If status verification is not necessary, constraints (2.9)-(2.11) can be applied from period $N + M + (F/2) + 1$ and on.

Constraint sets (2.12)-(2.29) are related to the storage part of the plant, which comprises LFSS and the warehouse.

$$g_{qjt} \leq W_{qjt}, q \in Q, j \in J, t = N + M + 1, \dots, T \quad (2.12)$$

$$\sum_q g_{qjt} \leq y_{jt}, j \in J, t = N + M + 1, \dots, T \quad (2.13)$$

$$\sum_{q \in Q} \sum_{j \in J} g_{qjt} = 1, t = N + M + 1, \dots, T \quad (2.14)$$

$$\sum_{j \in J} W_{qjt} \leq 1, q \in Q, t = N + M + 1, \dots, T \quad (2.15)$$

$$W_{qjt+1} - W_{qjt} \leq 1 - \sum_{r \in J} W_{qrt}, q \in Q, j \in J, t = N + M, \dots, T - 1 \quad (2.16)$$

Constraint set (2.12) ensures that in each period, grade j can not be loaded from SSP into silo q of the LFSS, unless this silo already has grade j in it at the beginning of this period. Constraint (2.13) ensures that in each period, the grade loaded into any silo of the LFSS is the same with the grade that is being produced by SSP in the same period. Constraint set (2.14) ensures that in each period, a single grade will be loaded from SSP into a single silo of LFSS. Constraint set (2.15) states that in each period, each silo of the LFSS can store at most one grade.

Constraint set (2.16) states that the grade stored in a silo of the LFSS can not change unless a period in which this silo is empty intervenes. The summation $\sum_{r \in J} W_{qrt}$ is equal to 1 when silo q contains some final grade in period t , and 0 if it is empty. Thus, a difference equal to 0 in the right-hand side forces the difference in the left-hand side to be 0, ensuring that any grade j which is different from the one that was contained in the silo in the previous period, can not be poured in this

silo before it is completely emptied. Note that index j is used in both terms of the left-hand side to disclose whether a *particular* grade j can be poured into silo q in period $t + 1$, while r is used in the right-hand side to disclose whether silo q contained *any* final grade r in the previous period.

$$S_{qjt} \leq S_{\max} W_{qjt}, q \in Q, j \in J, t = N + M + 1, \dots, T \quad (2.17)$$

$$S_{qjt} \geq S_{\min} W_{qjt}, q \in Q, j \in J, t = N + M + 1, \dots, T \quad (2.18)$$

$$G_{qjt} \leq W_{qjt} \max(u_{ST}, u_{BC}, u_{BB}), q \in Q, j \in J, t = N + M + 1, \dots, T \quad (2.19)$$

$$S_{qjt} = S_{qjt-1} + g_{qjt} P - G_{qjt}, q \in Q, j \in J, t = N + M + 1, \dots, T \quad (2.20)$$

$$\sum_{q \in Q} S_{qjT} \geq SS_{\min j}, j \in J \quad (2.21)$$

Constraint set (2.17) states that the grade quantity stored in a silo can not exceed the silo's capacity, and ensures that it will be zero whenever the corresponding variable W determines that this silo is empty. Constraint set (2.18) imposes a lower bound on the quantity of a nonempty silo. It is introduced to eliminate the situation in which a silo stores a negligible but positive grade quantity. Constraint set (2.19) states that no grade can be unloaded from an empty silo and imposes the maximum rate in which a silo can be unloaded, based on the values of variables u . Constraint set (2.20) ensures flow continuity, by updating the quantity stored in each silo, based on the quantity that it contained in the previous period, and the quantities loaded into and out of it in the next period. Note that the quantity produced by POLY and SSP in one period and all the quantities that can be unloaded or sacked from the LFSS depend on the period length. Constraint set (2.21) ensures that the total inventory of each grade in the LFSS is at or above the specified safety stock for that grade at the end of the scheduling horizon.

$$G_{qjt} = f_{qjt} + h_{qjt} + b_{qjt}, q \in Q, j \in J, t = N + M + 1, \dots, T \quad (2.22)$$

$$\frac{1}{u_{ST}} f_{qjt} + \frac{1}{u_{BC}} h_{qjt} + \frac{1}{u_{BB}} b_{qjt} \leq 1, q \in Q, j \in J, t = N + M + 1, \dots, T \quad (2.23)$$

$$dST_{jt} = \sum_{q \in Q} f_{qjt}, j \in J, t = N + M + 1, \dots, T \quad (2.24)$$

$$dBC_{jt} = \sum_{q \in Q} h_{qjt}, j \in J, t = N + M + 1, \dots, T \quad (2.25)$$

$$\sum_{q \in Q} \sum_{j \in J} b_{qjt} \leq u_{BB}, t = N + M + 1, \dots, T \quad (2.26)$$

$$R_{jt} = R_{jt-1} + \sum_{q \in Q} b_{qjt} - dBB_{jt}, j \in J, t = N + M + 1, \dots, T \quad (2.27)$$

$$\sum_{j \in J} R_{jt} \leq R_{\max}, t = N + M + 1, \dots, T \quad (2.28)$$

$$R_{jT} \geq R_{\min j}, j \in J \quad (2.29)$$

Constraint set (2.22) states that, in each period, the total quantity of grade j unloaded from any silo of the LFSS is equal to the quantity that is loaded into silo trucks or bulk containers, or sacked into big bags and stored in the warehouse. Constraint set (2.23) defines the maximum unloading rate of any silo, based on the exact unloading mode. Constraint sets (2.24) and (2.25) ensure that the demand for silo trucks and bulk containers is satisfied for each period of the scheduling horizon. Constraint set (2.26) ensures that the maximum sacking rate is not exceeded. Note that, while several silos can be used simultaneously for loading silo trucks or bulk containers, bagging can only take place in one silo, because only one bagging machine is available. Constraint set (2.27) updates the inventory stored in the warehouse, and constraint set (2.28) ensures that the total grade quantity stored in the warehouse does not exceed its capacity. Finally, constraint set (2.29) ensures that the inventory of each grade in the warehouse is at or above the specified safety stock at the end of the scheduling horizon.

Constraints (2.30)-(2.35) initialize the state of the system at the beginning of the scheduling horizon.

$$x_{it} = X0_{it}, i \in I, t = 1, \dots, N + M \quad (2.30)$$

$$z_{N+M} = Z0 \quad (2.31)$$

$$a_t = A0_t, t = N + M - F + 2, \dots, N + M \quad (2.32)$$

$$S_{qjt} = S0_{qj}, q \in Q, j \in J, t = N + M \quad (2.33)$$

$$W_{qjt} = W0_{qj}, q \in Q, j \in J, t = N + M \quad (2.34)$$

$$R_{jt} = R0_j, j \in J, t = N + M \quad (2.35)$$

More specifically, constraint sets (2.30)-(2.32) initialize the state of the production system at the beginning of the scheduling horizon. Note that, at the beginning of the scheduling horizon, the color has already been predetermined for all the in-process lots in TSS and SSP. Therefore, one needs to initialize the values of variables x_{it} , $i \in I$, for $t = 1$ to $N + M$. Also, the initialization of variables a_t for the last $F - 1$ periods is required, since at most one IV change can be initiated within F consecutive periods. Note, however, that at the beginning of the scheduling horizon, the IV has already been predetermined for the last $F/2$ slots of the SSP reactor only, since it takes $F/2$ periods for an IV changeover to take place. Yet, only the value of variable z_t , for $t = N + M$ needs to be initialized, since the remaining $(F/2) - 1$ values are determined through constraint sets (2.7)-(2.8) and variables a_t . As a consequence, the final grade that will be produced in the first $F/2$ periods of the scheduling horizon is already predetermined, too. Constraint sets (2.33)-(2.35) initialize the inventories in the LFSS silos and the warehouse at the beginning of the scheduling horizon.

$$x_{it} \text{ binary}; i \in I, t = 1, \dots, T \quad (2.36)$$

$$y_{jt} \text{ binary}; j \in J, t = N + M + 1, \dots, T + (F/2) \quad (2.37)$$

$$a_t \text{ binary}; t = N + M - F + 2, \dots, T \quad (2.38)$$

$$z_t \text{ binary}; t = N + M, \dots, T + (F/2) \quad (2.39)$$

$$w_{qjt} \text{ binary}; q \in Q, j \in J, t = N + M, \dots, T \quad (2.40)$$

$$g_{qjt} \text{ binary}; q \in Q, j \in J, t = N + M + 1, \dots, T \quad (2.41)$$

$$G_{qjt} \geq 0, q \in Q, j \in J, t = N + M + 1, \dots, T \quad (2.42)$$

$$R_{jt} \geq 0, j \in J, t = N + M, \dots, T \quad (2.43)$$

$$S_{qjt} \geq 0, q \in Q, j \in J, t = N + M, \dots, T \quad (2.44)$$

$$b_{qjt} \geq 0, q \in Q, j \in J, t = N + M + 1, \dots, T \quad (2.45)$$

$$f_{qjt} \geq 0, q \in Q, j \in J, t = N + M + 1, \dots, T \quad (2.46)$$

$$h_{qjt} \geq 0, q \in Q, j \in J, t = N + M + 1, \dots, T \quad (2.47)$$

Finally, constraint sets (2.36)-(2.41) and (2.42)-(2.47) impose the integrality and the nonnegativity of the decision variables, respectively. Note that the indexing of variables y_{jt} begins from $t = N + M + 1$ instead of $t = N + M + (F/2) + 1$, in order to keep record of the final grade produced during the first $F/2$ periods, too, which was actually determined by the production schedule of the previous horizon.

Note that in the above formulation we have assumed that at the beginning of the scheduling horizon, the plant is in the state that it was left off at the end of the previous horizon, because this is the usual situation encountered in practice. There also exists the situation where the plant is just beginning its operations after a long shutdown, in which case, all the slots of TSS and SSP are empty and possibly the silos and the warehouse are at very low or even zero levels. This situation is very rare in practice and is typically encountered after a major breakdown or after the yearly maintenance of the plant. When the plant is starting up after a long shutdown, the main concern is to stabilize the process and get the production going, rather than solving the scheduling problem. In principle, however, our model can still address the scheduling problem during the startup (or warm up) period, by letting period 1 (instead of period $N + M + 1$) be the first period of the scheduling horizon and appropriately adjusting the sets of time indices for which the constraints hold.

Also note that constraint sets (2.24), (2.25) and (2.27) ensure that the demand for silo trucks, bulk containers and big bags is satisfied for each period of the scheduling horizon. The strict requirement for on-time satisfaction of the demand stems from the current practice of the plant that motivated this work. Specifically, the customers of the plant schedule to send their own (or third party) trucks or containers to pick up their orders on specific periods, and can not afford to wait. This requirement may seem restrictive, because it may lead to infeasibilities, but in practice, it does not pose a problem, because the capacities of the LFSS and the warehouse are big enough to absorb any reasonable variations in the demand. Moreover, the careful choice of safety stock levels for each grade and inventory stage (LFSS and warehouse) can help minimize the number of changeovers in the long run, while preventing stockouts and production process blocking due to the lack of storage space. In the following section, we present an application in which we set the scheduling horizon equal to one week that is discretized into 42 4-hour periods, and solved our model sequentially 24 times (weeks), i.e., for a total of 6 months, where at the beginning of each week, the state of the system was set equal to the state that it ended up in the previous week. We used real demand data for each week, and we did not encounter any infeasibility problems. The safety stock levels were carefully chosen by modeling and solving the continuous-process scheduling problem as a Stochastic Economic Lot Scheduling Problem (SELSP), as described in Chapter 3.

Still, in applications where the on-time satisfaction of demand is not a strict requirement, we can easily modify our model, by including in the objective function the following penalty cost term for not satisfying the demand on time:

$$e \left(\sum_{t=N+M+1}^T \sum_{j \in J - \{3\}} \sum_{\tau=N+M+1}^t \left[\left(dST_{j\tau} - \sum_{q \in Q} f_{qj\tau} \right) + \left(dBC_{j\tau} - \sum_{q \in Q} h_{qj\tau} \right) + \left(dBB_{j\tau} - db_{j\tau} \right) \right] \right),$$

where e denotes the stockout penalty cost coefficient, and db_{jt} denotes the quantity of product j that is used to satisfy the demand for big bags in period t . In this case, constraints (2.24), (2.25) and (2.27) need to be modified, as follows:

$$\sum_{\tau=N+M+1}^t dST_{j\tau} \geq \sum_{\tau=N+M+1}^t \sum_{q \in Q} f_{qj\tau}, j \in J, t = N + M + 1, \dots, T$$

$$\sum_{\tau=N+M+1}^t dBC_{j\tau} \geq \sum_{\tau=N+M+1}^t \sum_{q \in Q} h_{qj\tau}, j \in J, t = N + M + 1, \dots, T$$

$$R_{jt} = R_{j,t-1} + \sum_{q \in Q} b_{qjt} - db_{jt}, j \in J, t = N + M + 1, \dots, T$$

and the following constraint must be added to the model:

$$\sum_{\tau=N+M+1}^t dBB_{j\tau} \geq \sum_{\tau=N+M+1}^t \sum_{q \in Q} db_{qj\tau}, j \in J, t = N + M + 1, \dots, T.$$

Finally, we may further modify our model in a similar manner, by replacing the hard constraints (2.21) and (2.29), which require that the inventory levels at the end of the horizon be no less than the safety stock levels, with an extra term in the objective function, that penalizes any negative deviations of the inventory levels at the end of the horizon from the safety stock levels.

2.3 Application of the model

In this section, we illustrate the application of the MILP model that we developed in the previous section on a problem instance drawn from the operation of the plant that inspired this work. The production rate of the facility is 200 tons/day, which is what the plant uses most of the time, although in the long run it can vary between 180 and 220 tons/day. The color changeover transition time between L and D in POLY is 4 hours, while the IV changeover transition between low and high IV in SSP is 24 hours. Both transition times are divisible by 4; hence, for the purposes of time discretization, we use a 4-hour time period. This makes $B = 1$, $F = 6$, and the production rate equal

to 33.3 tons/period. Note that a 4-hour period is also convenient because it is a divisor of a 24-hour day and of a typical 8-hour work-shift.

The active silo at the TSS has a capacity of 430 tons but is usually less than half full. With this in mind, we assume that at the beginning of the scheduling horizon it has 200 tons of material in it. This initial quantity can be divided into $N = 6$ identical slots, each with a capacity of 33.33 tons (the amount produced in a period). Similarly, the SSP reactor, which has a capacity of 200 tons, can be divided into $M = 6$ identical slots, each with a capacity of 33.33 tons.

In the actual operation of the plant, production is scheduled on a weekly basis, because at the end of each week, the demand during the following week is known with certainty. With this in mind, we use a scheduling horizon of one week, i.e., 42 time periods. Given that $N = M = 6$, the first period of the scheduling horizon is period 13 ($= N + M + 1$), and the last period, T , is period 54 ($= N + M + 42$). The values of the other problem parameters are $Z0 = 1$, $S_{max} = 430$ tons, $S_{min} = 1$ ton, $R_{max} = 3500$ tons, $u_{ST} = 224$ tons, $u_{BC} = 69.2$ tons, $u_{BB} = 40$ tons, $c = 1$, $d = 1$.

We solved the MILP model sequentially, for 24 weeks, i.e., 6 months, using real demand data. For space consideration, the demand values for each period are shown in Appendix A. In Table 2-2, we show the sample mean and standard deviation of the daily demand, for each grade and demand type. Note that the total mean daily demand for all grades and types is ~195 tons, which is slightly below the production rate of 200 tons per day. This small difference between production capacity and demand is due to the unavoidable production of grade 3 (G), which takes away some of the production capacity. As was mentioned earlier, there is no scheduled demand for grade G; in reality, however, the plant occasionally removes the accumulated inventory of grade G by selling it at a lower price to interested buyers. Also, note that grade 2 (SD) is only demanded in big bags.

Table 2-2. Sample mean and standard deviation of the daily demand for each grade and demand type

Grade j	1		2		4		Sum of means
	mean	std. dev.	mean	std. dev.	mean	std. dev.	
Demand in silo trucks	25.82	41.00	0	0	17.67	29.52	43.49
Demand in bulk containers	29.96	41.52	0	0	16.13	19.63	46.09
Demand in big bags	25.27	32.15	45.43	58.45	34.37	46.77	105.07
Total	81.05		45.43		68.17		194.65

In each week (run), the state of the system at the beginning of the scheduling horizon was set equal to the state of the system at the end of the previous run. The system at the beginning of the scheduling horizon of the first run was set to some reasonable initial state, which we do not show here for space considerations.

To obtain reasonable values for the safety stock levels, we modeled the scheduling problem as an SELSP, as in Chapter 3, and solved it numerically. We then used the results of the SELSP solution to compute the safety stock levels. The details of these computations are shown in the next section.

2.3.1 Computation of safety stock levels

In this section, we present a methodology for computing the safety stock levels for the LFSS silos and the warehouse. This methodology is based on modeling the continuous-process scheduling problem as a simple SELSP (see Chapter 3), solving that problem, and using its solution.

More specifically, in Chapter 3, we study a variant of the SELSP in which a single production facility must produce several grades to meet random stationary demand for each grade from a common FG inventory buffer with limited storage capacity. Demand that can not be satisfied directly from inventory is lost. Raw material is always available, and the production facility produces at a constant rate. When the facility is set up to produce a particular grade, the only

allowable changeovers are from that grade to the next lower or higher grade. All changeover times are deterministic and equal to each other. There is a changeover cost per changeover occasion, a spill-over cost per unit of product in excess, whenever there is not enough space in the FG buffer to store the produced grade, and a lost-sales cost per unit short, whenever there is not enough FG inventory to satisfy demand. We model the SELSP as a discrete-time Markov Decision Process (MDP), where in each time period it must be decided whether to initiate a changeover to a neighboring grade or keep the setup of the production facility unchanged, based on the current state of the system, which is determined by the current setup of the facility and the FG inventory levels of all the grades. The goal is to minimize the infinite-horizon expected average cost. For 2-grade and 3-grade problems we numerically solve the resulting MDP problem using successive approximations. The solution includes the optimal state-dependent policy and the optimal differential cost (value function) for each state of the system. The optimal policy partitions the state space into different regions, each characterized by a different optimal changeover action. The FG inventory levels at which the value function is minimized for a given setup state are the “ideal” target inventory levels for that setup state and in that sense can be thought of as the optimal safety stock levels for that state. In other words, the optimal safety stock levels really depend on the setup state of the facility.

We used the above methodology to find the optimal safety stock levels for a 3-grade system, where the three grades are WG, SD, and FH. To this end, we discretized the inventory space and time, and we used a demand distribution for each grade based on the real demand data for 6 months that we had available, without differentiating between the individual types of demand (silo trucks, bulk containers and big bags). The optimal safety stock level of grade j , when the facility is set up to produce grade i , denoted by $I_{\min,i,j}$, is shown in Table 2-3. Note that the safety stock levels strongly depend on the setup of the facility. For example, the safety stock level for WG is only 60

tons, if the facility is setup to produce WG, but goes up all the way to 1410 tons, if the facility is setup to produce FH.

Table 2-3. Optimal safety stock level of grade j , when the facility is set up to produce grade i , $I_{\min,i,j}$

Grade j	WG	SD	FH
$I_{\min,WG,j}$	60	660	1410
$I_{\min,SD,j}$	660	90	930
$I_{\min,FH,j}$	1410	1680	90

In the MILP formulation that we developed in this chapter, we assumed for simplicity that the safety stock levels do not depend on the setup state of the system. With this in mind, we used the results of Table 2-3 to compute a weighted average safety stock level for each grade j over all setup states, denoted by $I_{\min,j}$, where as weight for each setup state we used the percentage of time that the facility is set up in that state, given by its market share. Thus, if we let $E[d_j]$ denote the mean daily demand (see Table 2-2) and p_j denote the market share of grade j , we have

$$I_{\min,j} = \sum_{i \in \{WG,SD,FH\}} p_j I_{\min,i,j}, j \in \{WG, SD, FH\}$$

where

$$p_j = E[d_j] / \sum_{k \in \{WG,SD,FH\}} E[d_k], j \in \{WG, SD, FH\}$$

$$E[d_j] = E_t[dST_{jt}] + E_t[dBC_{jt}] + E_t[dBB_{jt}], j \in \{WG, SD, FH\}$$

The results of the above computations are shown in Table 2-4.

Table 2-4. Mean daily demand, $E[d_j]$, market share, p_j , and safety stock level, $I_{\min,j}$, for each grade j

Grade j	WG	SD	FH
$E[d_j]$	81.05	45.43	68.17
p_j	0.4164	0.2334	0.3502
$I_{\min,j}$	672.83	884.17	835.69

Finally, in the MILP formulation that we developed in this chapter, we assumed that the safety stock levels depend on the FH inventory stage (LFSS or warehouse) of the system, whereas in the SELSP formulation and solution it was assumed that there is a single FG inventory stage. With this in mind, we allocated the safety stock level, $I_{\min,j}$, shown in Table 2-4, to the LFSS silos and to the warehouse in proportion to their demand share. Thus, if we let $p_{\text{LFSS},j}$ and $p_{\text{W},j}$ denote the fraction of the demand for grade j requested from the LFSS silos and the warehouse, respectively, we have

$$SS_{\min j} = p_{\text{LFSS},j} I_{\min,j}, j \in \{\text{WG}, \text{SD}, \text{FH}\}$$

$$R_{\min j} = p_{\text{W},j} I_{\min,j}, j \in \{\text{WG}, \text{SD}, \text{FH}\}$$

where

$$p_{\text{LFSS},j} = (E_t[dST_{jt}] + E_t[dBC_{jt}])/E[d_j], j \in \{\text{WG}, \text{SD}, \text{FH}\}$$

$$p_{\text{W},j} = E_t[dBB_{jt}]/E[d_j], j \in \{\text{WG}, \text{SD}, \text{FH}\}$$

The results of the above computations are shown in Table 2-5.

Table 2-5. Fraction of the demand requested from the LFSS silos and the warehouse, and safety stock level in the LFSS silos and the warehouse, for each grade j

Grade j	WG	SD	FH
$p_{\text{LFSS},j}$	0.6882	0	0.4958
$p_{\text{W},j}$	0.3118	1	0.5042
$SS_{\min j}$	463.05	0	414.35
$R_{\min j}$	209.78	884.17	421.34

The safety stock levels that we used in the numerical example were set approximately equal (with some rounding) to the values shown in Table 2-5. More specifically, the exact values of the safety stock levels that we used are shown in Table 2-6.

Table 2-6. Safety stocks at the LFSS and the warehouse, and initial quantities in the warehouse

Grade j	1	2	3	4
Safety stock $SS_{min j}$	450	0	0	450
Safety stock $R_{min j}$	250	880	0	450

2.3.2 Numerical results

The results of the 24 sequential runs of the MILP solution are shown in Figures 2-3 to 2-6. More specifically, Figure 2-3 shows the trajectory of the final grade produced in each period. Throughout the entire 6-month period, there were 45 grade changeovers (20 color and 25 IV changeovers), which amounts to approximately 1.875 changeovers per week. As seen from Table 2-2, the mean demand for SD was relatively low, accounting for approximately 23 percent of the total mean demand. For this reason, most of the changeovers were between WG and FH, producing some SD and G along the way.

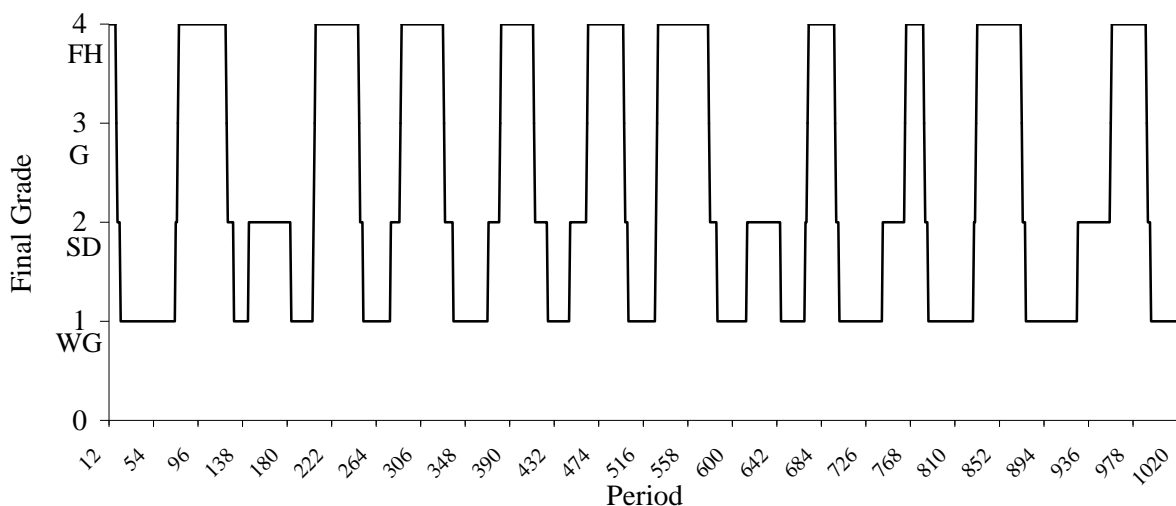

Figure 2-3. Evolution of the final grade produced in each period

Figures 2-4, 2-5 and 2-6 show the evolution of the inventory levels in the LFSS silos and the warehouse at the end of each week. From Figures 4 and 5, it can be seen that the LFSS silos were used as dedicated storage buffers throughout the entire 6-month period. More specifically, three silos (1, 3 and 5) contained WG throughout the entire 6-month period, three silos (4, 6 and 7) contained FH, one silo (8) contained SD, and one silo (2) contained G. In all but one week (week 5), grade G was emptied from silo 2 and filled in big bags which were then stored in the warehouse. There, its inventory kept increasing, because we had assumed that there is no demand for it, as was mentioned above. In fact, the amount of grade G produced was close to 4 tons per day on average ($= 20 \text{ color changeovers}/24 \text{ weeks} \times 1 \text{ period/changeover} \times 33.33 \text{ tons/period} \div 7 \text{ days/ week}$), which approximately covers the difference between average daily demand and production capacity.

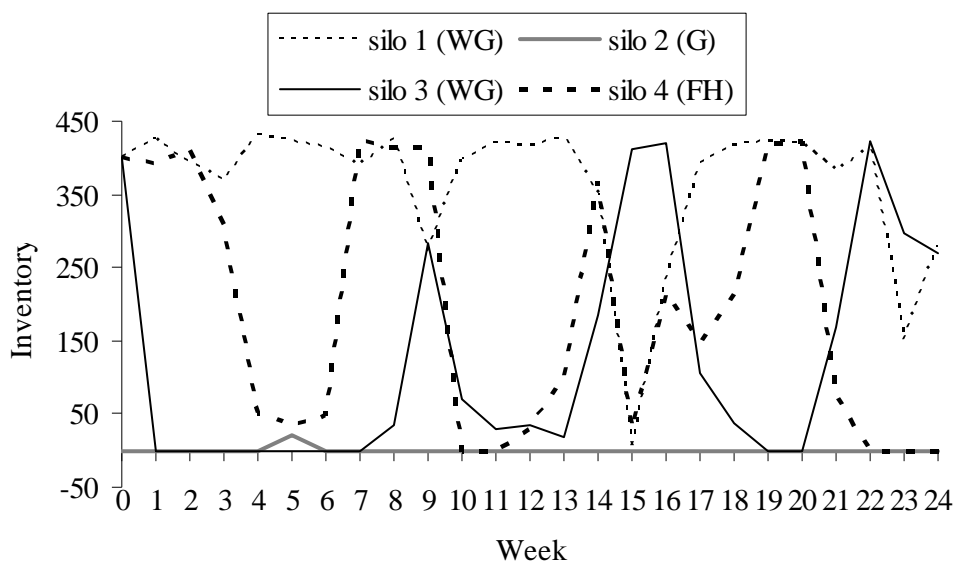

Figure 2-4. Evolution of inventory level in silos 1-4 of the LFSS at the end of each week

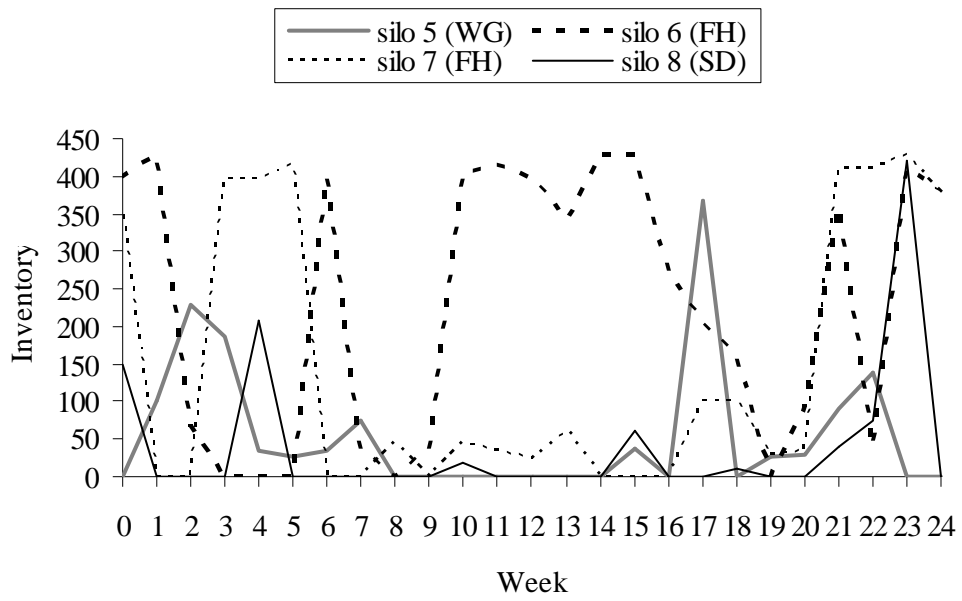

Figure 2-5. Evolution of inventory level in silos 5-8 of the LFSS at the end of each week

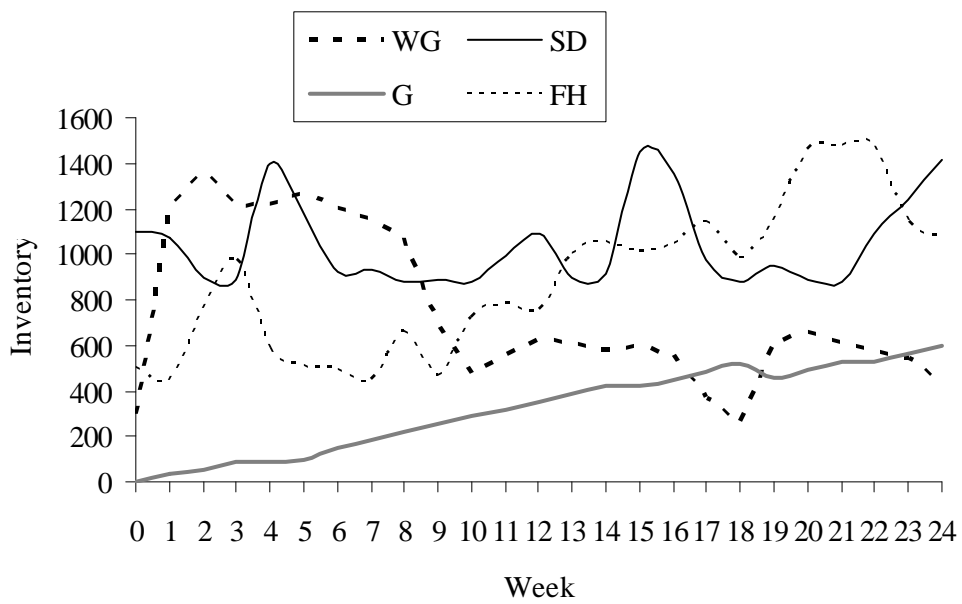

Figure 2-6. Evolution of inventory level in the warehouse at the end of each week

In Figures 2-4, 2-5 and 2-6, the inventory levels at the end of each week are connected with a straight line to help visualize their weekly evolution. The variation of the inventory levels from period to period within each week, however, was far from linear, at least for the LFSS silos. Figures 2-7, 2-8 and 2-9 show the evolution of inventory levels in the LFSS silos and the warehouse at the end of each period, during week 5 (periods 180-222). For example, from Figure 2-7, it can be seen that the inventory level of WG in silo 3 started and ended at zero in week 5, but went up to approximately 240 tons in the middle of that week. The inventory levels in the warehouse, however, were kept more or less stable during that week, as seen from Figure 2-8.

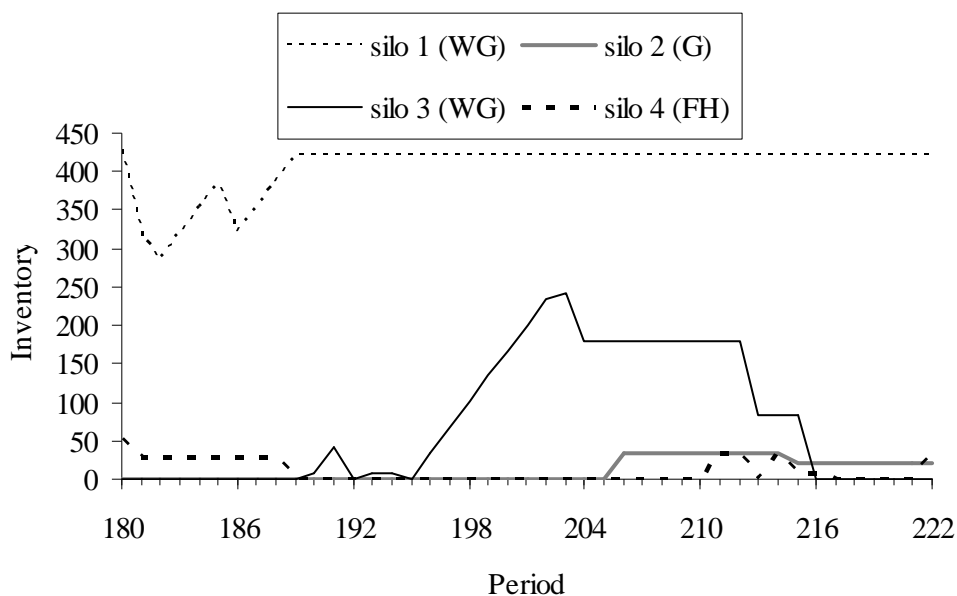

Figure 2-7. Evolution of inventory level in silos 1-4 of the LFSS at the end of each period in week 5

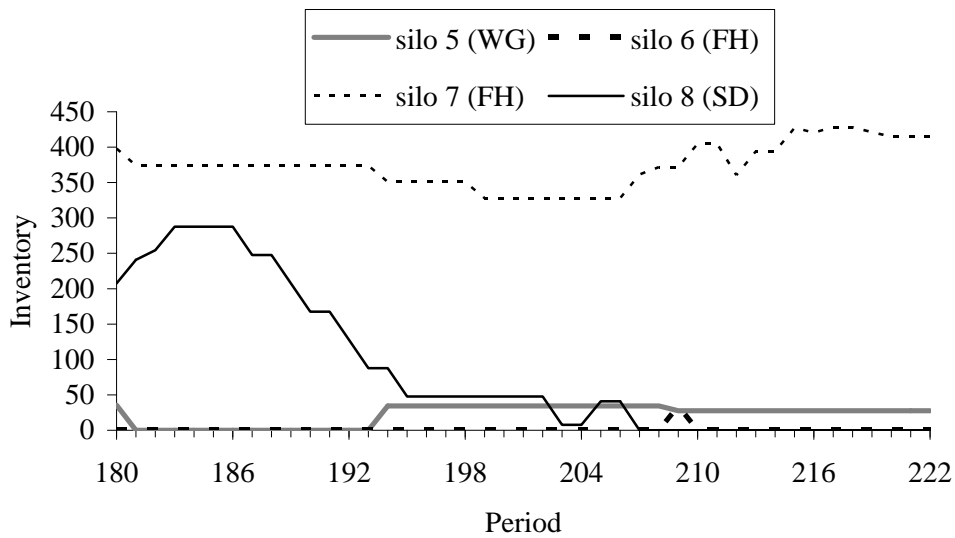

Figure 2-8. Evolution of inventory level in silos 5-8 of the LFSS at the end of each period in week 5

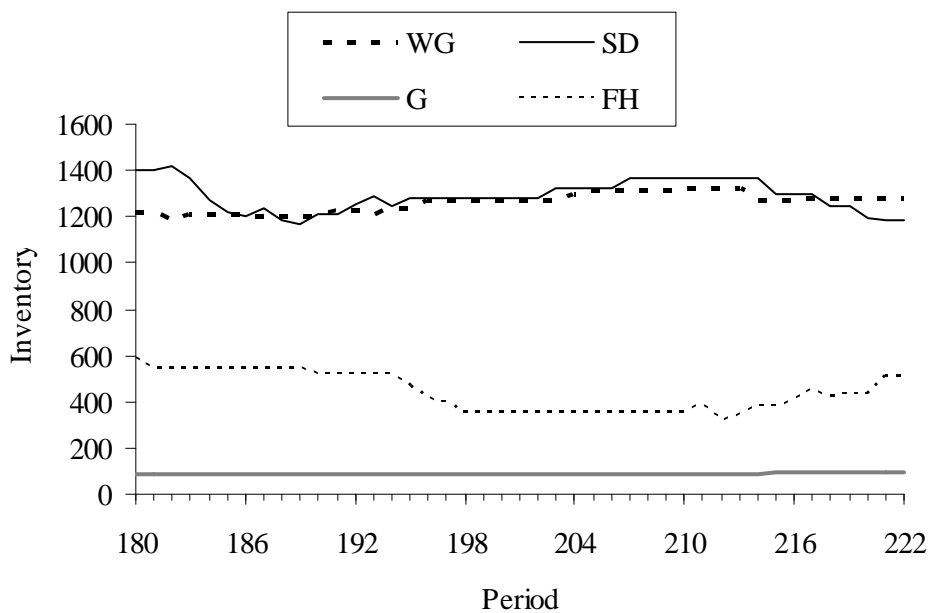

Figure 2-9. Evolution of inventory level in the warehouse at the end of each period in week 5

For the completeness of presentation, Figure 2-10 shows the demands per grade and type for each period of week 5. Also, Figure 2-11 shows in detail the optimal color setting at POLY, the

optimal IV setting at SSP, and the final grade coming out of SSP, based on the optimal color and IV combination, in each period of week 5. From Figure 2-11, note that during the changeover transition from high to low IV, which was initiated at the beginning of period 181 and lasted through period 186, the intermediate grade produced was divided into two halves, where the first half (periods 181-183) was characterized as SD and the second half (periods 184-186) as WG. Also note that the color changeover that was initiated at the beginning of period 194 resulted in the production of grade G in period 206, i.e., 12 periods later.

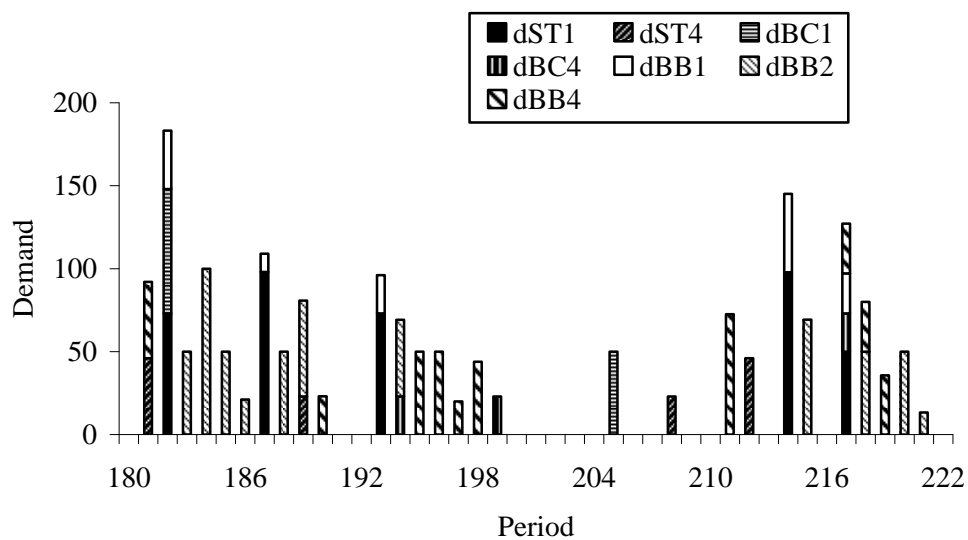

Figure 2-10. Scheduled demand per grade and type for each period in week 5

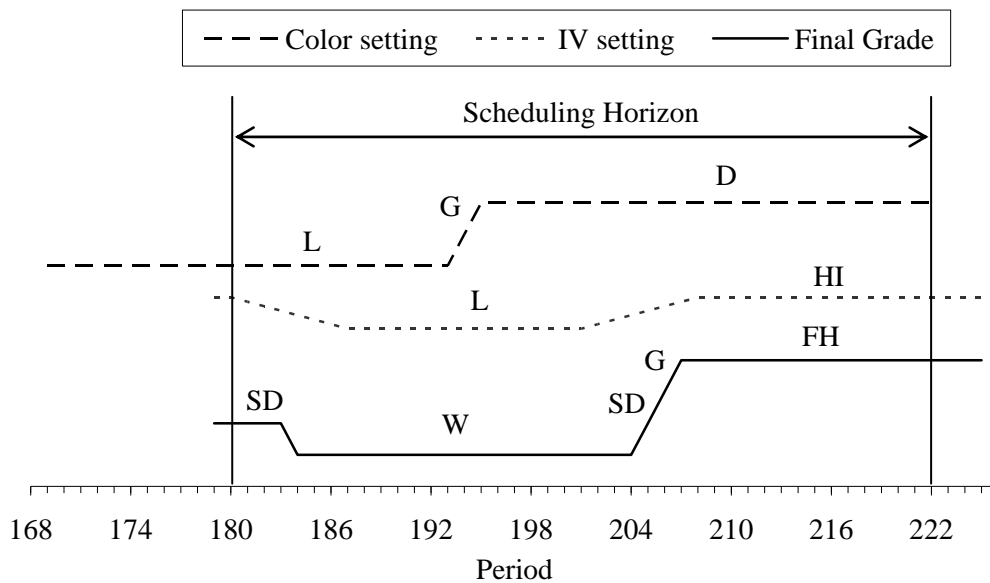

Figure 2-11. Color setting at POLY, IV setting at SSP and final grade produced in each period of week 5

2.3.3 Computational experience

In this section, we discuss some issues that are related to the computational effort to reach an optimal solution.

First, we need to determine the problem size of the MILP problem developed in Section 2.2. Table 2-7 shows the number of binary decision variables of the MILP problem, in general (column 2), and specifically for the problem instance presented in this section, where “ $|A|$ ” denotes the cardinality (number of elements) of a set A . Similarly, Table 2-8 shows the number of continuous decision variables. Finally, Table 2-9 shows the number of constraints included in constraint sets (2.2)-(2.35) in general (column 2), and specifically for the problem instance presented in this section.

Table 2-7. Number of binary decision variables

Binary variable	Number	Problem-instance specific number
x_{it}	$ I T$	$3 \cdot 54 = 162$
y_{jt}	$ J (T + F/2 - N - M)$	$4 \cdot 45 = 180$
α_t	$T - N - M + F - 1$	47
z_t	$T + F/2 - N - M + 1$	46
W_{qjt}	$ Q J (T - N - M + 1)$	$8 \cdot 4 \cdot 43 = 1376$
g_{qjt}	$ Q J (T - N - M)$	$8 \cdot 4 \cdot 42 = 1344$
Total	$ I T + J (T + F/2 - N - M + Q)$ $+ 2(T - N - M + 3F/4) + 2 Q J (T - N - M)$	3155

Table 2-8. Number of continuous decision variables

Binary Variable	Number	Problem-instance specific number
S_{qjt}	$ Q J (T - N - M + 1)$	$8 \cdot 4 \cdot 43 = 1376$
G_{qjt}	$ Q J (T - N - M)$	$8 \cdot 4 \cdot 42 = 1344$
b_{qjt}	$ Q J (T - N - M)$	$8 \cdot 4 \cdot 42 = 1344$
f_{qjt}	$Q J (T - N - M)$	$8 \cdot 4 \cdot 42 = 1344$
h_{qjt}	$Q J (T - N - M)$	$8 \cdot 4 \cdot 42 = 1344$
R_{jt}	$ J (T - N - M + 1)$	$4 \cdot 43 = 172$
Total	$5 Q J (T - N - M)$ $+ J (Q + T - N - M + 1)$	6924

The results for the 24 runs of the MILP problem presented in Section 2.3.2 were obtained in 17.5 seconds per run on average, with a standard deviation of 10.4 seconds, on a Pentium IV/1.8 GHz dual core processor with 1 GB system memory, using AMPL/CPLEX (see Fourer et al., 2002) version 9.1, with default values as the optimization software. The AMPL codes for the MILP problem under consideration is shown in Appendix C. The variation of the run times was quite significant, and the minimum and maximum computation times were 4.1 and 40.1 seconds, respectively, suggesting that the actual values of the problem parameters have a strong influence on the total computational effort. The complete set of the optimal cost (number of changeovers) and CPU times for each of the 24 runs is shown in Table 2-10.

Table 2-9. Number of constraints

Constraint set	Number	Problem-instance specific number
(2.2)	T	54
(2.3)	$2[(T - B - 1)B + (B + 1)/2]$	$2 \cdot 53 = 106$
(2.4)	$2(T + F/2 - N - M - 1)$	$2 \cdot 44 = 88$
(2.7), (2.8), (2.9), (2.10), (2.11)	$11(T + F/2 - N - M)$	$11 \cdot 45 = 495$
(2.5), (2.6), (2.14), (2.26), (2.28)	$5(T - N - M)$	$5 \cdot 42 = 210$
(2.12), (2.16), (2.17), (2.18), (2.19), (2.20), (2.22), (2.23)	$8 Q J (T - N - M)$	$8 \cdot 8 \cdot 4 \cdot 42 = 10752$
(2.15)	$ Q (T - N - M)$	$8 \cdot 42 = 336$
(2.21), (2.29), (2.35)	$3 J $	$3 \cdot 4 = 12$
(2.13), (2.24), (2.25), (2.27)	$4 J (T - N - M)$	$4 \cdot 4 \cdot 42 = 672$
(2.30)	$ I (N + M)$	$3 \cdot 12 = 36$
(2.32)	$(F - 1)$	5
(2.33), (2.34)	$2 Q J $	$2 \cdot 8 \cdot 4 = 64$
(2.31)	1	1
Total	$(T - N - M)(18 + 4 J + Q + 8 Q J) + 3T + 15(F/2) + J (3 + 2 Q) + I (N + M) + (B + 1)(1 - 2B) - 2$	12831

The last two columns of Table 2-10 show the optimal cost and CPU times of the Linear Programming (LP) relaxation of the original MILP problem. As is expected, the quality of the solution of the relaxed problem is better than that of the original MILP problem, because any MILP solution would also be a valid LP solution. More specifically, the optimal cost of the relaxed program is on average 25% of the cost of the original program, whereas the computational time of the relaxed problem is on average 36% of the computational time of the original problem. In all cases, the optimal cost of the LP problem is less than 1. Since the MILP problem has solution values that are integers (the numbers of changeovers), the optimal solution of the MILP problem must be at least as large as the next larger integer, namely, 1. In the 5 out of the 24 cases, the optimal MILP cost is 1; however, in 17 cases it is 2, and in 3 cases it is 3. This suggests that most cases, the LP relaxation does not provide a very tight lower bound on the solution quality of the original MILP problem.

Table 2-10. Optimal cost (number of changeovers) and CPU time for each of the 24 runs of the numerical example presented in Section 2.3

Run	Original MILP problem		LP relaxation of original MILP problem	
	Optimal cost	CPU (sec)	Optimal cost	CPU (sec)
1	1	35.47	0.033	2.57
2	2	29.76	0.174	3.65
3	2	7.51	0.235	1.65
4	1	20.99	0.389	2.41
5	3	20.02	0.804	3.62
6	2	6.80	0.482	1.81
7	2	33.10	0.741	5.68
8	2	20.50	0.607	1.47
9	2	30.74	0.526	8.635
10	2	19.95	0.625	5.35
11	2	16.34	0.529	5.77
12	2	5.30	0.337	2.87
13	2	7.71	0.464	5.47
14	2	12.76	0.467	4.74
15	1	16.81	0.261	11.01
16	3	17.47	0.544	4.84
17	2	5.41	0.518	2.87
18	2	40	0.688	12.37
19	2	4.07	0.581	2.58
20	2	13.93	0.194	8.32
21	2	5.30	0.478	4.06
22	1	26.26	0.059	5.29
23	1	16	0.489	5.84
24	2	8.08	0.694	4.47

An increase in the problem size is generally expected to increase the total computational effort. To explore the effect of problem size on the computational time, we solved several instances of the model, where in each instance we set the initial state of the system equal to the state of the system at the end of week 4, and gradually increased the scheduling horizon by one day (6 periods), starting with a horizon of 7 days (42 periods) and ending with a horizon of 14 days (84 periods). In other words, we solved the scheduling problem of week 5, then week 5 plus the first day of week 6,

then week 5 plus the first two days of week 6, and so on. The scheduling horizon of the last problem instance was exactly two weeks, corresponding to weeks 5 and 6.

The results are shown in Table 2-11. As can be seen from that table, the computational time increases significantly with the size of the problem, although not in all cases, which reveals that the size of the problem alone is not indicative of the computational effort needed to reach an optimal solution; the actual values of the problem parameters have a strong influence on the total computational effort too, as was mentioned above. An interesting observation from Table 2-11 is that the objective function (number of changeovers) remains at 3 for all instances. This means that 3 changeovers are optimal, whether we schedule production for week 5 alone or for weeks 5 and 6 together, assuming that we know the demands for both weeks. Note that in the original solution shown in Figure 2-3, where we sequentially solved the MILP problem for each week, the optimal number of changeovers for weeks 5 and 6 (periods 180-221 and 222-263) was 3 and 2, respectively, yielding a total of 5 changeovers.

Table 2-11. Effect of increasing the length of the scheduling horizon

Scheduling Horizon (periods)	Time (secs)	Objective Function
42	17.74	3
48	50.62	3
54	55.14	3
60	41.37	3
66	81.13	3
72	62.49	3
78	154.23	3
84	161.55	3

The example discussed in the previous paragraph reveals the potential benefits from extending the scheduling horizon for which demand information is available. To further explore these benefits, we solved 100 instances of our model, where in each instance we set the initial state

of the system equal to the state of the system at the end of week 4, the scheduling horizon equal to 2 weeks, and the demand in the first week equal to the demand in week 5. In each instance, the demand in week 6 was randomly generated from a distribution which we constructed based on the demands over the 6-month period for which we had data. One of the things we wanted to examine by running this experiment was the sensitivity of the cost (number of changeovers) in the first week with respect to the demand realizations in the second week, when we choose to solve the scheduling problem for weeks 5 and 6 as a single 2-week problem instead of two 1-week problems. We also wanted to see how the solution of the 2-week problem compared to the sum of the solutions of the two sequential 1-week problems.

The results are presented in Appendix B. They suggest that if demand data is available for two weeks instead of one week ahead of time, the chemical plant can be scheduled much more efficiently, i.e. with significantly fewer changeovers. This is because when the demand of the second week is known in advance, the scheduling procedure has the opportunity to merge the production of different quantities of the same grade, if possible, so as to decrease the total number of needed changeovers. As is expected, solving the single 2-week problem requires a longer computational time generally than solving the two 1-week problems. However, there exist some instances in which the required computational time for solving the scheduling problem of the second week as a single 1-week scheduling problem is longer than the required computational time for solving the respective 2-week problem. This is attributed to the fact that the required computational time strongly depends on the relevant position of initial final grades inventories and the emerging demand, because in case of a “tighter” respective situation, the optimization procedure has to search the optimal solution in a more rough solution space.

2.4 Conclusions

We developed an MILP model for the production scheduling of a multi-grade PET processing chemical plant. We also presented an application of the model on a real case study, along with some discussion that provides insight into its behavior. The model minimizes the cost associated with the number of grade changeovers, while also ensuring that the capacity constraints of the problem are not violated and that the demand for final products is satisfied on time. The model incorporates all aspects of the problem under consideration and can be easily extended to address additional ones that may arise in different situations, because of the large number of decision variables that enhances its flexibility. We believe that the main contribution of this work is that it addresses efficiently an important practical application, whose solution exhibits high complexity.

Chapter 3 The stochastic economic lot sizing problem for continuous nonstop multi-grade production

In this chapter, we study a variant of the Stochastic Economic Lot Scheduling problem (SELSP) in which a single production facility must produce several different grades of a family of products to meet random stationary demand for each grade from a common Finished-Goods (FG) inventory buffer with limited storage capacity. Demand that can not be satisfied directly from inventory is lost. Raw material is always available, and the production facility produces continuously at a constant rate. When the facility is set up to produce a particular grade, the only allowable changeovers are from that grade to the next lower or higher grade. All changeover times are constant and equal to each other. There is a changeover cost per changeover occasion, a spill-over cost per unit of product in excess whenever there is not enough space in the FG buffer to store the produced grade, and a lost-sales cost per unit short whenever there is not enough FG inventory to satisfy the demand. We model the SELSP as a discrete-time Markov Decision Process (MDP), where in each time period the decision is whether to initiate a changeover to a neighboring grade or keep the set up of the production facility unchanged, based on the current state of the system which is defined by the current set up of the facility and the FG inventory levels of all the grades. The goal

is to minimize the (long-run) expected average cost per period. For 2- and 3-grade problems, we numerically solve the exact MDP problem using the value iteration method. For problems with more than three grades, we develop a heuristic solution procedure which is based on approximating the original multi-grade problem with several 3-grade sub-problems and numerically solving each sub-problem using value iteration. We present numerical results for problem examples with 2-5 grades. For the 2- and 3-grade examples, we use the exact solution procedure to obtain insights into the structure of the optimal changeover policy. For the 4- and 5-grade examples, we compare the performance of the heuristic solution procedure against that of the exact procedure.

3.1 Introduction

Scheduling production of multiple products, each with random demand, on a single facility with limited production capacity and significant changeover costs and times between products is a classic problem in production planning research that is often referred to as the Stochastic Lot Scheduling Problem (SLSP). Sox et al. (1999) distinguish between two versions of the SLSP, for consistency with the deterministic-demand literature: the Stochastic Capacitated Lot Sizing Problem (SCLSP) and the Stochastic Economic Lot Sizing Problem (SELSP). The SCLSP assumes a finite planning horizon and allows for non-stationary demand, while the SELSP assumes an infinite planning horizon and stationary demand. The SCLSP is more appropriate for discrete-parts manufacturing, whereas the SELSP is perhaps better suited for continuous-processing manufacturing. Discrete-parts manufacturing is characterized by individual parts that are clearly distinguishable, and is often encountered in the industries of computer and electronic products, electrical equipment and appliances, transport equipment, machinery, fabricated metal, wood, furniture products, etc. Process industries, on the other hand, operate on material that is continuously flowing, as is the case with petroleum and coal products, metallurgical products,

nonmetallic mineral products, basic chemicals, food and beverage products, paper products, etc. Generally, process industries are capital intensive and focus on high-volume, low-variety production. In a typical process industry, the production facility produces continuously, at a constant rate, and the different products are really variants of the same family that differ in one or more attributes, such as quality, color, consistency, weight, size, thickness, etc. These variants are frequently referred to as “grades”. Often, the different grades are related in such a way that the only allowable changeovers are from one grade to the next higher or lower grade in the chain. For example, if the facility produces three grades, A, B, and C (A being the lowest and C being the highest), the allowable changeovers are between A and B, between B and C, but not directly between A and C. To indicate this ordering in the chain of allowable changeovers, we use the notation “A-B-C”. Avoiding grade changeovers is often of primary managerial concern, because during a changeover transition, the process is difficult to control, and the grade produced is off-specifications.

The deterministic version of the SELSP, the so-called ELSP, has received considerable attention in the literature over the past decades (e.g., see the surveys of Elmaghraby, 1978 and Salomon, 1991). Both analytical and heuristic solutions for the ELSP derive rigid cyclic production plans, which in many multi-grade plants take the form of rigid product *slates* or *wheels*, whereby all grades are produced sequentially in a cycle, starting from the lowest grade, going up all the way to the highest grade, and returning down to the lowest grade. In the previous example with the three grades, a complete grade slate would be $A \rightarrow B \rightarrow C \rightarrow B \rightarrow A$. Interestingly, clearing policies, i.e., policies where the facility switches to the product whose inventory level reaches zero first, may lead to inventory trajectories that exhibit chaotic behavior, i.e., that are sensitive to initial conditions, are non-periodic, etc., as Chase et al. (1993) show, even for a 3-product system with no changeover times and no constraints on the order of allowable changeovers.

Unfortunately, cyclic plans do not work well for the stochastic problem, for two reasons. Firstly, they focus on lot-sizing and not on dynamic capacity allocation, which is necessary to respond to random changes in demand. Secondly, in the stochastic problem, *finished-goods* (FG) inventories serve not only to reduce the number of changeovers, as is the case in the deterministic problem, but also to hedge against stock-outs. In the stochastic problem, both lot-sizing and capacity allocation have to be considered simultaneously, and the dynamics have to be included in the plan (Graves, 1980).

In this chapter, we study a variant of the SELSP in which a single production facility must produce several grades to meet random stationary demand for each grade from a common FG inventory buffer with limited storage capacity. Demand that can not be satisfied directly from stock is lost. Raw material is always available, and the production facility produces at a constant rate all the time. When the facility is set up to produce a particular grade, the only allowable changeovers are from that grade to the next lower or higher grade. In many industries, it is customary to divide the intermediate grade produced during a changeover, say from grade A to grade B, into two halves, and classify the first half as A and the second half as B, although in reality the grade of the product coming out of the production facility during the changeover transition is *gradually* changing from A to B. In this chapter, for simplicity, we assume that the grade produced during a changeover from A to B is classified as A, and that the grade produced during the reverse changeover is classified as B. Under this assumption, the amounts of grades A and B that will be produced in the long run will be the same as those that would have been produced had we divided the produced grade during a changeover into two halves. We also assume that all changeover times are deterministic and equal to each other.

The cost structure of our model includes a changeover cost per changeover occasion, a spill-over cost per unit of product in excess whenever there is not enough space in the FG buffer to store

the produced grade, and a lost-sales cost per unit short whenever there is not enough FG inventory to satisfy the demand. The assumptions presented above are realistic and are based on a real application of dynamic scheduling in a PET processing plant, presented in Chapter 2.

We model the SELSP problem described above as a discrete-time Markov Decision Process (MDP), where in each time period the decision is whether to initiate a changeover to a neighboring grade or keep the setup of the facility unchanged, based on the current state of the system, which is determined by the current setup and the FG inventory levels of all the grades. The goal is to minimize the (long-run) expected average cost per period.

For 2- and 3-grade problems we are able to numerically solve the resulting MDP problem using the value iteration method, and obtain insight into the optimal control policy. We refer to this solution procedure as “exact”, because it solves the exact problem. For problems with N grades, $N > 3$, we develop a heuristic solution procedure that is based on approximating the original N -grade problem by $(N - 2)$ 3-grade sub-problems and numerically solving each sub-problem using value iteration. Each 3-grade sub-problem is an approximation of the original N -grade problem, where the middle grade in the sub-problem corresponds to one of the grades in the original problem, the low (left) grade in the sub-problem is the composite of all grades in the original problem that are lower than the middle grade, and the high (right) grade is the composite of all grades that are higher than the middle grade. For example, if the original problem consists of five grades, A-B-C-D-E, we formulate the following 3-grade sub-problems: A-B-(C+D+E), (A+B)-C-(D+E), and (A+B+C)-D-E, where the notation “(A+B)” indicates the composite grade formed by grades A and B. After solving all the sub-problems, the heuristic control policy for the original N -grade problem is obtained by combining parts of the optimal policies of the sub-problems.

The rest of this chapter is organized as follows. In Section 3.2, we present the stochastic dynamic programming formulation of the MDP model of the original N -grade problem, and we

outline the successive approximation method to solve it. The heuristic procedure for solving problems with more than three grades is presented in Section 3.3. In Section 3.4, we present numerical results for problem examples with 2-5 grades. For the 2- and 3-grade examples, we use the exact solution procedure to obtain insights into the structure of the optimal changeover policy. For the 4- and 5-grade examples, we compare the performance of the heuristic solution procedure against that of the exact procedure. Finally, we draw our conclusions in Section 3.5.

3.2 Problem formulation and dynamic programming solution

We consider a discrete-time model of a production facility that can produce N different grades, one at a time. Grade changeovers are only allowed between neighboring grades, n and $n + 1$, $n = 1, \dots, N - 1$. The changeover time is one period. In each time period, the production facility produces P units of the grade that it is set up for at the beginning of the period. The quantity produced is stored in a common FG inventory buffer which has a finite storage capacity of X units; any excess amount that does not fit in the buffer is spilled over, incurring a spill-over cost of CS dollars per unit of excess product. The FG buffer is flexible in that it can contain any quantity of any grade at the same time, as long as the total amount does not exceed X . After the quantity produced by the facility has been added to the FG buffer, a vector of random demands, $\mathbf{D} \equiv (D_1, \dots, D_N)$, must be met from FG inventory, where D_n , $n = 1, \dots, N$, is the demand for grade n . The demands D_n are discrete random variables with known stationary joint probability distribution. For each grade n , the part of the demand that can not be satisfied from FG inventory, if any, is lost, incurring a lost-sales cost of CL_n dollars per unit of unsatisfied demand. In many real problems, especially in the process industries, changing P may cause instabilities in the production process; therefore, P is not considered to be a control variable for scheduling purposes, but is finely re-tuned once in a while so as to match the total expected demand for all grades, in case the demand has seasonal or other long-term variations.

For the purposes of short- to medium-term scheduling that we consider in this chapter, we assume that P is fixed and equal to the total expected demand for all grades.

We formulate the dynamic scheduling problem of the production facility as a discrete-time MDP, where the state of the system at the beginning of each period is defined by the vector $\mathbf{y} \equiv (s, x_1, \dots, x_N)$, where s is the grade that the facility is set up for during that period (called the “setup” state) and $x_n, n = 1, \dots, N$, is the FG inventory level of grade n at the beginning of the period. Note that $s \in \{1, \dots, N\}$, and the set of allowable inventory levels is determined by all integers $x_n, n = 1, \dots, N$, such that $0 \leq \sum_n x_n \leq X$. It is easy to see that the size of the state space is $(N \cdot X^N)/2$.

The decision, u , to be made at the beginning of each period is whether to initiate a changeover to a neighboring grade or leave the facility setup unchanged. Thus, if the current setup is s , the allowable decisions are given by the set $U(s)$, where $U(1) = \{1, 2\}$, $U(s) = \{s - 1, s, s + 1\}$, $s = 2, \dots, N - 1$, and $U(N) = \{N - 1, N\}$. If the decision is to initiate a changeover, then the new setup of the facility, i.e., after the changeover is completed, will be in effect at the beginning of the next period, since the changeover time is one period. A decision to initiate a changeover at the beginning of a period incurs a changeover cost of CC dollars in that period.

Suppose that the state of the system at the beginning of a period is \mathbf{y} , decision u is taken, and demand \mathbf{D} is realized. Let $g(\mathbf{y}, u, \mathbf{D})$ be the cost incurred during that period and let $\mathbf{y}' \equiv (s', x_1', \dots, x_N') = f(\mathbf{y}, u, \mathbf{D})$ be the state of the system at the beginning of the next period. From the above discussion, it is clear that

$$s' = u$$

$$x_n' = (x_n + p(\mathbf{y}) \cdot I_{n=s} - D_n)^+, n = 1, \dots, N$$

where $p(\mathbf{y})$ is the amount added to the FG buffer after the facility produces P units and before the demand is satisfied and is given by $p(\mathbf{y}) \equiv \min(P, X - \sum_n x_n)$, I_a is the indicator function which takes the value of 1 if a is true, and 0 otherwise, and $(x)^+ \equiv \max(0, x)$. Moreover,

$$g(\mathbf{y}, u, \mathbf{D}) = CC \cdot I_{u \neq s} + CS \cdot (P - p(\mathbf{y})) + \sum_n CL_n \cdot (D_n - x_n - p(\mathbf{y}) \cdot I_{n=s})^+$$

The objective is to find a state dependent policy, $u = \mu(\mathbf{y})$, that minimizes the (long-run) expected average cost per period. To find such a policy, we need to solve Bellman's dynamic programming equation, which for our problem can be written as

$$J + V(\mathbf{y}) = \min_{u \in U(s)} T_u(V(\mathbf{y})) \quad (3.1)$$

where J is the optimal (minimum) expected average cost per period, $V(\mathbf{y})$ is the optimal differential cost starting from state \mathbf{y} , and $T_u(\cdot)$ is a mapping defined as $T_u(V(\mathbf{y})) \equiv E_D\{g(\mathbf{y}, u, \mathbf{D}) + V(\mathbf{y}')\}$. The minimizer of the Bellman equation determines the optimal policy when the system is in state \mathbf{y} , denoted by $\mu^*(\mathbf{y})$.

To solve Bellman's equation, we use the method of successive approximations of the optimal differential cost functions, which is known as the value iteration method. We denote by $V_k(\mathbf{y})$ the value of the optimal differential cost function at the k th iteration. Initially, we set $V_0(\mathbf{y}) = 0, \forall \mathbf{y}$. The values at the $(k + 1)$ th iteration are obtained from the previous iteration by the recursion

$$V_{k+1}(\mathbf{y}) = T(V_k(\mathbf{y})) - T(V_k(\hat{\mathbf{y}})) \quad (3.2)$$

where $T(V_k(\mathbf{y})) = \min_{u \in U(s)} T_u(V_k(\mathbf{y}))$ and $\hat{\mathbf{y}}$ is an arbitrarily chosen special state. Note that in each iteration the optimal differential cost of the special state is reset to zero. Assuming that the iteration scheme converges to some values $V(\mathbf{y})$, then from recursion (3.2), these values must satisfy $T(V(\hat{\mathbf{y}})) + V(\mathbf{y}) = T(V(\mathbf{y}))$. A comparison of this equation and the Bellman equation (3.1) reveals that $J = T(V(\hat{\mathbf{y}}))$.

To implement the successive approximation method, at each iteration $k = 1, 2, \dots$ we compute the maximum and minimum differences, $V_k^U = \max_{\mathbf{y}}\{V_k(\mathbf{y}) - V_{k-1}(\mathbf{y})\}$ and $V_k^L = \min_{\mathbf{y}}\{V_k(\mathbf{y}) - V_{k-1}(\mathbf{y})\}$. The procedure is terminated when $|V_k^U - V_k^L| < \varepsilon \cdot T(V_k(\hat{\mathbf{y}}))$, where ε is some small positive scalar.

3.3 Heuristic solution procedure

Although the exact method presented in the preceding section can in principle determine the optimal policy for any number of grades, it becomes computationally intractable for more than three grades. In this section, we propose a heuristic procedure that approximates any N -grade problem, $N > 3$, by several 3-grade sub-problems and then uses the sub-problem solutions (determined by the exact method) to construct a heuristic policy for the original problem.

The heuristic procedure that we propose works as follows. Let S denote the original N -grade problem. For each grade n , $n = 2, \dots, N - 1$, we formulate a 3-grade sub-problem, denoted by S_n , in which the middle grade is grade n , the low grade is the composite of all grades that are lower than n , i.e., grades $1, \dots, n - 1$, and the high grade is the composite of all grades that are higher than n , i.e., grades $n + 1, \dots, N$; hence S_n is an approximation of the original problem S . For each sub-problem S_n , we define the state of the system by the vector $\mathbf{y}_n = (s_n, w_n, x_n, z_n)$, where $s_n \in \{1, 2, 3\}$ and w_n and z_n are the inventory levels of the low and high composite grades, respectively, and are given by the sums: $w_n \equiv x_1 + \dots + x_{n-1}$ and $z_n \equiv x_{n+1} + \dots + x_N$. In each sub-problem S_n , the demand distribution of the middle grade is the same as the demand distribution of grade n in the original problem, the demand distribution of the low grade is the convolution of the demand distributions of grades $1, \dots, n - 1$ in the original problem, and the demand distribution of the high grade is the convolution of the demand distributions of grades $n + 1, \dots, N$ in the original problem.

We use the exact method presented in the previous section to obtain the optimal policy of sub-problem S_n , denoted by $\mu_n^*(\mathbf{y}_n)$. The heuristic policy for the original N -grade problem, denoted by $\mu^h(\mathbf{y})$, is then constructed by using parts of the optimal policies of the sub-problems, as follows:

$$\mu^h(1, x_1, \dots, x_N) = \mu_2^*(1, \hat{w}_2, x_2, \check{z}_2)$$

$$\mu^h(n, x_1, \dots, x_N) = \mu_n^*(2, \hat{w}_n, x_n, \check{z}_n) + n - 2, n = 2, \dots, N - 1$$

$$\mu^h(N, x_1, \dots, x_N) = \mu_{N-1}^*(3, \hat{w}_{N-1}, x_{N-1}, \check{z}_{N-1}) + N - 3$$

where \hat{w}_n and \check{z}_n are the “aggregate” inventory levels of the low and high composite grades, respectively, in sub-problem S_n , which represent in some aggregate way the total of their individual components through some function h , i.e., $\hat{w}_n = h(x_1, \dots, x_{n-1})$ and $\check{z}_n = h(x_{n+1}, \dots, x_n)$. The terms “ $n - 2$ ” and “ $N - 3$ ” on the right-hand side of two of the above expressions are correction terms that account for the fact that setup states 1, 2, and 3 in sub-problem S_n , $n = 2, \dots, N - 1$, correspond to setup states $n - 1$, n , and $n + 1$, respectively, in the original problem. Next, we discuss how to determine an appropriate form for function h .

First, note that $\hat{w}_2 = h(x_1)$, i.e., \hat{w}_2 is the aggregate inventory level of a single grade, namely grade 1; therefore, it is reasonable to simply set $h(x_1) \equiv x_1$ so that $\hat{w}_2 = h(x_1) = x_1$. Similarly, we set $h(x_N) \equiv x_N$, so that $\check{z}_{N-1} = h(x_N) = x_N$. Let us next focus on \hat{w}_n , $n > 2$, as \check{z}_n is obtained in exactly the same way.

An obvious choice for the aggregate inventory level of the composite of grades 1, \dots , $n - 1$ is to set it equal to the sum of the inventory levels of the individual grades, i.e., set $\hat{w}_n = w_n$. This is a reasonable choice, especially with respect to estimating potential spill-over costs, but fails to detect the situation where the sum w_n is high, implying that the composite grade has a low risk of stock-out, but one (or more) of its individual components, x_1, \dots, x_{n-1} , is (are) low, implying that the corresponding individual grade(s) has(ve) a high risk of stock-out, which may lead to significant lost-sales costs. We refer to this situation as the “imbalance problem,” because one or more of the individual inventory levels are much lower than the average.

To illustrate the imbalance problem, suppose that the facility is currently set up to produce grade 4, and that the inventory levels of grades 1-4 are $(x_1, x_2, x_3, x_4) = (15, 15, 0, 6)$. Then, in sub-problem S_4 , the inventory level of the middle grade would be $x_4 = 6$, and the total inventory level of the low composite grade would be $w_4 = x_1 + x_2 + x_3 = 30$. In this case, the optimal policy obtained

from solving S_4 might indicate that it is optimal for the facility not to change over to the low composite grade, because there is plenty of it (30 units) in storage compared to the inventory level of the middle grade 4, which is much lower (6 units). What the heuristic fails to see here is that although w_4 is relatively high, its individual components are quite imbalanced – in fact, one of them, namely x_3 , is zero. In this case, unless the facility changes over to grade 3, a heavy lost-sales cost is likely to be incurred in the current and in the following period.

To tackle the imbalance problem, we seek an aggregate inventory level, \hat{w}_n , for the composite of grades 1, ..., $n - 1$, that would somehow reflect the imbalance, if any, among the individual inventory levels x_1, \dots, x_{n-1} . A natural measure of the imbalance of the individual inventory levels is the sum of their expected lost sales, denoted by ILS_n , given by

$$ILS_n \equiv E[(D_1 - x_1)^+] + \dots + E[(D_{n-1} - x_{n-1})^+]$$

The expected lost sales for any given aggregate inventory level, w , of the composite grade, on the other hand, denoted by $CLS_n(w)$, is given by

$$CLS_n(w) \equiv E[(D_1 + \dots + D_{n-1} - w)^+]$$

With the above definitions in mind, in order to capture the imbalance, if any, among the individual inventory levels x_1, \dots, x_{n-1} , we propose the following expression for the aggregate inventory level, \hat{w}_n :

$$\hat{w}_n = \begin{cases} w_n, & \text{if } ILS_n = 0 \\ v_n, & \text{if } ILS_n > 0 \end{cases} \quad (3.3)$$

where $v_n \equiv w: CLS_n(w) = ILS_n$, i.e., v_n is that value of the aggregate inventory level which makes the expected lost sales of the composite grade equal to the sum of the expected lost sales of the individual grades.

To compute v_n we need to derive the probability distribution of the demand of the composite grade by convolving the probability distributions of the demands of the individual grades. In case

this is not computationally convenient, we propose a faster alternative in which we approximate ILS_n by the expression

$$ILS_n \approx (E[D_1] - x_1)^+ + \dots + (E[D_{n-1}] - x_{n-1})^+$$

This then allows us to compute v_n by the following expression:

$$v_n = E[D_1] + \dots + E[D_{n-1}] - ILS_n \quad (3.4)$$

Expression (3.3) prescribes that the aggregate inventory level, \hat{w}_n , be set equal to either w_n , if $ILS_n = 0$, or v_n , if $ILS_n > 0$. It can be easily shown that $v_n \leq w_n$. Given that v_n may be significantly smaller than w_n , where w_n is the natural candidate for the aggregate inventory level of the composite grade, we propose to use a “smoother”, more general rule than the one prescribed by expression (3.3). According to the more general rule, \hat{w}_n is set equal to a linear combination of w_n and v_n (rounded to the nearest integer), if $ILS_n > 0$, namely

$$\hat{w}_n = \begin{cases} w_n, & \text{if } ILS_n = 0 \\ \alpha v_n + (1 - \alpha)w_n, & \text{if } ILS_n > 0 \end{cases} \quad (3.5)$$

for some coefficient α , such that $0 \leq \alpha \leq 1$, where v_n is given by (3.4). Note that if $\alpha = 0$, the rule prescribed by (3.5) becomes $\hat{w}_n = w_n$, whereas if $\alpha = 1$, the rule becomes identical to that prescribed by expression (3.3). Clearly, the smaller the imbalance problem, the smaller the optimal value of α , and the better the performance of the heuristic. In Section 3.4.3, we investigate the performance of the heuristic as a function of coefficient α .

The heuristic policy that we described above, as any feedback policy, satisfies an expression similar to Bellman’s equation (3.1), without the minimization, i.e., it satisfies

$$J^h + V^h(\mathbf{y}) = T_{u^h}^h(V^h(\mathbf{y})) \quad (3.6)$$

where J^h is the expected average cost per period and $V^h(\mathbf{y})$ is the differential cost starting from state \mathbf{y} , when the heuristic policy $u^h = \mu^h(\mathbf{y})$ is used. Note that J^h , $V^h(\mathbf{y})$, and $\mu^h(\mathbf{y})$ also depend on α , but we omitted this dependence here for notational simplicity.

One way to evaluate the heuristic policy is to use the method of successive approximations of the differential cost functions $V^h(\mathbf{y})$. More specifically, if we denote by $V_k^h(\mathbf{y})$ the values of the differential cost function at the k^{th} iteration, then the values at the $(k + 1)^{\text{th}}$ iteration are obtained from the previous iteration by a recursion similar to (3.2), without the minimization, i.e.,

$$V_{k+1}^h(\mathbf{y}) = T_{u^h}(V_k^h(\mathbf{y})) - T_{u^h}(V_k^h(\hat{\mathbf{y}})) \quad (3.7)$$

Note that as in (3.2), at each step of iteration (3.7), the differential cost of the special state $\hat{\mathbf{y}}$ is reset to zero. Assuming that the iteration scheme converges to some values $V(\mathbf{y})$, for all \mathbf{y} , then the expected average cost per period of the heuristic policy is given by $J^h = T_{u^h}(V^h(\hat{\mathbf{y}}))$.

An alternative way to evaluate the heuristic policy is to use simulation. Our numerical experience for 4-grade and 5-grade problems showed that the simulation is faster than the method of successive approximations by as much as 100 times.

3.4 Numerical results

In this section, we present numerical results for problem examples with 2-5 grades. First, we solve a 2-grade example using the exact solution procedure. For that example, we discuss the optimal changeover policy, and we explore the effect of problem parameters on the optimal expected average cost per period and on the computational time of the successive approximation procedure. Then, we solve a 3-grade example originating from a real application presented in Chapter 2, for which we also discuss the optimal changeover policy. Finally, we solve 4-grade and 5-grade examples using both the exact and the heuristic solution procedures. We discuss the performance and computational efficiency of the heuristic procedure, and we explore how they are affected by the distribution of the relative market size of the different grades and the size of weight α in

expression (3.5). The programming codes for implementing the exact and heuristic solution procedures are shown in Appendix D.

3.4.1 2-grade example

First, we consider a 2-grade example ($N = 2$), where $P = 5$, and the demand distribution for the two grades is given in Table 3-1.

Table 3-1. Probability distribution of demand, $\Pr(D_n=i)$, for the 2-grade example

n	i							$E[D_n]$
	0	1	2	3	4	5	6	
1	0.1	0.15	0.15	0.2	0.15	0.15	0.1	3
2	0.15	0.15	0.4	0.15	0.15	0	0	2

We run the successive approximation procedure outlined in Section 3.2 for various combinations of storage capacity, X , and cost rate parameters, CC , CS , CL_1 and CL_2 . In each case, we assumed that both grades have the same lost-sales cost rate, i.e., $CL_1 = CL_2 = CL$. The results are shown in Table 3-2. Note that case 1 represents the situation where there is no changeover cost. For each case shown in Table 3-2, the results are spread in three rows. The first row shows the number of iterations of the successive approximation procedure until convergence, denoted by k_c , for convergence tolerance criterion $\varepsilon = 0.001$, the total CPU time in hours on an Intel Pentium PC at 2.99 GHz with 1 GB RAM, and the resulting optimal expected average cost per period, J . The second row shows the per period expected average number of changeovers, units spilled over, and lost sales for each grade, denoted by $E[C]$, $E[S]$, $E[L_1]$ and $E[L_2]$, respectively. These quantities are related to J by the expression

$$J = CC \cdot E[C] + CS \cdot E[S] + CL \cdot E[L_1] + CL \cdot E[L_2] \quad (3.8)$$

The third row includes the components of the inventory level vector that minimizes the optimal differential cost function $V(s, x_1, x_2)$, denoted by $(x_1^*(s), x_2^*(s))$, for $s = 1, 2$. This vector represents the optimal (or ideal) inventory level vector for setup state s , and is equivalent to the optimal hedging point in the manufacturing flow control literature (e.g., see Kimemia and Gershwin (1983)) or the optimal order-up-to level in classical inventory theory.

Table 3-2. Results for the 2-grade example

Case	CC	CS	CL	X = 40				X = 60				X = 80			
				k_c	CPU	J	-	k_c	CPU	J	-	k_c	CPU	J	-
				$E[C]$ $x_1^*(1)$	$E[S]$ $x_2^*(1)$	$E[L_1]$ $x_1^*(2)$	$E[L_2]$ $x_2^*(2)$	$E[C]$ $x_1^*(1)$	$E[S]$ $x_2^*(1)$	$E[L_1]$ $x_1^*(2)$	$E[L_2]$ $x_2^*(2)$	$E[C]$ $x_1^*(1)$	$E[S]$ $x_2^*(1)$	$E[L_1]$ $x_1^*(2)$	$E[L_2]$ $x_2^*(2)$
1	0	5	5	105	0.1693	0.7181	-	258	0.9027	0.4493	-	480	2.9438	0.3270	-
				0.6843	0.0550	0.0606	0.0281	0.6874	0.0340	0.0380	0.0178	0.6898	0.0246	0.0277	0.0130
				8	12	13	7	14	16	19	11	15	25	20	20
2	1	5	5	253	0.4045	0.9804	-	642	2.2917	0.6168	-	1210	7.5323	0.4494	-
				0.1991	0.0777	0.0412	0.0374	0.1285	0.0486	0.0248	0.0243	0.0943	0.0353	0.0180	0.0177
				1	21	22	0	2	32	34	0	2	44	46	0
3	10	1	1	448	0.7059	1.1433	-	489	1.7415	0.7522	-	502	3.1532	0.5592	-
				0.0772	0.1854	0.0774	0.1084	0.0530	0.1111	0.0442	0.0673	0.0399	0.0804	0.0318	0.0483
				0	31	31	0	0	48	48	0	0	65	65	0
4	2	5	5	240	0.3808	1.1616	-	599	2.0880	0.7327	-	1125	7.2427	0.5343	-
				0.1662	0.0825	0.0419	0.0415	0.1067	0.0517	0.0252	0.0270	0.0781	0.0377	0.0174	0.0206
				1	22	23	0	1	35	36	0	1	48	49	0
5	1	10	5	295	0.4660	1.3638	-	730	2.5438	0.8567	-	1361	8.6798	0.6241	-
				0.2258	0.0757	0.0397	0.0365	0.1434	0.0475	0.0260	0.0218	0.1047	0.0346	0.0170	0.0177
				1	15	16	0	1	24	25	0	2	32	34	0
6	1	5	10	323	0.5166	1.3652	-	807	2.8111	0.8570	-	1513	9.8512	0.6247	-
				0.2253	0.0758	0.0397	0.0364	0.1429	0.0476	0.0258	0.0219	0.1044	0.0346	0.0170	0.0177
				2	25	27	0	2	39	41	0	2	54	56	0
7	5	10	1	232	0.3676	1.6879	-	561	1.9624	1.0705	-	1037	6.6267	0.7823	-
				0.1330	0.0930	0.0440	0.0492	0.0869	0.0578	0.0275	0.0304	0.0641	0.0420	0.0184	0.0236
				0	12	12	0	0	19	19	0	0	27	27	0
8	5	1	10	262	0.4145	1.6897	-	640	2.2517	1.0717	-	1188	7.4947	0.7831	-
				0.1320	0.0934	0.0438	0.0498	0.0866	0.0580	0.0276	0.0305	0.0639	0.0421	0.0185	0.0236
				1	34	35	0	1	53	54	0	2	71	72	0
9	1	10	10	259	0.4121	1.7419	-	652	2.2822	1.0943	-	1227	7.7948	0.7969	-
				0.2426	0.0744	0.0391	0.0364	0.1546	0.0467	0.0257	0.0216	0.1116	0.0341	0.0176	0.0168
				1	20	21	0	2	31	33	0	2	42	44	0
10	10	5	10	213	0.3374	2.7081	-	521	1.8811	1.7239	-	965	5.9797	1.2617	-
				0.1203	0.1001	0.0451	0.0554	0.0790	0.0621	0.0290	0.0334	0.0582	0.0452	0.0197	0.0257
				1	29	30	0	1	45	46	0	1	62	63	0

From the results, it can be seen that the values of k_c and CPU range from 105 iterations in 0.1693 hours (~ 10 min), in case 1 ($X = 40$), to 1513 iterations in 9.8512 hours, in case 6 ($X = 80$). As X increases, k_c and CPU increase significantly, whereas $E[C]$, $E[S]$, $E[L_1]$, $E[L_2]$ and J decrease, as would be expected. Note that k_c and CPU are significantly lower in case 1 than in any other case, since $CC = 0$ in case 1. As would also be expected, J increases as the cost rate parameters increase. From the results, it can also be seen that as one of the cost rate parameters, say CS , increases, the respective quantity that it multiplies in the objective function (3.8), i.e., $E[C]$, decreases, but the overall optimal expected average cost per period, J , increases.

In all cases, except case 1, the optimal inventory level of the grade that the facility is set up for is close to or equal to zero, whereas the optimal inventory level of the other grade is quite significant. The reason for this is that when the facility is set up for a particular grade, say grade 1, ideally one would like to have low inventory of grade 1 and high inventory of grade 2, so that the facility can continue producing grade 1 for as many periods as possible without having to change over to grade 2 and pay the changeover cost. This is no longer true for case 1, where changeovers cost nothing.

Also, the optimal inventory levels seem to be more or less symmetric for the two grades, i.e., $x_1^*(1) \approx x_2^*(2)$ and $x_2^*(1) \approx x_1^*(2)$, except that the inventory level of grade 1 is slightly higher than that of grade 2, because grade 1 has higher expected demand than grade 2.

In addition, the optimal inventory level of the grade not being produced appears to be increasing with CL (e.g., compare cases 2 and 6) and decreasing with CS (e.g., compare cases 2 and 5). The reason for this is that the higher the cost rate of stock-outs, CL , the higher the optimal inventory level to better hedge against stock-out occurrences. Similarly, the higher the cost rate of

material spill-over, CS , the lower the optimal inventory level to better hedge against spill-over occurrences.

Finally, the optimal inventory level of the grade not being produced appears to be quite insensitive to CC (e.g., compare cases 2, 4 and 9, as well as cases 6 and 10). The reason for this is that the optimal inventory level vector primarily serves to hedge against stock-out and spill-over occurrences and is therefore affected by CL and CS , as was mentioned above. CC primarily affects the lot-size of each grade that should be produced in a single run, which in turn affects the cycle stock and changeover frequency. In other words it affects the width of the “changeover corridor”, which we will discuss in detail in the figures that follow.

Figure 3-1 shows the optimal changeover policy as a function of inventories x_1 and x_2 , for cases 2 and 4 of Table 3-2, for $X = 40$, and is representative of all other cases, except case 1, which will be discussed later. From Figure 3-1, it can be seen that in both cases, the optimal policy partitions the inventory space in several regions, where each region is characterized by a different optimal changeover action. The optimal changeover policy when the facility is set up to produce grade s and the inventory level vector (x_1, x_2) is in region R , denoted by $\mu^*(s, R)$, is shown in Table 3-3, where “changeover to grade 1” is understood to mean “changeover to grade 1 if the facility is set up for grade 2, otherwise remain set up for grade 1”.

Table 3-3. Optimal policy $\mu^*(s, R)$ for the 2-grade example

	s		
R	1	2	Description
a	1	1	Changeover to grade 1
b	1	2	Do not changeover
c	2	1	Changeover to the other grade
d	2	2	Changeover to grade 2

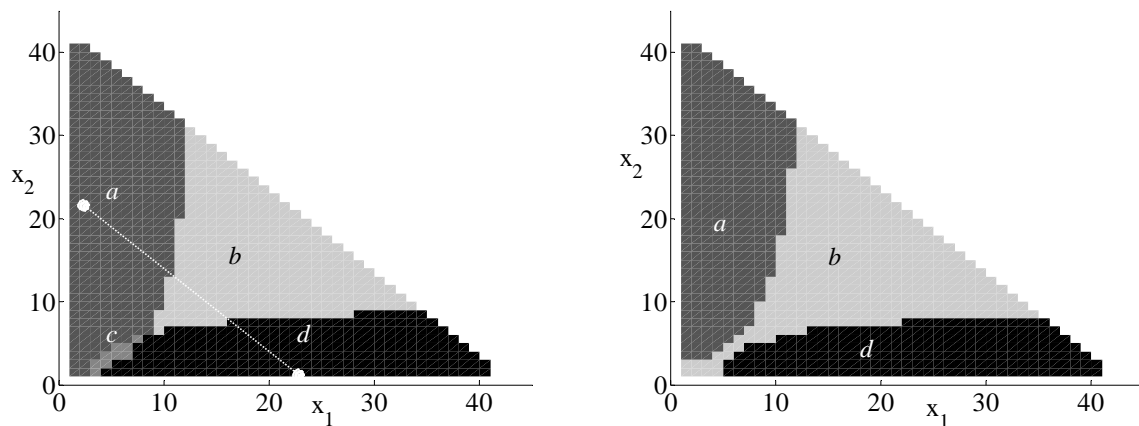

Figure 3-1. Optimal changeover policy for cases 2 (left) and 4 (right) of Table 3-2, for $X = 40$

If the inventory level vector is in region c , the facility changes over from one grade to the other in each period. This behavior is sometimes referred to as “chattering”. If the inventory level vector is in region b and the facility is set up for grade 1, then the facility will keep producing grade 1 in successive periods, until the inventory level vector crosses the border between regions b and d . At that point, the facility will change over to grade 2. The facility will then keep producing grade 2 in successive periods, until the inventory level vector crosses the border between regions b and a . At that point, it will change over to grade 1, and the cycle will be repeated. Note that region b is wider in case 4 than in case 2, indicating that in case 4, the facility produces longer runs (campaigns) of each grade with less frequent changeovers. This is because the changeover cost in case 4 is twice as big as in case 2. In fact, the widening of region b in case 4 is so big that it has caused region c to disappear. Also note that the inventory space partition is more or less symmetric for the two grades, with regions c and b forming a more or less diagonal corridor bounded by regions a and d . This corridor has a slight displacement in favor of grade 1, due to the fact that grade 1 has a higher expected demand than grade 2, and a slope which is approximately equal to the ratio $E[D_2]/E[D_1] = 2/3$. In addition, it is funnel-shaped, with its narrow end towards the origin and

its wide end towards the inventory state space outer facet, indicating that more frequent changeovers take place when the inventory levels of both grades are low and the risk of a stock-out is high, and less frequent changeovers take place when the inventory levels are high. The borders of the corridor towards its wider end tend to align themselves to the orthogonal lines $x_1 = c_1$ and $x_2 = c_2$, respectively, where c_1 and c_2 are some constants. This means that when the facility is set up for grade 2, it should change over to grade 1, if x_1 drops below c_1 , irrespectively of x_2 , as long as x_2 is high. Thus, the optimal changeover policy, which is generally “global” in that changeover decisions depend on both x_1 and x_2 , becomes “local” in one grade when the inventory level of the other grade is high.

Note that when $s = 1$, x_1 increases by 2 units and x_2 decreases by 2 units per period on average, while when $s = 2$, x_1 decreases by 3 units and x_2 increases by 3 units per period on average. This implies that on average, the inventory level vector tracks the line $x_1 + x_2 = X'$, for some $X' < X$. This line is parallel to the outer facet of the inventory state space, $x_1 + x_2 = X$. Under the optimal changeover policy, the line $x_1 + x_2 = X'$ should connect the optimal target inventory level points $(x_1^*(1), x_2^*(1))$ and $(x_1^*(2), x_2^*(2))$. This means that X' should satisfy: $x_1^*(1) + x_2^*(1) = X'$ and $x_1^*(2) + x_2^*(2) = X'$. Indeed, in all cases shown in Table 3-2, there exists a value of X' that satisfies the above two equations. For example, in case 2, $X = 40$, $x_1^*(1) + x_2^*(1) = 1 + 21$, $x_1^*(2) + x_2^*(2) = 22 + 0$, and therefore, $X' = 22$, suggesting that under the optimal changeover policy, the FG inventory buffer should be kept a little over half full. The line connecting the optimal target inventory levels of the two setup states for this case is shown as a dotted line in Figure 3-1 (left). Under the optimal changeover policy, the inventory level vector on average moves back and forth along the segment of that dotted line that falls in region b , as the facility changes over from one grade to the other, whenever the inventory level vector enters region a or d . Such a trajectory is on average parallel to the optimal inventory level trajectory of the deterministic version of the problem (where the demand

for each grade in each period is constant and equal to its expected value) which follows the line connecting the two corners of the inventory state space, $(X, 0)$ and $(0, X)$, because that trajectory minimizes the changeover frequency without incurring any lost-sales or spill-over cost.

Figure 3-2 shows the optimal changeover policy for cases 3 and 1 of Table 3-2, for $X = 80$. Note that the inventory space partition in case 3, shown in Figure 3-2 (left), is similar to that in case 4, shown in Figure 3-1 (right), except that region b is much wider. This is because in case 3, the changeover cost rate is much higher than the other cost rates, compared to case 4.

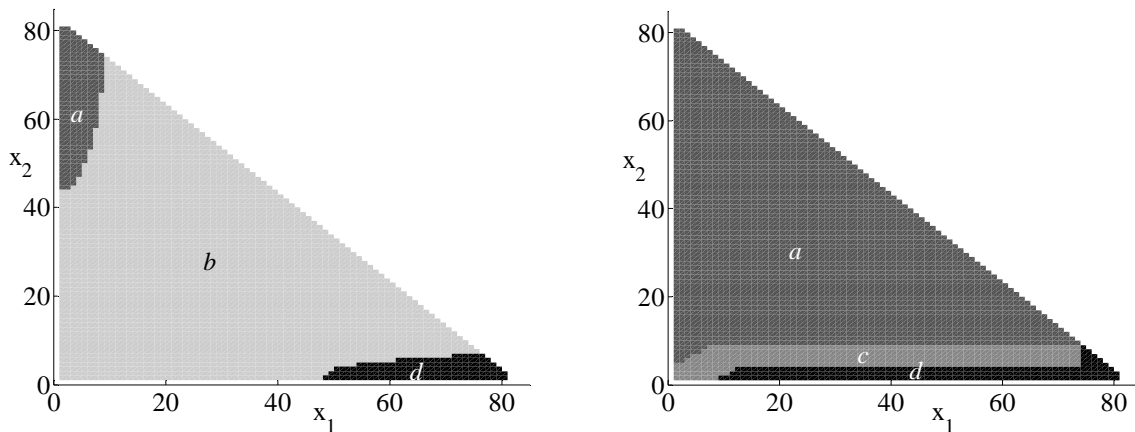

Figure 3-2. Optimal changeover policy for case 3 (left) and case 1 (right) of Table 3-2, for $X = 80$

The structure of the inventory space partition in case 1, shown in Figure 3-2 (right), is different than the partitions shown in the other figures. First, region b is absent, which means that the facility need not produce long campaigns of each grade with infrequent changeovers. This is because the changeover cost is zero. If the inventory level vector is in region c , the facility changes over from one grade to the other in each period, as in case 2, shown in Figure 3-1 (left). Also, as in case 2, the corridor defined by region c is diagonal for low inventory vector levels, with a slope which is approximately equal to ratio $E[D_2]/E[D_1] = 2/3$. The difference with case 2 and all the

other cases as well is that region c turns into a narrow constant-width corridor which is parallel to the x_1 -axis at the level of $x_2 = 5 \pm 2$, for values of x_1 larger than approximately 10. This means that unless the inventory level of grade 2 is extremely low, priority is always given to the production of grade 1. This can be explained as follows. As was mentioned earlier, when the facility is set up for grade 1, x_1 advances by 2 units and x_2 drops by 2 units per period on average, whereas when the facility is set up for grade 2, x_2 drops by 3 units and x_2 advances by 3 units per period on average. Given that there is no changeover or inventory holding cost, if the inventory level vector is not too low, the former state (i.e., the state where the facility is set up for grade 1) is preferable to the latter state, because on average it results in smaller jumps per period of the inventory level vector, and hence prolongs the time that the inventory level vector approaches the orthogonal boundaries of the triangular inventory state space, where the risk of incurring a lost-sales cost is high.

3.4.2 3-grade example

Next, we consider a 3-grade ($N = 3$) example that originated from a real dynamic scheduling application of a continuous-flow processing plant that produces three grades of Polyethylene Terephthalate (PET) resin, presented in Chapter 2. PET is the workhorse polyester used for making stretch-blown beverage bottles. The three grades differ from each other in the combination of two key properties: *Color* and *Intrinsic Viscosity (IV)*, as shown in Table 3-4. The chain of allowable changeovers is 1-2-3.

Table 3-4. Description of bottle-grade PET resin final products

Grade Name	Description	IV	color
1	Water Grade (WG) PET for water bottles	low	light
2	Soft Drink (SD) PET for carbonated soft-drink bottles	high	light
3	Fast Heat (FH) PET for dark-colored carbonated soft-drink bottles	high	dark

The plant produces 180 tons/day and has a FG storage capacity of 3440 tons. We discretize material and time so that each unit of material produced, stored, or demanded in each time period of the MDP equals 30 tons, and each time period equals 48 minutes. This makes $P = 6$ and $X = 115$. The distribution of the discretized demand for the three grades is given in Table 3-5. Note that the total expected demand rate is 6.0291 units per period, which is very close to the production rate P . The cost rate parameters that we used are $CC = 1$, $CS = CL_1 = CL_2 = 2$, to reflect the fact that the plant manager wishes to avoid frequent changeovers, but is even more wary about material spill-over and lost sales.

Table 3-5. Probability distribution of demand, $\Pr(D_n=i)$, for the 3-grade example

n	I										$E[D_n]$	
	0	1	2	3	4	5	6	7	8	9		10
1	0.1676	0.1429	0.3214	0.1538	0.1016	0.0604	0.0247	0.0110	0.0137	0.0027	0.0000	2.3159
2	0.5000	0.1648	0.1071	0.0824	0.0604	0.0302	0.0220	0.0137	0.0027	0.0110	0.0055	1.4231
3	0.1519	0.2652	0.2956	0.0718	0.0663	0.0525	0.0442	0.0138	0.0276	0.0028	0.0083	2.2901

We solved the problem optimally using the successive approximation method outlined in Section 3.2. The method converged after 533 iterations that took 269 hours on an Intel Pentium PC at 2.99 GHz with 1 GB RAM, for convergence tolerance criterion $\varepsilon = 0.01$. The resulting optimal expected average cost per period, J , is 0.4522. As in the 2-grade example, the optimal policy partitions the inventory space in several regions, each characterized by a different optimal changeover action. The optimal changeover policy $\mu^*(s, R)$ is given in Table 3-6.

Figures 3-3 and 3-4 show the optimal changeover policy as a function of inventory levels x_1 and x_3 , for given values of inventory level x_2 . More specifically, Figure 3-3 (left), shows the optimal changeover policy when $x_2 (= 90) \gg x_1 + x_3$. From that figure, it can be seen that if $(x_1, x_3) \in a$, in which case $x_2 \gg x_3 \gg x_1$, then the production facility must change over to the next lower grade so

that it is eventually set up for grade 1, because x_1 is significantly lower than x_2 and x_3 . If $(x_1, x_3) \in b$, in which case $x_2 \gg x_3 > x_1$, then the facility must change over to grade 1, if it is set up for grade 2. If it is set up for grade 3, however, it need not change over to grade 2 (to eventually change over to grade 1), because x_1 is not that much lower than x_3 to justify the cost of such a changeover. The optimal changeover policies in regions l and f are symmetric to those in regions a and b , respectively, with the roles of x_1 and x_3 being reversed.

Table 3-6. Optimal policy $\mu^*(s, R)$ for the 3-grade example

R	s			Description
	1	2	3	
a	1	1	2	Changeover to the next lower grade
b	1	1	3	If set up for grade 2, changeover to grade 1
c	1	2	2	If set up for grade 3, changeover to grade 2
d	1	2	3	Do not changeover
e	1	3	2	If set up for grade 2 or 3, changeover to grade 3 and 2, respectively
f	1	3	3	If set up for grade 2, changeover to grade 3
g	2	1	2	If set up for grade 1 or 3, changeover to grade 2; if set up for grade 2, changeover to grade 1
h	2	1	3	If set up for grade 1 or 2, changeover to grade 2 and 1, respectively
i	2	2	2	Changeover to grade 2
j	2	2	3	If set up for grade 1, changeover to grade 2
k	2	3	2	If set up for grade 1 or 3, changeover to grade 2; if set up for grade 2, changeover to grade 3
l	2	3	3	Changeover to the next higher grade

The structure of the optimal changeover policy, described above, which holds for very high values of x_2 , also holds for smaller values of x_2 , as seen by Figure 3-3 (right), where $x_2 (= 70) > x_1 + x_3$.

Figure 3-4 (left), shows the optimal changeover policy when $x_2 (= 30) < x_1 + x_3$. As can be seen from that figure, in addition to regions a , b , f and l , three new regions enter the picture, namely, regions c , d and j . If $(x_1, x_3) \in c$, in which case $x_3 \gg x_2 > x_1$, then the facility must change over to grade 2, if it is set up for grade 3. If it is set up for grade 2, however, it need not change over

to grade 1, because x_1 is not that much lower than x_2 to justify the cost of such a changeover. If $(x_1, x_3) \in d$, in which case the inventory levels of the three grades are not that different from each other, then the facility need not change over at all, no matter what grade it is set up for. The optimal changeover policy in region j is symmetric to that in region c , with the roles of x_1 and x_3 being reversed.

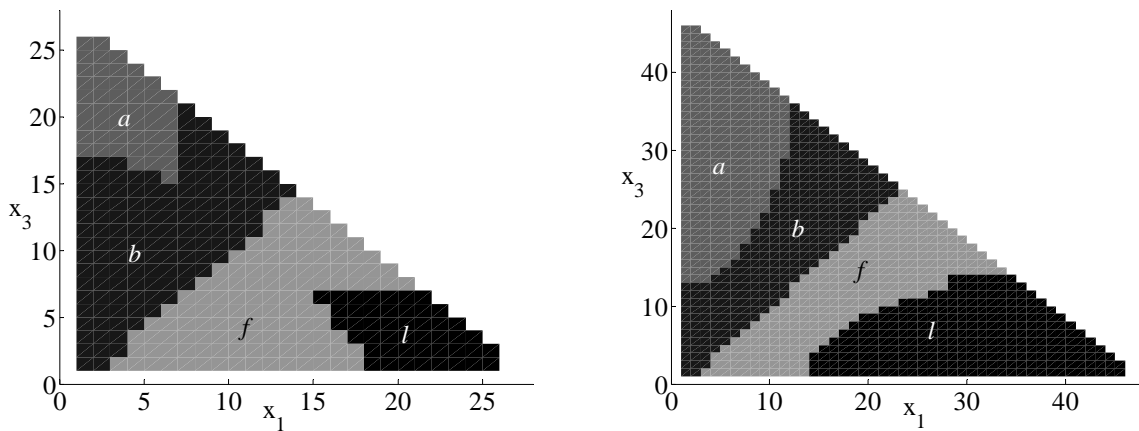

Figure 3-3. Optimal changeover policy for $x_2 = 90$ (left) and $x_2 = 70$ (right), for the 3-grade example

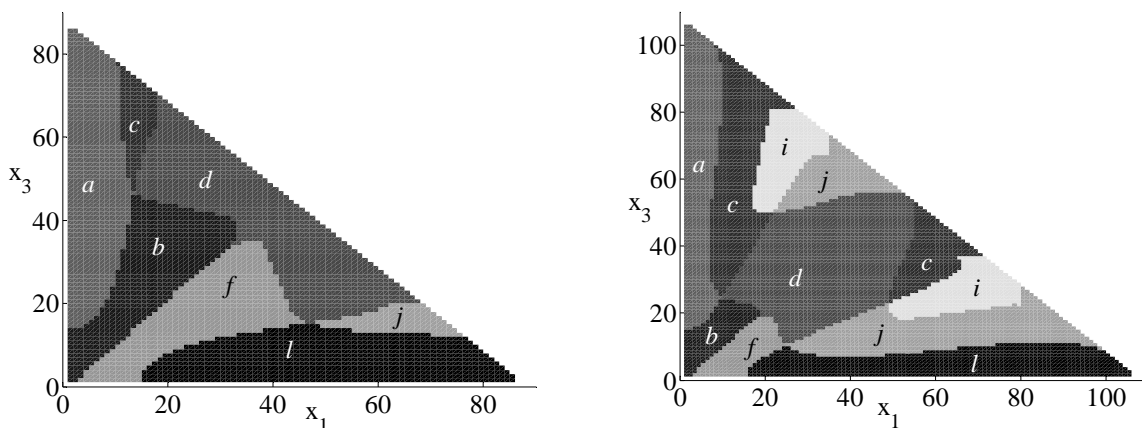

Figure 3-4. Optimal changeover policy for $x_2 = 30$ (left) and $x_2 = 10$ (right), for the 3-grade example

Finally, Figure 3-4 (right), shows the optimal changeover policy when $x_2 (= 10) \ll x_1 + x_3$. As can be seen from that figure, in addition to the regions that appear in Figure 3-4 (left), four new regions enter the picture, namely, regions i (top-left), j (top), c (right), and i (bottom-right). If $(x_1, x_3) \in i$ (top-left), in which case $x_3 \gg x_1 > x_2$, then the facility must change over to grade 2. More specifically, if the facility is set up for grade 1, then it must change over to grade 2, simply because $x_2 < x_1$. If the facility is set up for grade 3, on the other hand, then it must change over to grade 2 mostly to be in a better position to change over to grade 1, if needed, given that x_1 is also low and is being depleted at a faster rate than x_2 . If $(x_1, x_3) \in j$ (top-left), in which case $x_3 > x_1 \gg x_2$, then the facility must change over to grade 2, if it is set up for grade 1, because $x_2 \ll x_1$. If it is set up for grade 3, however, it need not change over to grade 2, because it is no longer necessary to be in a better position to change over to grade 1, if needed, given that x_1 in region j is not as low as it is in region i (top-left). The optimal changeover policies in regions c (right) and i (bottom-right) are symmetric to those in regions j (top) and i (top-left), respectively, with the roles of x_1 and x_3 being reversed.

Table 3-7 shows the elements of the optimal target inventory level vector for each set up state s . As in the 2-grade example, the optimal target inventory level of the grade being produced is close to zero, whereas the optimal target inventory level of the grades not being produced are positive and quite big. In fact, the further away (in terms of number of changeovers) a grade is from the grade produced, the higher its optimal target inventory level.

Table 3-7. Optimal target inventory level, $x_n^*(s)$, for the 3-grade example

	n		
s	1	2	3
1	2	22	47
2	22	3	56
3	47	31	3

3.4.3 4-grade and 5-grade examples

Finally, we consider a 4-grade ($N = 4$) and a 5-grade ($N = 5$) example. In each example, we assume that the demand for each grade is identically distributed to one of the random variables D_j , $j = A, B, C, D$, whose distributions are given in Table 3-8.

Table 3-8. Probability distribution of demand, $\Pr(D_j = i)$, for the 4-grade and 5-grade examples

j	i				$E[D_j]$
	0	1	2	3	
A	0.4	0.5	0.05	0.05	0.75
B	0.25	0.5	0.25	0	1
C	0.25	0.25	0.5	0	1.25
D	0.05	0.2	0.45	0.3	2

For each example, we consider four different cases. In each case, the set of the probability distributions of the demands of the different grades is the same and such that the total expected demand is equal to the production rate. The difference between the cases is in the order in which these distributions appear in the chain of allowable changeovers. For instance, in all cases of the 4-grade example, we assume that the demands of two of the grades are identically distributed to random variable D_B , which has an expected value of 1, and the demands of the other two grades are identically distributed to random variable D_D , which has an expected value of 2. In other words, two grades have low demand and two grades have high demand. In case 1, the grades with the low demand are the end grades, 1 and 4, whereas the grades with the high demand are the middle grades, 2 and 3. To indicate this order we use the notation “ B,D,D,B ”. In case 2, the order is D,D,B,B , which means that grades 1 and 2 have high demand and grades 3 and 4 have low demand, and so on. Hence, each case represents a different way that total expected demand is distributed among the individual grades.

First, we solved each case optimally using the successive approximation procedure described in Section 3.2, for convergence tolerance criterion $\varepsilon = 0.001$. Then, we solved each case using the heuristic procedure described in Section 3.3. In the implementation of the heuristic procedure we employed the faster alternative to approximate the sum of the expected lost sales of the individual grades, described at the end of Section 3.3, which uses expression (3.5) to estimate the aggregate inventory levels of the composite grades, for values of α ranging from 0 to 1 with a step size of 0.1. In all cases, we assumed that $CC = CS = CL_n = 1$, $n = 1, \dots, 5$, and $P = 6$.

The results for the 4-grade example, for $X = 30$, are shown in Table 3-9. The CPU times reported are in hours on an Intel Core i7 PC at 2.67 GHz with 3 GB RAM. For the heuristic, we show the total CPU time in hours that it took to solve the $(N - 2)$ 3-grade sub-problems and generate the heuristic policy, but not the time it took to evaluate the heuristic policy. As was mentioned at the end of Section 3.3, the time it takes to evaluate the heuristic policy using the value iteration method is significant, whereas the alternative of using discrete-time system simulation is much faster. In all cases of the 4-grade problem, we used the value iteration method. The optimal value of α in the heuristic procedure is denoted by α^* , and the corresponding expected average cost per period is denoted by $J^h(\alpha^*)$. The last column of Table 3-9 shows the percent cost increase between the heuristic and the optimal policy. The complete set of the results of the heuristic policy evaluated both with the value iteration method and simulation, for different values of α , are shown in Appendix E.

In case 1, the grades with the highest expected demands are in the middle of the chain of allowable changeovers, whereas in case 4, they are at the two ends of the chain. Hence, case 1 represents a situation where the dispersion of the total expected demand among the individual grades is relatively low, because most of the time the production facility will be changing over between the highly demanded grades, 2 and 3, which are adjacent. Case 4, on the other hand,

represents a situation where the dispersion of the total expected demand is relatively high, because most of the time the production facility will be changing over between the highly demanded grades, 1 and 4, which are spaced 3 grades apart. Cases 2 and 3 are intermediate cases.

Table 3-9. Results for the 4-grade example

Case	Demand pattern	Exact			Heuristic			% cost difference
		k_c	CPU	J	CPU	α^*	$J^h(\alpha^*)$	
1	<i>B,D,D,B</i>	55	8.57	1.0034	0.0461	0.7	1.2442	24.00
2	<i>D,D,B,B</i>	156	24.29	1.0927	0.0574	0.5	1.2253	12.13
3	<i>D,B,D,B</i>	187	29.12	1.1835	0.0748	0.1	1.3207	11.59
4	<i>D,B,B,D</i>	110	17.13	1.2881	0.1040	0.1	1.3139	1.96

From the results, it can be seen that as we move from case 1 to case 4, i.e., as the dispersion of the total demand among the individual grades increases, the expected average cost per period increases, because the number of changeovers needed to effectively meet the demands for all the grades increases. To see this, note that in case 1, every time the facility must change over between the highly demanded grades, 2 and 3, one changeover is needed, namely, 2→3. In case 4, however, when the facility must change between the highly demanded grades, 1 and 4, three costly but inevitable changeovers are needed, namely 1→2, 2→3, and 3→4. During the latter two changeovers, the lowly demanded grades, 2 and 3, are each produced for one period. These inevitable single-period production runs result in preventing the inventory levels of grades 2 and 3 from dropping too much on average, which would cause a significant imbalance among the inventory levels of all the grades. This then suggests that the bigger the dispersion of the total demand among the individual grades, the smaller the imbalance problem. Moreover, as was mentioned in Section 3.3, the smaller the imbalance problem, the smaller the optimal value of α , and the better the performance of the heuristic. This explains why, as we move from case 1 to case 4, α^* and the percent cost increase between the heuristic and the optimal policy decrease. Actually,

in all cases, except case 1, $J^h(\alpha)$ is relatively insensitive to parameter α , as can be seen from Figure 3-5. Case 1 tends to have lower cost for α between 0.5 and 0.7 and significantly higher cost for α between 0.8 and 1.

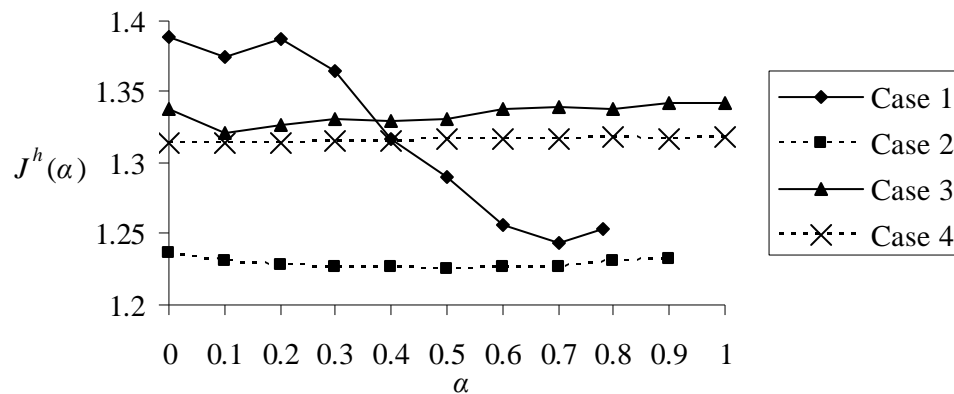

Figure 3-5. Expected average cost per period of the heuristic, $J^h(\alpha)$, vs. α , for the 4-grade example

Finally, the cost increase when using the heuristic instead of the exact method is 12.42% on average and ranges between 1.96% for case 4 and 24% for case 1. Note, however, that the heuristic method is between 160 and 420 times faster than the exact method.

The results for the 5-grade example, for $X = 20$, are shown in Table 3-10. In all cases, we used discrete-time system simulation to evaluate the heuristic policy. To obtain each estimate $J^h(\alpha)$ and its 95% confidence interval, denoted by “c.i.”, we run 60 simulations, each with a time horizon of 100,000 time units. The complete set of the results of the heuristic policy evaluated with simulation, for different values of α , are shown in Appendix E.

The results are qualitatively similar to those obtained for the 4-grade example. Namely, the smaller the imbalance problem, the smaller the optimal value of α , and the better the performance of the heuristic. In all cases of this example, α^* is quite small and $J^h(\alpha)$ is slightly increasing and

relatively insensitive to parameter α , at least for values of α smaller than 0.5, as can be seen from Figure 3-6. The cost increase when using the heuristic instead of the exact method ranges between 7.59% for case 4 and 14.46% for case 1 and is 12.75% on average, which is practically the same as the average cost difference in the 4-grade example. The heuristic method, however, is between 600 and 1700 times faster than the exact method, which is quite significant.

Table 3-10. Results for the 5-grade example

Case	Demand pattern	k_c	Exact		Heuristic			% cost increase
			CPU	J	CPU	α^*	$J^h(\alpha^*)$ (95% c.i.)	
1	A,C,D,C,A	35	38.05	2.6520	0.0223v	0.1	3.0355 ± 0.0016	14.46
2	D,C,C,A,A	71	78.70	3.0016	0.1293v	0.1	3.4512 ± 0.0015	14.98
3	D,C,A,A,C	129	141.21	3.4916	0.1761v	0	3.8759 ± 0.0020	11.00
4	D,A,C,A,C	129	140.39	3.6572	0.1758v	0	3.9348 ± 0.0020	7.59

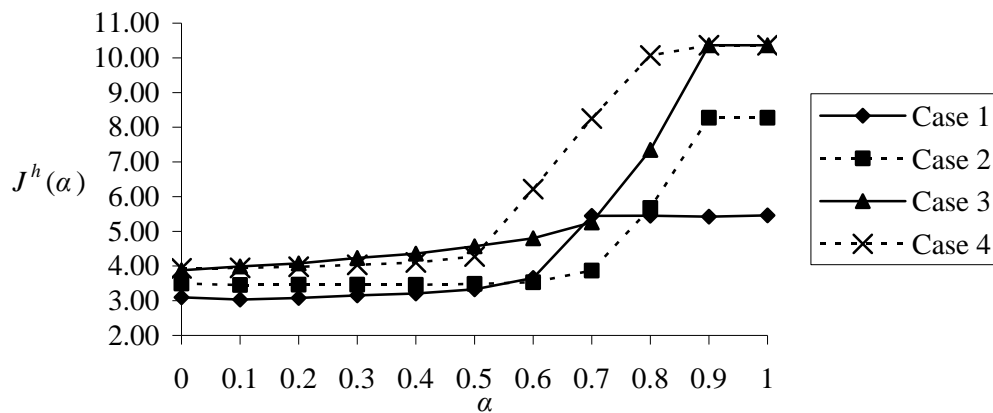

Figure 3-6. Expected average cost per period of the heuristic, $J^h(\alpha)$, vs. α , for the 5-grade example

3.5 Conclusions

We studied a new version of the SELSP, for which we developed a MDP model. For problems with 2 and 3 grades, we numerically solved the MDP problem and obtained useful insight into the influence of the problem parameters and structure of the optimal changeover policy, which

partitions the state space into different regions, each characterized by different optimal changeover actions.

For problems with N grades, $N > 3$, we developed a heuristic solution procedure which is based on approximating the original multi-grade problem by $(N - 2)$ 3-grade sub-problems and numerically solving each sub-problem. We tested the heuristic for problems with 4 and 5 grades. For the 4-grade examples, the heuristic procedure was 160-420 times faster than the numerical procedure for solving the exact problem and the heuristic solution performed on average 12.42% worse than the exact solution. For the 5-grade examples, the heuristic procedure was 600-1700 times faster than the numerical procedure for solving the exact problem and the heuristic solution performed on average 12.75% worse than the exact solution. The fact that the performance of the heuristic solution is more or less the same for the 4-grade and 5-grade problems is an encouraging sign for problems with more than 5 grades. The numerical results showed that the bigger the dispersion of the total expected demand among the individual grades, the better the performance of the heuristic.

We can easily solve problems with more than 5 grades using the heuristic; however, it is impossible to compare the performance of the changeover policy that the heuristic generates to that of the optimal changeover policy, because it is impossible to even start the value iteration method to find the optimal policy, as the state space grows dramatically with the number of grades and simply there is not enough computer memory to store it. For example, for a problem with $N = 6$ and $X = 20$, the state space contains $(6 \cdot 20^6)/2 = 192 \times 10^6$ points.

Chapter 4 Dissertation summary

In Chapter 2, we developed an MILP model for the production scheduling of a multi-grade PET processing chemical plant. We also presented an application of the model on a real case study, along with some discussion that provides insight into its behavior. The model minimizes the cost associated with the number of grade changeovers, while also ensuring that the capacity constraints of the problem are not violated and that the demand for final products is satisfied on time. The model incorporates all aspects of the problem under consideration and can be easily extended to address additional ones that may arise in different situations, because of the large number of decision variables that enhances its flexibility. We believe that the main contribution of this work is that it addresses efficiently an important practical application, whose solution exhibits high complexity.

A number of possible directions for future research arise from this work. Firstly, one could try to develop a continuous-time model formulation for this problem and compare its results to those of the discrete-time model that we present here. Our guess is that the development of such a model would be demanding and would not necessarily be computationally more efficient than the present discrete-time model. It would, however, represent more accurately the real production and storage process, which is continuous in nature. A second possible direction would be to relax some of the hard constraints, e.g. the on-time delivery of demand constraints (2.24), (2.25) and (2.27) and/or the safety stock constraints (2.21) and (2.29), as was discussed at the end of Section 3, and

see if this leads to significant benefits. Another possible direction would be to develop a more accurate SELSP formulation than the one presented in Chapter 3 to better design the safety stock levels, or resort to some stochastic integer programming technique to solve the scheduling problem under uncertainties. A recent work relevant to this subject is due to Sand and Engell (2004), who utilize two-stage stochastic integer programming techniques to solve scheduling problems of flexible chemical batch processes that exhibit uncertainties. Finally, one could try to fit the scheduling model developed in this dissertation within a broader planning and supply chain framework, e.g., as discussed in Kallrath (2002).

In Chapter 3, we studied a new version of the SELSP, for which we developed a MDP model. For problems with 2 and 3 grades, we numerically solved the MDP problem and obtained useful insight into the influence of the problem parameters and structure of the optimal changeover policy, which partitions the state space into different regions, each characterized by different optimal changeover actions.

For problems with N grades, $N > 3$, we developed a heuristic solution procedure which is based on approximating the original multi-grade problem by $(N - 2)$ 3-grade sub-problems and numerically solving each sub-problem. We tested the heuristic for problems with 4 and 5 grades. For the 4-grade examples, the heuristic procedure was 160-420 times faster than the numerical procedure for solving the exact problem and the heuristic solution performed on average 12.42% worse than the exact solution. For the 5-grade examples, the heuristic procedure was 600-1700 times faster than the numerical procedure for solving the exact problem and the heuristic solution performed on average 12.75% worse than the exact solution. The fact that the performance of the heuristic solution is more or less the same for the 4-grade and 5-grade problems is an encouraging sign for problems with more than 5 grades. The numerical results showed that the bigger the

dispersion of the total expected demand among the individual grades, the better the performance of the heuristic.

We can easily solve problems with more than 5 grades using the heuristic; however, it is impossible to compare the performance of the changeover policy that the heuristic generates to that of the optimal changeover policy, because it is impossible to even start the value iteration method to find the optimal policy, as the state space grows dramatically with the number of grades and simply there is not enough computer memory to store it. For example, for a problem with $N = 6$ and $X = 20$, the state space contains $(6 \cdot 20^6)/2 = 192 \times 10^6$ points.

A possible direction for future research would be to try to develop a better heuristic that somehow uses the optimal value functions of the sub-problems, although we should point out that our initial experimentation with this possibility has not been encouraging. Another direction would be to extend the model so as to accommodate other types of FG storage than the common FG buffer that we assumed in our model. For example, one could consider multiple parallel FG buffers (e.g., industrial silos) that can store only one grade at a time, or two serial FG buffers, e.g., one for storing bulk FGs and the second for storing packaged FGs, as is the case in the real application described in Chapter 2.

Bibliography

- Anupindi, R., Tayur, S. 1998. Managing stochastic multiproduct systems: model, measures, and analysis. *Operations Research* 46 (3) S98-S111.
- Bok, J. and Park, S., (1998). Continuous-time modeling for short-term scheduling of multipurpose pipeless plants. *Industrial and Engineering Chemistry Research* 37 (9), 3652-3659.
- Bourland, K.E., Yano, C.A. 1994. The strategic use of capacity slack in the economic lot scheduling problem with random demand. *Management Science* 40 (12) 1690-1704.
- Castro, P.M. and Grossmann, I.E., (2006). An efficient MILP model for short-term scheduling of single stage batch plants. *Computers and Chemical Engineering* 30, 1003-1018.
- Chase, C., Serrano, J., Ramadge, P.J. 1993. Periodicity and chaos from switched flow systems: contrasting examples of discretely controlled continuous systems. *IEEE Transactions on Automatic Control* 38 (1), 70-83.
- Dallery, Y. and Gershwin, S.B. (1992). Manufacturing flow line systems: A review of models and analytical results. *Queueing Systems* 12 (1-2), 3-94.
- Doganis, P., Sarimveis, H., Bafas, G. and Koufos, D., (2005). An MILP model for optimal scheduling of the lubricant production plant. *Chemical Engineering Communications* 192 (8), 1067-1084.

- Elhafsi, M., Bai, S.X. 1997. Optimal and near-optimal control of a two-part-type stochastic manufacturing system with dynamic setups. *Production and Operations Management* 6 (4) 419-438.
- Elmaghraby, S.E. 1978. The economic lot scheduling problem (ELSP): review and extensions. *Management Science* 24 (6), 587-598.
- Federgruen, A., Katalan, Z. 1996. The stochastic economic lot scheduling problem: cyclical base stock policies with idle times. *Management Science* 42 (6) 783-796.
- Floudas, C.A. and Lin, X., (2004). Continuous-time versus discrete time approaches for scheduling of chemical processes: A review. *Computers and Chemical Engineering* 28 (11), 2109-2129.
- Floudas, C.A. and Lin, X., (2005). Mixed integer linear programming in process scheduling: Modeling, algorithms, and applications. *Annals of Operations Research* 139 (1), 131-162.
- Fourer, R., Gay, D.M. and Kernighan, B.W., (2002). *AMPL: A Modeling Language for Mathematical Programming*. Duxbury Press.
- Fransoo, J.C., Sridharan, V., Bertrand, J.W.M. 1995. A hierarchical approach for capacity coordination in multiple products single-machine production systems with stationary stochastic demands. *European Journal of Operational Research* 86 (1) 57-72.
- Gallego, G. 1990. Scheduling the production of several items with random demands in a single facility. *Management Science* 36 (12) 1579-1592.
- Gallego, G. 1994. When is a base stock policy optimal in recovering disrupted cyclic schedules? *Naval Research Logistics* 41 (1) 317-333.
- Giannelos, N.F. and Georgiadis, M.C., (2002). A novel event-driven formulation for short-term scheduling of multipurpose continuous processes. *Industrial and Engineering Chemistry Research* 41 (10), 2431-2439.

- Graves, S.C. 1980. The multi-product production cycling problem. *AIIE Transactions* 12 (3), 233-240.
- Grossmann, I.E., Quesada, J., Raman, R. and Voudouris, V., (1996). Mixed integer optimization techniques for the design and scheduling of batch processes, *Batch Processing Systems Engineering*, G. V. Reklaitis, A. K. Sunol, D. W. T. Rippin and O. Hortacsu (eds.), Springer, Berlin, 451-494.
- Grünow, M., Günther, H-O. and Lehman, M. (2002). Campaign planning for multi-stage batch processes in the chemical industry. *OR Spectrum* 24 (3), 281-314.
- Hui, C., Gupta, A. and van der Meulen, H.A.J., (2000). A novel MILP formulation for short-term scheduling of multi-stage multi-product batch plants with sequence-dependent constraints. *Computers and Chemical Engineering* 24 (12), 2705-2717.
- Ierapetritou, M.G. and Floudas, C.A., (1998a). Effective continuous-time formulation for short-term scheduling. I. Multipurpose batch processes. *Industrial and Engineering Chemistry Research* 37 (11), 4341-4359.
- Ierapetritou M.G. and Floudas, C.A., (1998b). Effective continuous-time formulation for short-term scheduling. II. Continuous and semicontinuous processes. *Industrial and Engineering Chemistry Research* 37 (11), 4360-4374.
- Janak, S.L. and Floudas, C.A., (2008). Improving unit-specific event based continuous-time approaches for batch processes: Integrality gap and task splitting. *Computers and Chemical Engineering* 32, 913-955.
- Janak, S.L., Lin, X. and Floudas, C.A., (2004). Enhanced continuous-time unit-specific event based formulation for short-term scheduling of multipurpose batch processes: Resource constraints and mixed storage policies. *Industrial and Engineering Chemistry Research* 43 (10), 2516-2533.

- Janak, S.L., Floudas, C.A., Kallrath, J. and Vormbrock, N., (2006a). Production scheduling of a large-scale industrial batch plant. I. Short-term and medium-term scheduling. *Industrial and Engineering Chemistry Research* 45 (25), 8234-8252.
- Janak, S.L., Floudas, C.A., Kallrath, J. and Vormbrock, N., (2006b). Production scheduling of a large-scale industrial batch plant. II. Reactive scheduling. *Industrial and Engineering Chemistry Research* 45 (25), 8253-8269.
- Kallrath, J., (2002). Planning and scheduling in the process industry. *OR Spectrum* 24 (3), 219-250.
- Karmarkar, U.S., Yoo, J. 1994. The stochastic dynamic product cycling problem. *European Journal of Operational Research* 73 (2), 360-373.
- Kimemia, J.G., Gershwin, S.B. 1983. An algorithm for the computer control of production in flexible manufacturing systems. *IIE Transactions* 15 (4), 353-362.
- Kondili, E., Pantelides, C.C. and Sargent, R.W.H., (1993). A general algorithm for short-term scheduling of batch operations. I. MILP formulation. *Computers and Chemical Engineering* 17 (2), 211-227.
- Leachman, R.C., Gascon, A. 1998. A heuristic policy for multi-item, single-machine production systems with time-varying stochastic demands. *Management Science* 34 (3) 377-390.
- Lee, H.M., Pinto, J.M. and Grossmann, I.E., (1996). Mixed-integer linear programming model for refinery short-term scheduling of crude oil unloading with inventory management. *Industrial and Engineering Chemistry Research* 35 (5), 1630-1641.
- Liberopoulos, G., Caramanis, M. 1997. Numerical investigation of optimal policies for production flow control and set-up scheduling: lessons from two-part-type failure prone FMSs. *International Journal of Production Research* 35 (8), 2109-2133.

- Lin, X. and Floudas, C.A., (2001). Design, synthesis and scheduling of multipurpose batch plants via an effective continuous-time formulation. *Computers and Chemical Engineering* 25, 665-674.
- Mahadevan, R., Doyle, F.J.III and Allcock, A.C., (2007). Control-relevant scheduling of polymer grade transitions. *AIChE Journal* 48 (8), 1754-1764.
- Markowitz, D.M., Reiman, M.I., Wein, L.M. 2000. The stochastic economic lot scheduling problem: heavy traffic analysis of dynamic cyclic policies. *Operations Research* 48 (1) 136-154.
- Markowitz, D.M., Wein, L.M. 2001. Heavy traffic analysis of dynamic cyclic policies: a unified treatment of the single machine scheduling problem. *Operations Research* 49 (2) 246-270.
- McGehee, J.F., Johnson, J.A. and Bertelli, C., (2004). Maximizing PET SSP line profitability through world scale process design and operations. POLYESTER 2004: 9th World Congress, 7-9 December 2004, Zurich, Switzerland.
- Méndez, C.A. and Cerdá, J., (2002). An efficient MILP continuous-time formulation for short-term scheduling of multiproduct continuous facilities. *Computers and Chemical Engineering* 26 (4-5), 687-695.
- Méndez, C.A., Cerdá, J., Grossmann, I.E., Harjunkoski, L. and Fahl, M., (2006). State-of-the art review of optimization methods for short-term scheduling of batch processes. *Computers and Chemical Engineering* 30, 913-946.
- Mockus, L. and Reklaitis, G.V., (1999). Continuous time representation approach to batch and continuous process scheduling: 1. MINLP formulation. *Industrial and Engineering Chemistry Research* 38 (1), 197-203.
- Neumann, K., Schwindt C. and Trautmann, N., (2002). Advanced production scheduling for batch plants in process industries. *OR Spectrum* 24 (3), 251-279.

- Nyström R.H., Franke, R., Harjunkoski, I., and Kroll, A. (2005). Production campaign planning including grade transition sequencing and dynamic optimization. *Computers and Chemical Engineering* 29 (10) 2163-2179.
- Pinto, J.M. and Grossmann, I.E., (1995). A continuous time mixed integer linear programming model for short term scheduling of multistage batch plants. *Industrial and Engineering Chemistry Research* 34 (9), 3037-3051.
- Pinto, J.M., Turkay, A., Bolio, B. and Grossmann, I.E., (1997). A continuous-time MILP optimization for short-term scheduling of batch plants. *Computers and Chemical Engineering* 22 (9), 1297-1308.
- Pinto, J.M. and Grossmann, I.E., (1998). Assignment and sequencing models for the scheduling of process systems. *Annals of Operations Research* 81, 433-466.
- Prata, A., Oldenburg, J., Kroll, A. and Marquardt, W., (2008). Integrated scheduling and dynamic optimization of grade transitions for a continuous polymerization reactor. *Computers and Chemical Engineering* 32 (3), 463-476.
- Qiu, M.M. and Burch, E.E. (1997). Hierarchical production planning and scheduling in a multi-product, multi-machine environment. *International Journal of Production Research* 35 (11), 3023-3042.
- Qiu, J., Loulou, R. 1995. Multiproduct production/inventory control under random demands. *IEEE Transactions on Automatic Control* 40 (2), 350-356.
- Reklaitis, G.V. (1992). Overview of scheduling and planning of batch process operations. NATO Advanced Study Institute – Batch Process Systems Engineering, Antalya, Turkey.
- Salomon, M. 1991. Deterministic lot sizing models for production planning. Lecture Notes in Economics and Mathematical Systems. Springer-Verlag, Berlin.

- Sand, G. and Engell, S. (2004). Modeling and solving real-time scheduling problems by stochastic integer programming. *Computers and Chemical Engineering* 28, 1087-1103.
- Shaik, M.A. and Floudas, C.A., (2007). Improved unit-specific event-based continuous-time model for short-term scheduling of continuous processes: Rigorous treatment of storage requirements. *Industrial and Engineering Chemistry Research* 46 (6), 1764-1779.
- Shaik, M.A., Janak, S.L. and Floudas, C.A., (2006). Continuous-time models for short-term scheduling of multipurpose batch plants: A comparative study. *Industrial and Engineering Chemistry Research* 45 (18), 6190-6209.
- Shaik, M.A., Floudas, C.A., Kallrath, J. and Pitz, H.J., (2009). Production scheduling of a large-scale industrial continuous plant: Short-term and medium-term scheduling. *Computers and Chemical Engineering* 33 (3), 670-686.
- Sharifnia, A., Caramanis, M., Gershwin, S.B. 1991. Dynamic setup scheduling and flow control in manufacturing systems. *Discrete Event Dynamic Systems* 1 (2) 149-175.
- Sox, C.R., Jackson, P.L., Bowman, A., Muckstadt, J.A. 1999. A review of the stochastic lot scheduling problem. *International Journal of Production Economics* 62 (3), 181-200.
- Sox, C.R., Muckstadt, J.A. 1997. Optimization-based planning for the stochastic lot-sizing problem. *IIE Transactions* 29 (5), 349-357.
- Suerie, C. (2005). Time continuity in discrete time models: New approaches for production planning in process industries. *Lectures Notes in Economics and Mathematical Systems*, 552, Springer, Berlin, Germany.
- Terrazas-Moreno, S., Flores-Tlacuahuac, A. and Grossmann, I.E., (2007). Simultaneous cyclic scheduling and optimal control of polymerizations reactors. *AIChE Journal* 53 (9), 2301-2315.
- Tousain, R.L. and Bosgra, O.H., (2006). Market-oriented scheduling and economic optimization of continuous multi-grade chemical processes. *Journal of Process Control* 16 (3), 291 – 302.

- Vergin, R.C., Lee, T.N. 1978. Scheduling rules for the multiple product single-machine system with stochastic demand. *INFOR* 16 (1), 64-73.
- Wang, K., Lohl, T., Stobbe, M. and Engell, S., (2000). A genetic algorithm for online-scheduling of a multiproduct polymer batch plant. *Computers and Chemical Engineering* 24, 393-400.
- Winands, E.M.M., Adan, I.J.B.F., van Houtum, G.J. 2005. The stochastic economic lot scheduling problem: a survey. Working paper. Beta Research School for Operations Management and Logistics, Technical University of Eindhoven.
- Zipkin, P.H. 1986. Models for design and control of stochastic multi-item batch production systems. *Operations Research* 34 (1) 91-104.

Appendix A: Demand data used in the MILP model application presented in Section 2.3

Table A-1. Daily demand values for 6 months used in the example solved in Section 2.3

t	$dST_{1t} + dBC_{1t}$	$dST_{4t} + dBC_{4t}$	dBB_{1t}	dBB_{2t}	dBB_{4t}
1/6/2005	48	25	38.5	55	144.1
2/6/2005	50	25	1.7	90.2	72.6
3/6/2005	50	23	46.2	42.9	24.2
4/6/2005	23	23	0	0	0
5/6/2005	0	0	0	0	0
6/6/2005	73	71	5.5	22	24.2
7/6/2005	73	48	26.4	70.4	96.8
8/6/2005	25	46	80.3	100.1	96.8
9/6/2005	73	23	0	67.1	94.6
10/6/2005	25	71	11	13.1	48.4
11/6/2005	23	23	0	0	0
12/6/2005	25	48	0	0	0
13/6/2005	48	23	25.3	29.7	72.6
14/6/2005	50	46	30.8	38.5	72.6
15/6/2005	73	23	28.6	37.4	23.1
16/6/2005	73	23	36.3	14.3	72.6
17/6/2005	25	46	27.5	48.4	57.2
18/6/2005	46	46	0	0	0
19/6/2005	0	0	0	0	0
20/6/2005	73	23	0	0	0
21/6/2005	75	46	48.4	114.4	71.5
22/6/2005	73	23	0	185.9	95.7
23/6/2005	50	69.38	18.7	51.7	48.4
24/6/2005	71	46	0	0	0
25/6/2005	98	0	0	0	0
26/6/2005	0	0	0	0	0
27/6/2005	0	23	68.2	138.6	121
28/6/2005	75	46	23.1	136.4	143
29/6/2005	73	46	35.2	221.1	0
30/6/2005	98	23	11	107.8	23.1
1/7/2005	73	23	23.1	46.2	163.9
2/7/2005	50	23	0	0	0
3/7/2005	0	23	0	0	0
4/7/2005	97.8	46	47.3	69.3	72.6
5/7/2005	50	23	24.2	113.3	95.7
6/7/2005	98	23	24.2	68.2	119.9
7/7/2005	50	46	5.5	26.4	70.4

8/7/2005	73	23	5.5	63.8	211.2
9/7/2005	48	46	0	0	0
10/7/2005	0	0	0	0	0
11/7/2005	73	23	53.9	105.6	118.8
12/7/2005	50	50	27.5	90.2	116.6
13/7/2005	73	23	34.1	99	9
14/7/2005	50	73	16.5	94.6	40
15/7/2005	48	46	0	23.1	126.2
16/7/2005	23	0	0	0	0
17/7/2005	0	23	0	0	0
18/7/2005	73	23	53.9	77	94.6
19/7/2005	73	23	28.6	0	139.7
20/7/2005	75	46	55	93.5	60.5
21/7/2005	73	23	0	107.8	35.2
22/7/2005	73	46	35.2	93.5	119.9
23/7/2005	25	46	0	0	0
24/7/2005	0	0	0	0	0
25/7/2005	73	23	48.4	23.1	46.2
26/7/2005	73	46	0	0	0
27/7/2005	73	23	94.6	91.3	45.1
28/7/2005	50	71	92.4	22	90.2
29/7/2005	98	25	61.6	111.1	0
30/7/2005	0	23	0	0	0
31/7/2005	124.17	23	0	0	0
1/8/2005	50	46	52.8	115.5	0
2/8/2005	96	23	113.3	20.9	66
3/8/2005	50	48	91.3	45.1	92.4
4/8/2005	48	23	20.4	96.8	38.5
5/8/2005	50	46	23.1	68.2	44
6/8/2005	23	23	0	0	0
7/8/2005	23	23	0	0	0
8/8/2005	50	46	23.1	89.1	47.3
9/8/2005	73	23	67.1	90.2	47.3
10/8/2005	73	23	44	46.2	0
11/8/2005	0	71	90.2	166.1	48.4
12/8/2005	73	23	23.1	136.4	47.3
13/8/2005	23	23	0	0	0
14/8/2005	0	0	0	0	0
15/8/2005	0	23	0	0	0
16/8/2005	48	46	23.1	90.2	0
17/8/2005	48	71	89.1	0	69.3
18/8/2005	75	48	0	92.4	23.1
19/8/2005	48	221	23.1	46.2	46.2
20/8/2005	23	23	0	0	0
21/8/2005	0	23	0	0	0
22/8/2005	48	23	23.1	22	47.3
23/8/2005	50	71	48.4	66	46.2
24/8/2005	23	46	23.1	110	0

25/8/2005	46	202	47.3	66	23.1
26/8/2005	50	23	49.5	0	46.2
27/8/2005	0	48	0	0	0
28/8/2005	0	23	0	0	0
29/8/2005	48	23	89.1	121	70.4
30/8/2005	25	71	45.1	89.1	23.1
31/8/2005	23	46	24.2	63.8	0
1/9/2005	50	48	45.1	44.01	0
2/9/2005	46	46	23.11	86.91	24.21
3/9/2005	23	23	0	0	0
4/9/2005	0	25	0	0	0
5/9/2005	73	23	91.3	0	0
6/9/2005	25	46	24.2	23.1	0
7/9/2005	73	23	58.3	24.2	13.2
8/9/2005	48	48	0	0	0
9/9/2005	48	46	47.3	20.9	92.4
10/9/2005	23	23	0	0	0
11/9/2005	100	0	0	0	0
12/9/2005	0	48	13.2	260.4	17.6
13/9/2005	74	49	47.3	69.3	24.2
14/9/2005	50	48	0	67.1	0
15/9/2005	49	24	15.4	181.5	0
16/9/2005	25	49	23.1	23.1	116.6
17/9/2005	24	24	0	0	0
18/9/2005	75	24	0	0	0
19/9/2005	99	24	47.3	20.9	0
20/9/2005	74	24	47.3	23.1	34.1
21/9/2005	110.2	48	35.2	128.7	2.2
22/9/2005	194.7	24	95.7	69.3	2.2
23/9/2005	103.7	48	29.7	116.6	24.2
24/9/2005	0	0	0	0	0
25/9/2005	75	48	0	0	0
26/9/2005	74	0	0	48.4	71.5
27/9/2005	147.1	0	23.1	117.7	24.2
28/9/2005	271.7	24	172.7	300.3	0
29/9/2005	144.9	48	20.9	165	24.2
30/9/2005	50	48	0	276.1	39.6
1/10/2005	24	48	0	0	0
2/10/2005	0	24	0	0	0
3/10/2005	50	24	0	23.1	24.2
4/10/2005	97.3	48	47.3	22	2.2
5/10/2005	97.1	48	23.1	0	17.6
6/10/2005	49	24	0	24.2	92.4
7/10/2005	98.2	0	24.2	0	0
8/10/2005	24	24	0	0	0
9/10/2005	49	24	0	0	0
10/10/2005	72.3	48	47.3	0	0
11/10/2005	97.7	24	23.7	20.9	24.2

12/10/2005	48.1	24	23.1	0	0
13/10/2005	99	24	0	27.5	24.2
14/10/2005	25.3	48	25.3	39.6	92.4
15/10/2005	0	0	0	0	0
16/10/2005	49	24	0	0	0
17/10/2005	73.2	24	24.2	0	0
18/10/2005	131.1	24	56.1	59.4	40.7
19/10/2005	49	0	0	42.9	0
20/10/2005	50	24	0	0	0
21/10/2005	48.4	72	0	0	69.3
22/10/2005	0	24	0	0	0
23/10/2005	24	24	0	0	0
24/10/2005	78.4	48	4.4	0	0
25/10/2005	95.4	24	70.4	23.1	46.2
26/10/2005	98	48	0	26.4	0
27/10/2005	46.2	24	46.2	0	24.2
28/10/2005	0	0	0	0	0
29/10/2005	24	48	0	0	0
30/10/2005	0	24	0	25	0
31/10/2005	222.5	48	148.5	44	165
1/11/2005	49.2	24	24.2	23.1	48.4
2/11/2005	142.5	24	93.5	23.1	48.4
3/11/2005	49	48	0	96.8	0
4/11/2005	45.1	24	45.1	0	0
5/11/2005	0	0	0	0	0
6/11/2005	24	24	0	0	0
7/11/2005	73.4	48	48.4	49.2	199.1
8/11/2005	49	24	0	3.3	0
9/11/2005	213.7	24	139.7	213.4	0
10/11/2005	83.4	24	59.4	24.2	46.2
11/11/2005	72.4	48	48.4	80.3	0
12/11/2005	0	24	0	0	0
13/11/2005	25	24	0	0	0
14/11/2005	133.2	24	35.2	0	179.3
15/11/2005	25	24	0	29.7	115.5

Appendix B: Single 2-week MILP problem results vs. two 1-week MILP problem results for the MILP model application presented in Section 2.3

Table A-2. Optimal cost (number of changeovers) and CPU time for each of the 100 instances of the numerical example presented in Section 2.3, where we solved the scheduling problem for weeks 5 and 6 as a single 2-week MILP problem and as two sequential 1-week MILP problems, respectively

Instance	Single 2-week MILP problem		Two 1-week MILP problems		
	CPU(sec)	Optimal Cost	CPU(sec)	CPU(sec)	Optimal Cost
	week 5 + week 6	week 5 + week 6	week 5 + week 6	week 5 (= 20.02) + week 6	week 5 (= 3) + week 6
1	179.28	3	202.4	222.42	5
2	127.31	3	3.21	23.23	5
3	135.04	3	2.99	23.01	5
4	189.95	3	56.79	76.81	5
5	738.3	3	587	607.02	INF
6	189.8	3	2.49	22.51	5
7	121.3	3	4.01	24.03	5
8	155.5	3	3.17	23.19	5
9	198.3	3	6.33	26.35	5
10	141.3	3	5.44	25.46	5
11	111.4	3	250.36	270.38	5
12	1210.9	3	407	427.02	INF
13	144.3	3	4.01	24.03	5
14	99.98	INF	0.22	20.24	INF
15	158.41	3	94.34	114.36	5
16	148.56	3	6.46	26.48	5
17	268.66	3	250.86	270.88	5
18	138.39	3	121.24	141.26	5
19	137.41	3	5.93	25.95	5
20	118.88	3	5.49	25.51	5

21	226.54	3	1.29	21.31	5
22	156.59	3	5.99	26.01	5
23	204.75	3	4.67	24.69	5
24	200.52	3	12.98	33	5
25	216.71	3	48.45	68.47	5
26	142.29	3	5.34	25.36	5
27	266.48	3	201.35	221.37	5
28	296.78	3	200.64	220.66	5
29	218.37	3	0.42	20.44	INF
30	187.51	3	104.03	124.05	5
31	119.41	3	0.92	20.94	INF
32	158.06	3	499.56	519.58	5
33	112.16	INF	0.21	20.23	INF
34	216.4	3	46.65	66.67	5
35	182.61	3	4.13	24.15	5
36	152.77	3	5.03	25.05	5
37	183.51	3	1.42	21.44	INF
38	151.94	3	99.65	119.67	5
39	207.92	3	4.09	24.11	5
40	130.38	3	1.86	21.88	INF
41	115.82	3	0.18	20.2	INF
42	109.77	3	30.47	50.49	5
43	142.81	3	10.46	30.48	5
44	157.61	3	5.02	25.04	5
45	124.11	3	23.62	43.64	5
46	183.66	3	4.47	24.49	5
47	145.49	3	3.53	23.55	5
48	131.75	3	3.33	23.35	5
49	137.27	3	503.62	523.64	5
50	131.76	3	57.36	77.38	5
51	437.94	3	1.2	21.22	5
52	102.41	3	35.03	55.05	5
53	430.61	3	29.6	49.62	5
54	200.77	3	273.2	293.22	5
55	219.12	3	69.33	89.35	5
56	130.44	3	161.98	182	5
57	163.76	3	52.2	72.22	5
58	159.11	3	51.4	71.42	5
59	177.42	3	173.9	193.92	5
60	152.49	3	163.26	183.28	5

61	163.03	3	1.88	21.9	5
62	156.66	3	5.22	25.24	5
63	112.38	INF	0.24	20.26	INF
64	218.07	3	46.01	66.03	5
65	183.01	3	390.63	410.65	5
66	150.34	3	157.71	177.73	5
67	183.84	3	464.11	484.13	5
68	152.08	3	4.81	24.83	5
69	204.85	3	137.9	157.92	5
70	131.61	3	143.15	163.17	5
71	114.78	3	4.71	24.73	5
72	109.13	3	68.9	88.92	5
73	142.85	3	32.9	52.92	5
74	156.07	3	3.29	23.31	5
75	123.44	3	5.98	26	5
76	183.85	3	31.35	51.37	5
77	146.31	3	48.62	68.64	5
78	131.57	3	119.8	139.82	5
79	136.55	3	139.11	159.13	5
80	131.43	3	54.03	74.05	5
81	435.12	3	2.53	22.55	5
82	101.27	3	5.22	25.24	5
83	426.44	3	4.37	24.39	5
84	202.55	3	3.32	23.34	5
85	221.36	3	4.31	24.33	5
86	131.39	3	6.73	26.75	5
87	163.82	3	3.91	23.93	5
88	159.19	3	321.16	341.18	5
89	175.32	3	2.72	22.74	5
90	151.38	3	387.8	407.82	5
91	163.8	3	158.36	178.38	5
92	234.86	3	363.72	383.74	5
93	113.78	3	20.18	40.2	5
94	200.03	3	257.8	277.82	5
95	149.38	INF	1.92	21.94	INF
96	66.81	INF	1.66	21.68	INF
97	136.98	3	433.7	453.72	5
98	143.39	3	50.47	70.49	5
99	68.08	INF	1.68	21.7	INF
100	114.87	3	117.65	137.67	5

Appendix C: AMPL codes for the MILP problem developed

in Section 2.2

AMPL code for the MILP formulation presented in Section 2.2: VPI6months.txt

```
set I;      # set of colors
set J;      # set of final grades
set Q;      # set of silos
set V;      #number of loops
param T;    # time
param P;    # amount produced in one period
param M;    # number of slots in SSP
param N;    # number of slots in TSS
param C;    # cost coefficient 1
param D;    # cost coefficient 2
param B;    # duration of a color transition
param F;    # duration of a viscosity transition (always even)
param dST{j in J,t in N+M+1..T};
param dBC{j in J,t in N+M+1..T};
param dBB{j in J,t in N+M+1..T};
param uST;
param uBC;
param uBB;
param Rmax;
param R0{J};
param Rmin{J};
param Smax;
param Smin;
param S0{q in Q,j in J};
param SS{j in J};
param Z0;
param X0{I,1..N+M};
param A0{N+M-F+2..N+M};
param W0{Q,J};

var x{I,1..T} binary;
var y{J,N+M+1..T+(F/2)} binary;
var a{N+M-F+2..T} binary;
var z{N+M..T+(F/2)} binary;
var S{Q,J,N+M..T}>=0;
var W{Q,J,N+M..T} binary;
var g{Q,J,N+M+1..T} binary;
var G{Q,J,N+M+1..T}>=0;
var R{J,N+M..T}>=0;
```

```

var b{Q,J,N+M+1..T}>=0;
var f{Q,J,N+M+1..T}>=0;
var h{Q,J,N+M+1..T}>=0;

```

#Objective Function

```

minimize objective: C*sum{t in N+M+1..T} a[t] + (D/B)*sum{t in N+M+1..T}x[2,t];

```

```

subject to one_color {t in 1..T}: sum{i in I} x[i,t] = 1;
subject to color_transition1 {t in 1..T-1}: x[1,t] + x[3,t+1] <= 1;
subject to color_transition2 {t in 1..T-1}: x[3,t] + x[1,t+1] <= 1;
subject to grade_transition1 {t in N+M+1..T+(F/2)-1}: y[1,t] + y[3,t+1] <= 1;
subject to grade_transition2 {t in N+M+1..T+(F/2)-1}: y[3,t] + y[1,t+1] <= 1;
subject to a_within_F {t in N+M-4..T-5}: sum{s in t..t+F-1} a[s] <= 1;
subject to light_for_a {t in N+M+1..T}: a[t] <= x[1,t-N-M];
subject to change_a1 {t in N+M+1-(F/2)..T}: z[t+(F/2)] - z[t+(F/2)-1] <= a[t];
subject to change_a2 {t in N+M+1-(F/2)..T}: z[t+(F/2)] - z[t+(F/2)-1] >= - a[t] ;
subject to change_a3 {t in N+M+1-(F/2)..T}: z[t+(F/2)] + z[t+(F/2)-1] >= a[t];
subject to change_a4 {t in N+M+1-(F/2)..T}: z[t+(F/2)] + z[t+(F/2)-1] <= 2-a[t];
subject to gray_with_high_z {t in N+M+1..T+(F/2)}: x[2,t-N-M] <= z[t];
subject to dark_with_high_z {t in N+M+1..T+(F/2)}: x[3,t-N-M] <= z[t];
subject to grade1_combination {t in M+N+1..T+(F/2)}: y[1,t] >= x[1,t-N-M] -z[t];
subject to grade2_combination {t in M+N+1..T+(F/2)}: y[2,t] >= z[t] + x[1,t-N-M] -1;
subject to grade3_combination {t in M+N+1..T+(F/2)}: y[3,t] >= z[t] + x[2,t-N-M] -1;
subject to grade4_combination {t in M+N+1..T+(F/2)}: y[4,t] >= z[t] + x[3,t-N-M] -1;
subject to one_grade {t in M+N+1..T+(F/2)}: sum{j in J} y[j,t] = 1;
subject to pour_in_one {t in N+M+1..T}: sum{q in Q,j in J} g[q,j,t] = 1;
subject to g_W {q in Q,j in J,t in N+M+1..T}: g[q,j,t] <= W[q,j,t];
subject to g_Y {j in J,t in N+M+1..T}: sum{q in Q}g[q,j,t] <= y[j,t];
subject to one_grade_in_silo {q in Q,t in N+M+1..T}: sum{j in J} W[q,j,t] <= 1;
subject to empty_for_change {q in Q,j in J,t in N+M..T-1}: W[q,j,t+1]-W[q,j,t] <= 1-sum{k in J}W[q,k,t];
subject to silo_max_capacity {q in Q,j in J,t in N+M+1..T}: S[q,j,t] <= Smax*W[q,j,t];
subject to silo_min_capacity {q in Q,j in J,t in N+M+1..T}: S[q,j,t] >= Smin*W[q,j,t];
subject to unloading_rate {q in Q,j in J,t in N+M+1..T}: G[q,j,t] <= uST*W[q,j,t];
subject to continuity {q in Q,j in J,t in N+M+1..T}: S[q,j,t] = S[q,j,t-1] + P*g[q,j,t] - G[q,j,t];
subject to safety_stock {j in J}: sum{q in Q} S[q,j,T] >= SS[j];
subject to unloading{q in Q, j in J,t in N+M+1..T}: G[q,j,t] = f[q,j,t] + h[q,j,t] + b[q,j,t] ;
subject to rates {q in Q,j in J,t in N+M+1..T}: (1/uST)*f[q,j,t] + (1/uBC)*h[q,j,t] + (1/uBB)*b[q,j,t]
<= 1;
subject to demand_silo_trucks {j in J,t in N+M+1..T}: dST[j,t] = sum{q in Q}f[q,j,t];
subject to demand_bulk_containers {j in J,t in N+M+1..T}: dBC[j,t] = sum {q in Q}h[q,j,t];
subject to max_sack_rate {t in N+M+1..T}:sum{q in Q,j in J}b[q,j,t] <= uBB;
subject to update_warehouse {j in J,t in N+M+1..T}: R[j,t] = R[j,t-1] + sum{q in Q}b[q,j,t]-
dBB[j,t];
subject to warehouse_capacity {t in N+M+1..T}: sum{j in J} R[j,t] <= Rmax;
subject to safety_stock_warehouse {j in J}: R[j,T] >= Rmin[j];
subject to initial_color {i in I,t in 1..N+M}: x[i,t] = X0[i,t];
subject to initial_viscosity: z[N+M] = Z0;

```

subject to initial_a {t in N+M-F+2..N+M}: a[t] = A0[t];
 subject to initial_silo {q in Q,j in J}: S[q,j,N+M] = S0[q,j];
 subject to initial_W {q in Q,j in J}: W[q,j,N+M] = W0[q,j];
 subject to initial_warehouse {j in J}: R[j,N+M] = R0[j];

Input data: 6MONTHS.txt

set I := 1 2 3;
 set J := 1 2 3 4;
 set Q := 1 2 3 4 5 6 7 8;
 set V := 1 2 3 4 5 6 7 8 9 10 11 12 13 14 15 16 17 18 19 20 21 22 23;

param T := 54;
 param M := 6;
 param N := 6;
 param P := 33.33;
 param uST := 224;
 param uBC := 69.2;
 param uBB := 40;
 param Smax := 430;
 param Smin := 1;
 param Rmax := 3500;
 param C := 1;
 param D := 1;
 param F := 6;
 param B := 1;
 param Z0 := 1;

param A0 :=
 8 0
 9 1
 10 0
 11 0
 12 0;

param X0:
 1 2 3 4 5 6 7 8 9 10 11 12 :=
 1 0 0 0 0 0 0 0 1 1 1 1 1
 2 0 0 0 0 0 0 1 0 0 0 0 0
 3 1 1 1 1 1 1 0 0 0 0 0 0;

param S0:
 1 2 3 4 :=
 1 400 0 0 0
 2 0 0 0 0
 3 400 0 0 0
 4 0 0 0 400
 5 0 0 0 0

```

6  0  0  0  400
7  0  0  0  350
8  0  150 0  0;

```

param SS:=

```

1  450
2  0
3  0
4  450;

```

param R0 :=

```

1  300
2  1100
3  0
4  500;

```

param Rmin :=

```

1  250
2  880
3  0
4  450;

```

param W0 :

```

  1 2 3 4 :=
1  1 0 0 0
2  0 0 0 0
3  1 0 0 0
4  0 0 0 1
5  0 0 0 0
6  0 0 0 1
7  0 0 0 1
8  0 1 0 0;

```

#demands of the first week

param dST:

```

  13  14  ...  53  54 :=
1  0  0  ...  0  0
2  0  0  ...  0  0
3  0  0  ...  0  0
4  0  25 ...  0  0;

```

param dBC:

```

  13  14  ...  53  54 :=
1  0  0  ...  0  0
2  0  0  ...  0  0
3  0  0  ...  0  0
4  0  0  ...  0  0;

```

param dBB:

	13	14	...	53	54 :=
1	0	38.5	...	0	0
2	0	0	...	0	0
3	0	0	...	0	0
4	30	30	...	0	0;

#demands of the other weeks

param dSTa:=

[1,*,*]:	13	14	...	53	54 :=
1	0	25	...	0	0
2	0	0	...	0	0
3	0	0	...	0	0
4	0	0	...	0	0;

[2,*,*]:	13	14	...	53	54 :=
1	0	0	...	0	0
2	0	0	...	0	0
3	0	0	...	0	0
4	0	0	...	0	0;

:

[23,*,*]:	13	14	...	53	54 :=
1	0	0	...	0	0
2	0	0	...	0	0
3	0	0	...	0	0
4	0	0	...	0	0;

param dBBa:=

[1,*,*]:	13	14	...	53	54 :=
1	0	50	...	0	0
2	50	50.1	...	0	0
3	0	0	...	0	0
4	0	50	...	37.6	0;

[2,*,*]:	13	14	...	53	54 :=
1	0	0	...	0	0
2	37.4	0	...	0	0
3	0	0	...	0	0
4	0	0	...	0	0;

:

[23,*,*]:	13	14	...	53	54 :=
1	0	50	...	0	0
2	0	0	...	0	29.7
3	0	0	...	0	0

```
4      0      0      ...      0      0;
```

```
param dSTa:=
```

```
[1,*,*]: 13      14      ...      53      54 :=
```

```
1      0      0      ...      0      0
```

```
2      0      0      ...      0      0
```

```
3      0      0      ...      0      0
```

```
4      0      0      ...      0      0;
```

```
[2,*,*]: 13      14      ...      53      54 :=
```

```
1      0      0      ...      0      0
```

```
2      0      0      ...      0      0
```

```
3      0      0      ...      0      0
```

```
4      0      23     ...      0      0;
```

```
:
```

```
[23,*,*]: 13      14      ...      53      54 :=
```

```
1      0      0      ...      0      0
```

```
2      0      0      ...      0      0
```

```
3      0      0      ...      0      0
```

```
4      0      0      ...      0      0;
```

AMPL code for solving repeatedly the MILP presented in Section 2.2, where in each repetition (week) the initial state is set equal to the final state of the previous repetition (week)

```
model VPI6months.txt;
```

```
data 6MONTHS.txt;
```

```
solve;
```

```
display {j in J, t in N+M+1..T+3} y[j,t] > test1.txt;
```

```
display {i in I, t in 1..T} x[i,t] > test2.txt;
```

```
display {t in N+M-4..T} a[t] > test3.txt;
```

```
display {t in N+M..T+3} z[t] > test4.txt;
```

```
display {q in Q, j in J} S[q,j,T] > test5.txt;
```

```
display {q in Q, j in J} W[q,j,T] > test6.txt;
```

```
display {j in J} R[j,T] > test7.txt;
```

```
display {q in Q, j in J, t in N+M+1..T} S[q,j,t] > test8.txt;
```

```
display {j in J, t in N+M+1..T} R[j,t] > test9.txt;
```

```
for {v in 1..23} {
```

```
let {q in Q, j in J} S0[q,j]:=S[q,j,T];
```

```
let {q in Q, j in J} W0[q,j]:=W[q,j,T];
```

```
let {j in J} R0[j]:=R[j,T];
```

```
let {i in I, tt in 1..12, t in T-11..T} X0[i,tt]:=x[i,t];
```

```
let Z0:=z[T];
```

```
let {t in T-4..T, tt in 8..12} A0[tt]:=a[t];
```

```
let {j in J, t in N+M+1..T} dST[j,t]:=dSTa[v,j,t];
```



```

let {j in J, t in N+M+1..T} dBC[j,t]:=dBCa[v,j,t];
let {j in J, t in N+M+1..T} dBB[j,t]:=dBBa[v,j,t];

solve;

display {j in J, t in N+M+1..T+3} y[j,t] > test1.txt;
display {i in I, t in 1..T} x[i,t] > test2.txt;
display {t in N+M-4..T} a[t] > test3.txt;
display {t in N+M..T+3} z[t] > test4.txt;
display {q in Q, j in J} S[q,j,T] > test5.txt;
display {q in Q, j in J} W[q,j,T] > test6.txt;
display {j in J} R[j,T] > test7.txt;
display {q in Q, j in J,t in N+M+1..T} S[q,j,t] > test8.txt;
display {j in J,t in N+M+1..T} R[j,t] > test9.txt;
}

```

Appendix D: Matlab codes for implementing the exact and heuristic solution procedures developed in Sections 3.2 and 3.3

In this appendix, we present the programming codes (in Matlab) for implementing the exact and heuristic solution procedures for problems with 4 and 5 grades. We also give the codes that we used to obtain the 2D graphs showing the optimal changeover presented in Section 2.3.

Codes for 4-grade problems

Program DP_4D_EXACT

Program that solves the SELSP problem for 4 grades using the exact solution procedure

Input

N = number of grades
X = FGI storage capacity
P_{MAX} = production rate
CC = changeover cost
CS = spillover cost
LS(1) = lost sales cost for grade 1
LS(2) = lost sales cost for grade 2
e = small positive number
DD = table of demand values for grades 1-4
PP = table of probabilities of demands for grades 1-4
DIM = dimension of tables DD and PP
n1 = special setup state
BIG = vey large number
X11 = special inventory level of grade 1
X21 = special inventory level of grade 2
X31 = special inventory level of grade 3
X41 = special inventory level of grade 4

Output

U(n,x1,x2,x3,x4) = optimal changeover policy for each setup state n and inventory level vector (x1, x2, x3, x4)
V(n,x1,x2,x3,x4) = optimal value function for each setup state n and inventory level vector (x1, x2, x3, x4)
W(n1,X11,X21,X31,X41) = optimal expected average cost
count = number of iterations (k_c) of the successive approximation method until convergence
tt = CPU time until convergence

Code

```
for n=1:4
  for x1=0:X
    for x2=0:X-x1
      for x3=0:X-x1-x2
        for x4=0:X-x1-x2-x3
          V(n,x1+1,x2+1,x3+1,x4+1)=0;
        end
      end
    end
  end
end
%MAIN LOOP
cont=1;
count=0;
tic
while cont==1
  count=count+1
  for n=1:4
    for x1=0:X
      for x2=0:X-x1
        for x3=0:X-x1-x2
          for x4=0:X-x1-x2-x3
            C=BIG;
            for m=max(1,n-1):min(n+1,N)
              if m~=n
                C1=CC;
              else
                C1=0;
              end
              PROD=PMAX;
              if x1+x2+x3+x4+PMAX>X
                PROD=X-x1-x2-x3-x4;
                C1=C1+CS*(PMAX-PROD);
              end
              xx=[x1,x2,x3,x4];
              for d1=1:DIM(1)
                for d2=1:DIM(2)
                  for d3=1:DIM(3)
                    for d4=1:DIM(4)
                      dd(1)=DD(1,d1);
                      dd(2)=DD(2,d2);
                      dd(3)=DD(3,d3);
                      dd(4)=DD(4,d4);
                      for j=1:4
                        if j==n
                          p=PROD;
                        end
                      end
                    end
                  end
                end
              end
            end
          end
        end
      end
    end
  end
  cont=cont+1;
  count=count+1;
end
toc
```

```

else
    p=0;
end
if xx(j)+p>dd(j)
    y(j)=xx(j)+p-dd(j);
else
    y(j)=0;
    C1=C1+LS*(dd(j)-xx(j)-
p)*PP(1,d1)*PP(2,d2)*PP(3,d3)*PP(4,d4);
end
end
C1=C1+V(m,y(1)+1,y(2)+1,y(3)+1,y(4)+1)*PP(1,d1)*PP(2,d2)*P
P(3,d3)*PP(4,d4);
end
end
end
end
end
if C1<C
    C=C1;
    W(n,x1+1,x2+1,x3+1,x4+1)=C;
    U(n,x1+1,x2+1,x3+1,x4+1)=m;
end
end
end
end
end
end
end
VMIN=BIG;
VMAX=-BIG;
for n=1:4
    for x1=1:X+1
        for x2=1:X+2-x1
            for x3=1:X+3-x1-x2
                for x4=1:X+4-x1-x2-x3
                    temp=V(n,x1,x2,x3,x4);
                    V(n,x1,x2,x3,x4)=W(n,x1,x2,x3,x4)-W(n1,X11,X21,X31,X41);
                    VDIFF=V(n,x1,x2,x3,x4)-temp;
                    if VDIFF<VMIN
                        VMIN=VDIFF;
                    end
                    if VDIFF>VMAX
                        VMAX=VDIFF;
                    end
                end
            end
        end
    end
end
end
end
end

```

```

end
if abs(VMAX-VMIN)>e*W(n1,X11,X21,X31,X41)
    cont=1;
else
    cont=0;
end
end
end
tt=toc

```

Function GEN_U_SUB

Function that finds the optimal changeover policies of the 3-grade sub-problems

Input

N , X , P_{MAX} , CC , CS , LS , e , DD , PP , DIM

Output

$UH(i, n, x1, x2, x3)$ = heuristic changeover policy for each setup state n and inventory level vector $(x1, x2, x3)$, for sub-problem i

countH = number of iterations (k_c) of the successive approximation method until convergence for sub-problem i

ttH(i) = CPU times until convergence for sub-problem i

Code

```

for i=2:N-1
    [DEML,PL,DL]=CONVOLVENDem(i-1,DD(1:i-1,:),PP(1:i-1,:),DIM(1:i-1));
    DEMM= DD(i,:);
    PM= PP(i,:);
    DM=DIM(i);
    [DEM,PR,DR]=CONVOLVENDem(N-i,DD(i+1:N,:),PP(i+1:N,:),DIM(i+1:N));
    [U,W,count,tt]=solve3dem(X,PMAX,DEML,DEMM,DEM,PL,PM,PR,DL,DM,DR,CC,CS,LS,
    e);
    UH(i, :, :, :)=U;
    countH(i) = count;
    ttH(i)= tt;
end

```

Function CONVOLVENDem

Function that finds the convolution of demands of N products

Input

NUM = number of products (N)

DDSUB = table of demand values for the N products

PPSUB = table of probabilities of the demand values of the N products

DIMSUB = dimension of the table of demand values

Output

DOLD = table of the summation of the demand values of the N products
 POLD = table of probabilities of the summation of the demand values of the N products
 DIMOLD = dimension of DOLD

Code

```
function [DOLD,POLD,DIMOLD]=CONVOLVENdem(NUM,DDSUB,PPSUB,DIMSUB)
if NUM==1
    DOLD=DDSUB;
    POLD=PPSUB;
    DIMOLD=DIMSUB;
else
    DOLD=DDSUB(1,:);
    POLD=PPSUB(1,:);
    DIMOLD=DIMSUB(1);
    for i=2:NUM
        [DNEW,PNEW,DIMNEW]=CONVOLVE2dem(DOLD,POLD,DIMOLD,DDSUB(i,:),PPSUB
        B(i,:),DIMSUB(i));
        DOLD=DNEW;
        POLD=PNEW;
        DIMOLD=DIMNEW;
    end
end
```

Function CONVOLVE2dem

Function that finds the convolution of demands of 2 products

Input

D1 = table of demand values of 1st product
 P1 = table of probabilities of demand values of 1st product
 DIM1 = dimension of table of demand values of 1st product
 D2 = table of demand values of 2nd product
 P2 = table of probabilities of demand values of 2nd product
 DIM2 = dimension of table of demand values of 2nd product

Output

DSUM = table of the summation of the demand values of the 2 products
 PSUM = table of probabilities of the summation of the demand values of the 2 products
 DIMSUM = dimension of DSUM

Code

```
function [DSUM,PSUM,DIMSUM]=CONVOLVE2dem(D1,P1,DIM1,D2,P2,DIM2)
count=1;
for i=1:DIM1
    for j=1:DIM2
        Dtot(count) = D1(i) + D2(j);
        Ptot(count) = P1(i)*P2(j);
        count = count + 1;
    end
end
```

```

    end
end
[Dfin,i1]=sort(Dtot);
Pfin=Ptot(i1);
DSUM(1) = Dfin(1);
PSUM(1) = Pfin(1);
DIMSUM = 1;
for i=2:DIM1*DIM2
    if Dfin(i) ~= DSUM(DIMSUM)
        DIMSUM = DIMSUM + 1;
        DSUM(DIMSUM) = Dfin(i);
        PSUM(DIMSUM) = Pfin(i);
    else
        PSUM(DIMSUM) = PSUM(DIMSUM) + Pfin(i);
    end
end
end

```

Function solve3dem

Function that finds the optimal changeover policy for a 3-grade problem

Input

X, PMAX, DEM1, DEM2, DEM3, P1, P2, P3, D1, D2, D3, CC, CS, LS, e, BIG, n1, X11, X21, X31, N

Output

U(n,x1,x2,x3,x4) = optimal changeover policy for each setup state n and inventory level vector (x1, x2, x3)

V(n,x1,x2,x3,x4) = optimal value function for each setup state n and inventory level vector (x1, x2, x3, x4)

W(n1,X11,X21,X31) = optimal expected average cost

count = number of iterations (k_c) of the successive approximation method until convergence

tt = CPU time until convergence

Code

Function [U,W,count1,tt]=solve3dem(X,PMAX,DEM1,DEM2,DEM3,P1,P2,P3,D1,D2,D3,CC,CS,LS,e)

```

BIG=100000;
n1=1;
X11=1;
X21=1;
X31=1;
N = 3;
for n=1:3
    for x1=0:X
        for x2=0:X-x1
            for x3=0:X-x1-x2

```



```

        V(n,x1+1,x2+1,x3+1)=0;
    end
end
end
end

%MAIN LOOP
cont=1;
count1=0;
tic
while cont==1
    % while count1<=5
    count1=count1+1
    for n=1:3
        for x1=0:X
            for x2=0:X-x1
                for x3=0:X-x1-x2
                    C=BIG;
                    for m=max(1,n-1):min(n+1,N)
                        if m~=n
                            C1=CC;
                        else
                            C1=0;
                        end
                        PROD=PMAX;
                        if x1+x2+x3+PMAX>X
                            PROD=X-x1-x2-x3;
                            C1=C1+CS*(PMAX-PROD);
                        end
                        xx(1)=x1;
                        xx(2)=x2;
                        xx(3)=x3;
                        for d1=0:D1-1
                            for d2=0:D2-1
                                for d3=0:D3-1
                                    dd(1)=DEM1(d1+1);
                                    dd(2)=DEM2(d2+1);
                                    dd(3)=DEM3(d3+1);
                                    for j=1:3
                                        if j==n
                                            p=PROD;
                                        else
                                            p=0;
                                        end
                                        if xx(j)+p>dd(j)
                                            y(j)=xx(j)+p-dd(j);
                                        else
                                            y(j)=0;
                                        end
                                    end
                                end
                            end
                        end
                    end
                end
            end
        end
    end
end

```

```

                C1=C1+LS*(dd(j)-xx(j)-p)*P1(d1+1)*P2(d2+1)*P3(d3+1);
            end
        end
        C1=C1+V(m,y(1)+1,y(2)+1,y(3)+1)*P1(d1+1)*P2(d2+1)*P3(d3+1);
    end
end
end
end
end
if C1<C
    C=C1;
    W(n,x1+1,x2+1,x3+1)=C;
    U(n,x1+1,x2+1,x3+1)=m;
end
end
end
end
end
end
VMIN=BIG;
VMAX=-BIG;
for n=1:3
    for x1=1:X+1
        for x2=1:X+2-x1
            for x3=1:X+3-x1-x2
                Y(n,x1,x2,x3)=V(n,x1,x2,x3);
                V(n,x1,x2,x3)=W(n,x1,x2,x3)-W(n1,X11,X21,X31);
                VDIFF=V(n,x1,x2,x3)-Y(n,x1,x2,x3);
                if VDIFF<VMIN
                    VMIN=VDIFF;
                end
                if VDIFF>VMAX
                    VMAX=VDIFF;
                end
            end
        end
    end
end
end
if abs(VMAX-VMIN)>e*W(n1,X11,X21,X31)
    cont=1;
else
    cont=0;
end
end
end
toc
tt=toc;

```

Program DP_4D_HEUR:

Program that solves the 4-grade problem using the heuristic solution procedure for different values of the coefficient α used in equation (3.5)

Input

aa = coefficient α used in equation (3.5)
astep = step by which coefficient α is incremented
counta = number of different values of coefficient α tested
ED = expected demand vector (equal to $\text{sum}(\text{DD}.*\text{PP})$)

Output

bbb = minimum expected average cost equal to $W(n', x_i')$
 $W(n1, X11, X21, X31, X41)$ = expected average cost obtained by the heuristic solution procedure
count = number of iterations (k_c) of the successive approximation method until convergence
tt = CPU time until convergence

Code

```
while aa <= 1
    counta=counta+1;
    [UFINAL]=GEN_U_HEUR_4D(UH,N,X,aa,ED);
    [aaa,bbb,ccc,W,count,tt]=DP_4D_EXACT_NoOPT(X,PMAX,UFINAL,DD,PP,DIM,CC,CS,LS,
        e);
    ResultsTBL(counta,:)= [bbb,count,tt];
    aa = aa + astep;
end
```

Function GEN_U_HEUR_4D

Function that constructs the heuristic changeover policy of the 4-grade problem using parts of the optimal changeover policies of the 3-grade sub-problems

Input

UH, N, X, aa, ED

Output

UFINAL = heuristic changeover policy of original 4-grade problem

Code

```
function [UFINAL]=GEN_U_HEUR_4D(UH, N, X, aa, ED)

for x1=0:X
    for x2=0:X-x1
        for x3=0:X-x1-x2
            for x4=0:X-x1-x2-x3
                xvec=[x1,x2,x3,x4];
                UFINAL(1,x1+1,x2+1,x3+1,x4+1)=UH(2,1,x1+1,x2+1,GEN_X_SUB(xvec(3:4),ED(3:4),aa)+1);
                UFINAL(2,x1+1,x2+1,x3+1,x4+1)=UH(2,2,x1+1,x2+1,GEN_X_SUB(xvec(3:4),ED(3:4),aa)+1);
            end
        end
    end
end
```

```

        UFINAL(3,x1+1,x2+1,x3+1,x4+1)=UH(3,2,GEN_X_SUB(xvec(1:2),ED(1:2),aa)+1,x3
            +1,x4+1)+1;
        UFINAL(4,x1+1,x2+1,x3+1,x4+1)=UH(3,3,GEN_X_SUB(xvec(1:2),ED(1:2),aa)+1,x3
            +1,x4+1)+1;
    end
end
end
end

```

Function GEN_X_SUB

Function that calculates the inventory level of the aggregate product according to equation (3.5)

Input

x, ED, aa

Output

xnew = inventory level of the aggregate product

Code

```

function [xnew]=GEN_X_SUB(x,ED,aa)
LS=sum(max(ED-x,0));
xnew=round((LS==0)*sum(x)+(LS>0)*(aa*(sum(ED)-LS)+(1-aa)*sum(x)));

```

Function DP_4D_EXACT_NoOPT

Function that evaluates the heuristic changeover policy of the 4-grade problem

Input

X, PMAX, U, DD, PP, CC, CS, LS, e, BIG, n1, X11, X21, X31, X41, DIM

Output

aaa = (VMAX-VMIN)

bbb = W(n1,X11,X21,X31,X41)

ccc = e* W(n1,X11,X21,X31,X41)

W(n,x1,x2,x3,x4) = optimal value function mapping for each setup state n and inventory level vector (x1, x2, x3, x4), given by equation (3.7)

count = number of iterations (k_c) of the successive approximation method until convergence

tt = CPU time until convergence

Code

```

function
[aaa,bbb,ccc,W,count,tt]=DP_4D_EXACT_NoOPT(X,PMAX,U,DD,PP,DIM,CC,CS,LS,e);
for n=1:4
    for x1=0:X
        for x2=0:X-x1
            for x3=0:X-x1-x2
                for x4=0:X-x1-x2-x3

```

```

        V(n,x1+1,x2+1,x3+1,x4+1)=0;
    end
end
end
end
end

%MAIN LOOP
cont=1;
count=0;
tic
while cont==1
    % while count==0
    count=count+1
    for n=1:4
        for x1=0:X
            for x2=0:X-x1
                for x3=0:X-x1-x2
                    for x4=0:X-x1-x2-x3
                        m=U(n,x1+1,x2+1,x3+1,x4+1);
                        if m~=n
                            C1=CC;
                        else
                            C1=0;
                        end
                        PROD=PMAX;
                        if x1+x2+x3+x4+PMAX>X
                            PROD=X-x1-x2-x3-x4;
                            C1=C1+CS*(PMAX-PROD);
                        end
                        xx=[x1,x2,x3,x4];
                        for d1=1:DIM(1)
                            for d2=1:DIM(2)
                                for d3=1:DIM(3)
                                    for d4=1:DIM(4)
                                        dd(1)=DD(1,d1);
                                        dd(2)=DD(2,d2);
                                        dd(3)=DD(3,d3);
                                        dd(4)=DD(4,d4);
                                        for j=1:4
                                            if j==n
                                                p=PROD;
                                            else
                                                p=0;
                                            end
                                            if xx(j)+p>dd(j)
                                                y(j)=xx(j)+p-dd(j);
                                            else

```

```

        y(j)=0;
        C1=C1+LS*(dd(j)-xx(j)-p)*PP(1,d1)*PP(2,d2)*PP(3,d3)*
        PP(4,d4);
    end
end
C1=C1+V(m,y(1)+1,y(2)+1,y(3)+1,y(4)+1)*PP(1,d1)*PP(2,d2)*PP(3,
d3)*PP(4,d4);
end
end
end
end
end
W(n,x1+1,x2+1,x3+1,x4+1)=C1;
end
end
end
end
end
VMIN=BIG;
VMAX=-BIG;
for n=1:4
    for x1=1:X+1
        for x2=1:X+2-x1
            for x3=1:X+3-x1-x2
                for x4=1:X+4-x1-x2-x3
                    temp=V(n,x1,x2,x3,x4);
                    V(n,x1,x2,x3,x4)=W(n,x1,x2,x3,x4)-W(n1,X11,X21,X31,X41);
                    VDIFF=V(n,x1,x2,x3,x4)-temp;
                    if VDIFF<VMIN
                        VMIN=VDIFF;
                    end
                    if VDIFF>VMAX
                        VMAX=VDIFF;
                    end
                end
            end
        end
    end
end
end
if abs(VMAX-VMIN)>e*W(n1,X11,X21,X31,X41)
    cont=1;
else
    cont=0;
end
end
end
tt=toc

```

Program SIM_4D_EXACT

Program that evaluates the optimal changeover policy of the 4-grade problem using simulation

Input

N, X, PMAX, CC, CS, LS, e, DD, PP, DIM,U

Output

CTOT = total cost

tsim = simulation time

Code

```
load('DP_4D_1_EXACT.mat','U');
load('DATA_4D_1.mat');
R = 60;
T = 100000;
Ccum=0;
Csqcum=0;
tcum=0;
CCI=0;
for i=1:R
    [CTOT,tsim]=SIM_4D(X,PMAX,U,DD,PP,DIM,CC,CS,LS,N,T);
    CTOTMAT(i)=CTOT;
    TSIMMAT(i)=tsim;
    Ccum=Ccum+CTOT;
    Csqcum = Csqcum + CTOT^2;
    tcum=tcum+tsim;
end
```

Program SIM_4D_HEUR

Program that evaluates the heuristic changeover policy of the 4-grade problem for different values of the coefficient α used in equation (3.5), using simulation

Input

X, PMAX, UFINAL, DD, PP, DIM, CC, CS, LS, N, astep, aa, counta, ED

T = total number of counts in simulation

R = demand width

U_SUB = sub-problem policies

Output

Caver = average total cost

CConfInter = confidence interval of average total cost

taver = average total CPU time until a solution is reached through simulation

Code

```
while aa <=1
    counta=counta+1;
    [UFINAL]=GEN_U_HEUR_4D(UH,N,X,aa,ED);
    Ccum=0;
```

```

Csqcum=0;
tcum=0;
CCI=0;
for i=1:R
    [CTOT,tsim]=SIM_4D(X,PMAX,UFINAL,DD,PP,DIM,CC,CS,LS,N,T);
    CTOTMAT(counta,i)=CTOT;
    TSIMMAT(counta,i)=tsim;
    Ccum=Ccum+CTOT;
    Csqcum = Csqcum + CTOT^2;
    tcum=tcum+tsim;
end
Caver = Ccum/R
CConfInter = 2*sqrt((Csqcum - R*Caver^2)/(R*(R-1)));
taver = tcum/R;
ResultsTBL(counta,:)=[aa,Caver,CConfInter,taver];
aa = aa + astep;
end

```

Function SIM_4D

Function that performs a single simulation run of the 4-grades problem for a given changeover policy U

Input

X, PMAX, U, DD, PP, DIM, CC, CS, LS, N, T

Output

CTOT
tsim

Code

```

function [CTOT,tsim]=SIM_4D(X,PMAX,U,DD,PP,DIM,CC,CS,LS,N,T);
CP = [zeros(N,1) cumsum(PP,2)];
C1 = 0;
C2 = 0;
CC3(1:N) = 0;
CTOT = 0;
% Initial state
n = 2;
x(1:N) = 2;
A = [n x];
tic
for t=1:T
    m = U(n,x(1)+1,x(2)+1,x(3)+1,x(4)+1);
    C1 = C1 + CC*(m~=n);
    PROD = min(PMAX, X - sum(x));
    C2 = C2 + CS*(PMAX - PROD);
    TT=sum(bsxfun(@gt,rand(N,1),CP),2);

```



```

for i=1:N
    D(i)=DD(i,TT(i));
end
y = x + PROD*([1:N]==n) - D;
CC3 = CC3 - LS*bsxfun(@times,y<0,y);
x = bsxfun(@times,y > 0, y);
n = m;
end
CTOT = (C1 + C2 + sum(CC3))/t;
tsim=toc;

```

Codes for 5-grade problems

All the codes for solving 5-grade problems are similar to those for solving the 4-grade problem, and are therefore omitted. The only code, which slightly differs is the following:

Function GEN_U_HEUR_5D

Function that constructs the heuristic changeover policy of the 5-grade problem using parts of the optimal changeover policies of the 3-grade sub-problems

Input

UH, N, X , aa , ED

Output

UFINAL

Code

```

function [UFINAL]=GEN_U_HEUR_5D(UH, N, X, aa, ED)
for x1=0:X
    for x2=0:X-x1
        for x3=0:X-x1-x2
            for x4=0:X-x1-x2-x3
                for x5=0:X-x1-x2-x3-x4
                    xvec=[x1,x2,x3,x4,x5];
                    UFINAL(1,x1+1,x2+1,x3+1,x4+1,x5+1)=UH(2,1,x1+1,x2+1,GEN_X_SUB(xvec(3:5),ED(3:5),aa)+1);
                    UFINAL(2,x1+1,x2+1,x3+1,x4+1,x5+1)=UH(2,2,x1+1,x2+1,GEN_X_SUB(xvec(3:5),ED(3:5),aa)+1);
                    UFINAL(3,x1+1,x2+1,x3+1,x4+1,x5+1)=UH(3,2,GEN_X_SUB(xvec(1:2),ED(1:2),aa)+1,x3+1,GEN_X_SUB(xvec(4:5),ED(4:5),aa)+1)+1;
                    UFINAL(4,x1+1,x2+1,x3+1,x4+1,x5+1)=UH(4,2,GEN_X_SUB(xvec(1:3),ED(1:3),aa)+1,x4+1,x5+1)+5-3;
                    UFINAL(5,x1+1,x2+1,x3+1,x4+1,x5+1)=UH(4,3,GEN_X_SUB(xvec(1:3),ED(1:3),aa)+1,x4+1,x5+1)+5-3;
                end
            end
        end
    end
end

```

```
    end
  end
end
```

Code for drawing the optimal changeover policy graphs

Program GRAPHK

Program that draws in 2D the optimal changeover policy of a 3-grade problem for a given value k of the inventory level of grade 3

Input

U=changeover policy

Output

Graphs

Code

```
k=input('give value for k, k=')
for i=1:X-k+2
    for j=1:X-k+3-i
        tst1(j,i)=U(1,i,j,k+1);
        tst2(j,i)=U(2,i,j,k+1);
        tst3(j,i)=U(3,i,j,k+1);
        for ia=1:3
            for ja=1:3
                for ka=1:3
                    if tst1(j,i)==ia & tst2(j,i)==ja & tst3(j,i)==ka
                        tst4(j,i)=ia*9+ja*3+ka-12;
                    end
                end
            end
        end
    end
end
end
end
end
end

figure(1);hold on;
title('graphU (n=1)')
xlabel('X_1')
ylabel('X_2')
surf(tst1)

figure(2);hold on;
title('graphU (n=2)')
xlabel('X_1')
ylabel('X_2')
surf(tst2)
```

```
figure(3);hold on;
title('graphU (n=3)')
xlabel('X_1')
ylabel('X_2')
surf(tst3)
```

```
figure(4);hold on;
title('graphU')
xlabel('X_1')
ylabel('X_2')
surf(tst4)
```

Code for finding optimal safety stocks

Program optimum_x1_x2

Program that finds the optimal stock levels to be used in the procedure outlined in Section 2.3.1.

Input

U , X

Output

Optimal stock levels of x_1 and x_2 that minimizes the differential cost $V(n, x_i)$

Code

```
for n=1:2
    VMIN=100000;
    for x1=0:X
        for x2=0:X-x1
            if V(n,x1+1,x2+1)<VMIN
                VMIN=V(n,x1+1,x2+1);
                K(n,,:,)= [n,VMIN,x1+1 x2+1];
            end
        end
    end
end
```

Appendix E: Results of the heuristic policy evaluated in Section 3.4.3 for different values of parameter α

Table A-3. Complete set of results of the heuristic policy evaluated using the value iteration method for the 4-grade example presented in Section 3.4.3

Case	Demand pattern	CPU (sec)	a	k_c	$J^h(a)$
1	<i>B,D,D,B</i>	44308	0	70	1.3891
		42126	0.1	69	1.3751
		25188	0.2	68	1.3867
		31836	0.3	60	1.3642
		30887	0.4	57	1.3171
		29465	0.5	56	1.2904
		19948	0.6	55	1.2566
		69925	0.7	130	1.2442
2	<i>D,D,B,B</i>	35192	0	146	1.2367
		31127	0.1	156	1.2305
		33289	0.2	166	1.2285
		34647	0.3	172	1.2269
		34960	0.4	175	1.2263
		35096	0.5	175	1.2253
		34571	0.6	173	1.2267
		33754	0.7	169	1.2271
3	<i>D,B,D,B</i>	40549	0	203	1.2312
		71143	0.1	355	1.2328
		76778	0.2	215	1.3262
		126720	0.3	211	1.331
		120180	0.4	206	1.3291
		74241	0.5	202	1.3314
		103620	0.6	195	1.3376
		67907	0.7	191	1.3388
4	<i>D,B,B,D</i>	60305	0	115	1.3141
		41770	0.1	118	1.3139
		88204	0.2	118	1.3142
		41296	0.3	117	1.3156
		61512	0.4	117	1.3159
		69141	0.5	116	1.3164
		71163	0.6	115	1.3168
		40356	0.7	115	1.3172

Table A-4. Complete set of results of the heuristic policy evaluated using simulation for the 4-grade example presented in Section 3.4.3

Case	Demand pattern	CPU (sec)	a	$J^h(a)$ (95% c.i.)
1	<i>B,D,D,B</i>	12.617	0	1.3359±0.0014
		12.593	0.1	1.3206±0.0019
		12.788	0.2	1.3272±0.0019
		12.639	0.3	1.3253±0.0021
		12.797	0.4	1.3303±0.0017
		12.835	0.5	1.3321±0.0017
		13.096	0.6	1.3367±0.0016
		12.832	0.7	1.3384±0.0021
		12.632	0.8	1.3385±0.0018
		12.582	0.9	1.3421±0.0016
		12.443	1	1.3416±0.0021
2	<i>D,D,B,B</i>	11.182	0	1.3140±0.0021
		11.117	0.1	1.3135±0.0018
		11.047	0.2	1.3144±0.0013
		11.031	0.3	1.3157±0.0016
		11.033	0.4	1.3159±0.0020
		11.031	0.5	1.3170±0.0017
		11.030	0.6	1.3172±0.0018
		11.026	0.7	1.3179±0.0018
		11.032	0.8	1.3183±0.0020
		11.038	0.9	1.3174±0.0017
		11.035	1	1.3181±0.0021
3	<i>D,B,D,B</i>	6.475	0	1.3898±0.0022
		6.482	0.1	1.3761±0.0021
		6.484	0.2	1.3867±0.0024
		6.547	0.3	1.3599±0.0022
		6.475	0.4	1.3178±0.0014
		6.503	0.5	1.2894±0.0021
		6.529	0.6	1.2564±0.0015
		6.484	0.7	1.2445±0.0019
		6.476	0.8	1.2719±0.0153
		6.489	0.9	2.7741±0.5626
		6.483	1	2.8880±0.5244
4	<i>D,B,B,D</i>	8.6171	0	1.2356±0.0011
		8.5913	0.1	1.2308±0.0010
		8.6226	0.2	1.2288±0.0011
		8.5926	0.3	1.2265±0.0011
		8.4072	0.4	1.2263±0.0010
		8.3407	0.5	1.2253±0.0011

8.3839	0.6	1.2276±0.0010
8.3947	0.7	1.2268±0.0010
8.3795	0.8	1.2305±0.0010
8.3666	0.9	1.2328±0.0009
8.3711	1	1.3153±0.0296

Table A-5. Complete set of results of the heuristic policy evaluated using simulation for the 5-grade example presented in Section 3.4.3

Case	Demand pattern	CPU (sec)	a	$J^h(a)$ (95% c.i.)
		3.8711	0	3.1001±0.0016
		3.8590	0.1	3.0355±0.0016
		3.8558	0.2	3.0800±0.0020
		3.8533	0.3	3.1530±0.0020
		3.8600	0.4	3.2087±0.0025
1	A,C,D,C,A	3.8538	0.5	3.3301±0.0025
		3.8432	0.6	3.6575±0.0029
		3.8422	0.7	5.4469±0.0036
		3.8425	0.8	5.4512±0.0033
		3.8420	0.9	5.4227±0.0034
		3.8428	1	5.4595±0.0031
		3.8840	0	3.4926±0.0017
		3.8500	0.1	3.4512±0.0015
		3.8622	0.2	3.4644±0.0020
		3.8242	0.3	3.4641±0.0018
		3.8852	0.4	3.4578±0.0016
2	D,C,C,A,A	3.8335	0.5	3.4852±0.0019
		3.8244	0.6	3.5318±0.0030
		4.1222	0.7	3.8665±0.0128
		4.0414	0.8	5.6717±0.0291
		3.8489	0.9	8.2742±0.0027
		3.8103	1	8.2735±0.0029
		3.6524	0	3.8759±0.0020
		3.1777	0.1	3.9863±0.0018
		2.7754	0.2	4.0763±0.0028
		2.2716	0.3	4.2347±0.0027
		2.2910	0.4	4.3579±0.0031
3	D,C,A,A,C	2.2859	0.5	4.5680±0.0045
		2.3008	0.6	4.8012±0.0049
		2.2945	0.7	5.2577±0.0058
		2.2896	0.8	7.3457±0.0055
		2.2916	0.9	10.3628±0.0030
		2.2757	1	10.3631±0.0026
4	D,A,C,A,C	3.7605	0	3.9348±0.0020

3.7307	0.1	3.9473±0.0023
3.7384	0.2	3.9805±0.0024
3.7392	0.3	4.0324±0.0022
3.7412	0.4	4.1035±0.0031
3.7335	0.5	4.2739±0.0046
3.7333	0.6	6.2144±0.0294
3.7319	0.7	8.2519±0.0041
3.7332	0.8	10.0704±0.0028
3.7339	0.9	10.3622±0.0023
3.7337	1	10.3614±0.0027
